

1971 SUPPLEMENT **ELECTRONICS FOR**

MEASUREMENT
ANALYSIS
COMPUTATION

Acoustical Instruments
Automatic Test Systems
Calculators and Peripherals
Communications Test Equipment
Computers and Peripherals
Data Acquisition Systems
DC Power Supplies
Digital Analyzers
Electronic Counters
Electro-Optical Instruments
Frequency and Time Standards
Graphic Recorders
Magnetic Recorders
Meters, Multifunction
Microwave Test Equipment
Network Analyzers
Oscilloscope Systems
Signal Analyzers
Signal Generators
Signal Sources
Spectrum Analyzers



About your Hewlett-Packard Supplement

Your 1971 Catalog Supplement describes the new products and accessories which have recently been introduced by the Hewlett-Packard Company. While it is a single reference for new products, it is also fully indexed for use as a paired volume with the 1970 Hewlett-Packard Catalog.

As indicated by the synopsis to the right, Hewlett-Packard provides equipment and accessories for the many technical phases of Science, Industry and Education.

How to use your 1971 Supplement

The 1971 Supplement contains both an Alphabetical Index and a Model Number Index to help you locate product information.

Each Index contains two types of page numbers:

- The blue numbers in bold-face type refer to the pages contained in this Supplement.
- The black numbers in light-face type refer to pages in the 1970 Catalog.

The Alphabetical Index begins on page 4 of the Supplement. The Model Number Index, which also contains basic prices, current at time of printing, begins on page 15.

For assistance, call your nearest Hewlett-Packard Sales and Service office. Their addresses and telephone numbers are listed on pages 2 and 3.

GENERAL PURPOSE

Amplifiers	Oscilloscopes
Digital Voltmeters	Q Meters
Electronic Counters	Signal Generators
Function Generators	Signal Sources

SCIENTIFIC

Fourier Analyzers	Radiant Flux Detectors
Laser Interferometers	Radiant Flux Meters
Quartz Thermometers	Spectrum Analyzers

COMPUTATION

Analog to Digital Converters	Digital Tape Units
Computer Peripherals	Logic Clips
Coupler/Controller	Paper Tape Readers

SYSTEMS

Disc Operating Systems	Phase-Locked
Multiprogrammer Systems	Microwave Source
Automatic Network	System
Analyzer Systems	

MICROWAVE

Digital Markers	S-Parameter Test Sets
Digital Power Meters	Spectrum Analyzers
Programmable Attenuators	Sweep Oscillators
Programmable Microwave Sources	

COMMUNICATIONS

Spectrum Analyzers	Telephone Oscillators
Psophometer	

See also 1970 HP Catalog

GENERAL INFORMATION



HOW TO ORDER



Although Hewlett-Packard products are manufactured throughout the United States and other parts of the world, the Hewlett-Packard field office or distributor in your area is best equipped to handle all your needs concerning products described in this catalog, and for parts and service on Hewlett-Packard products you already own. The worldwide listing of field offices, representatives, and distributors, current at the time of publication, is found on pages 2 and 3.

Order by model number

Technical assistance in selecting equipment and preparing orders is available, without charge, from field engineers at all sales offices. When you place your order, please specify the catalog model number as well as the name of the product desired. Whenever you want special options or features, such as special color or non-standard power line voltage, ask your Hewlett-Packard field engineer about availability of these options, then, to prevent misunderstanding, include significant specifications and specific instructions in your order.

FOR CUSTOMERS IN USA

Where to send your order

Your order should be made out to the Hewlett-Packard Company and sent to the Hewlett-Packard office nearest you (see page 2). Each field office has special communication channels to Hewlett-Packard manufacturing facilities to assure prompt and efficient handling of your order. (For Delcon products, please see pages 423 and 424 in the 1970 Measurement, Analysis Computation Catalog).

Shipping methods

Shipments to destinations in the USA are made directly from local factories or warehouses. Unless specifically requested otherwise, express or truck transportation is used, whichever is less expensive and most serviceable to you. Small items are sent parcel post. If fast delivery is needed, we gladly ship by air freight, air express, or air parcel post, when

Many Hewlett-Packard instruments are supplied in cabinets along with easily attached hardware for direct mounting in standard 19-inch equipment racks. Others are available in two configurations: one a cabinet for bench use and the other with a 19-inch panel for rack mounting. Catalog listings indicate the availability of cabinet or rack mounting arrangements.

Pricing policy and delivery information

Prices in this catalog are net prices that prevailed at the time the catalog was approved for printing and are F.O.B. USA factory or warehouse, except as indicated. Prices prevailing at the time the order is received will apply. Please consult your nearest field sales office to confirm prices at your location and to obtain current delivery information. Although the illustrations and product information in this catalog were current at the time the catalog was approved for printing, Hewlett-Packard in a continuing effort to offer the finest equipment available, reserves the right to change specifications, designs, models or prices without notice.

specified on your order, at prevailing rates. In many parts of the USA, a consolidated air freight service provides the speed of air transport at surface rates. Ask your field engineer for details.

Terms in the USA

Terms are net 30 days from invoice date. Extended payment terms to a maximum of 120 days are available on approved credit for a service charge. Your local Hewlett-Packard sales office has the details. Unless credit with Hewlett-Packard has already been established, shipments will be made C.O.D. or on receipt of cash in advance.

Quotations

Upon request, quotations including destination prices, will be furnished to you by your local Hewlett-Packard sales office.

FOR CUSTOMERS OUTSIDE THE USA

Where to send your order

In many countries, your order can be placed directly with your local Hewlett-Packard distributor or representative. If there is none as yet in your area, your order should be placed directly with the office indicated for your part of the world.

Shipping methods

Shipments to customers outside the USA or Western Europe are made from the appropriate Hewlett-Packard facility by either surface or air, as requested. Sea shipments usually require commercial export packaging at a nominal extra charge.

Terms

Terms for orders from countries outside the United States of America which are placed with the Hewlett-Packard Company, Hewlett-Packard S.A., or Hewlett-Packard Inter-Americas, are irrevocable letter of credit or cash in advance, unless other terms have been arranged previously. Terms for orders placed with authorized Hewlett-Packard distributors are mutually determined between customer and distributor.

Quotations and pro forma invoices

FAS, CIF, C&F, etc. quotations or pro forma invoices, as well as exportation and importation assistance, are available on request from local authorized Hewlett-Packard sales offices or representatives.

HP Computer Museum
www.hpmuseum.net

For research and education purposes only.

SALES & SERVICE OFFICES



UNITED STATES, CANADA CENTRAL AND SOUTH AMERICA

UNITED STATES

ALABAMA
P.O. Box 4207
2003 Byrd Spring Road S.W.
Huntsville 35802
Tel: (205) 881-4591
TWX: 810-726-2204

ARIZONA
2335 E. Magnolia St.
Phoenix 85034
Tel: (602) 252-5061
TWX: 910-951-1330
5737 East Broadway
Tucson 85716
Tel: (602) 298-2313
TWX: 910-952-1162

CALIFORNIA
1430 East Orangehorpe Ave.
Fullerton 92631
Tel: (714) 870-1000
3939 Lankershim Boulevard
North Hollywood 91604
Tel: (213) 877-1282
TWX: 910-499-2170

1101 Embarcadero Road
Palo Alto 94303
Tel: (415) 327-6500
TWX: 910-373-1280

2220 Watt Ave.
Sacramento 95825
Tel: (916) 482-1463
TWX: 910-367-2092

9606 Aero Drive
San Diego 92123
Tel: (714) 279-3200
TWX: 910-335-2000

COLORADO
7965 East Prentice
Englewood 80110
Tel: (303) 771-3455
TWX: 910-935-0705

CONNECTICUT
508 Tolland Street
East Hartford 06108
Tel: (203) 289-9394
TWX: 710-425-3416
111 East Avenue
Norwalk 06851
Tel: (203) 853-1251
TWX: 710-468-3750

FLORIDA
P.O. Box 24210
2806 W. Oakland Park Blvd.
Ft. Lauderdale 33307
Tel: (305) 731-2020
TWX: 510-955-4099

P.O. Box 20007
Herndon Station 32814
621 Commonwealth Avenue
Orlando
Tel: (305) 841-3970
TWX: 810-850-0113

GEORGIA
P.O. Box 28234
450 Interstate North
Atlanta 30328
Tel: (404) 436-6181
TWX: 810-766-4890

ILLINOIS
5500 Howard Street
Skokie 60076
Tel: (312) 677-0400
TWX: 910-223-3613

INDIANA
3839 Meadows Drive
Indianapolis 46205
Tel: (317) 546-4891
TWX: 810-341-3253

LOUISIANA
P.O. Box 856
1942 Williams Boulevard
Kenner 70062
Tel: (504) 721-6201
TWX: 810-955-5524

MARYLAND
6707 Whitestone Road
Baltimore 21207
Tel: (301) 944-5400
TWX: 710-862-0850

P.O. Box 1648
2 Choke Cherry Road
Rockville 20850
Tel: (301) 948-6370
TWX: 710-828-9684

MASSACHUSETTS
32 Hartwell Ave.
Lexington 02173
Tel: (617) 851-8960
TWX: 710-326-6904

MICHIGAN
24315 Northwestern Highway
Southfield 48075
Tel: (313) 353-9100
TWX: 810-224-4882

MINNESOTA
2459 University Avenue
St. Paul 55114
Tel: (612) 645-9461
TWX: 910-563-3734

MISSOURI
11131 Colorado Ave.
Kansas City 64137
Tel: (816) 753-8000
TWX: 910-771-2087
2812 South Brentwood Blvd.
St. Louis 63144
Tel: (314) 962-5000
TWX: 910-760-1670

NEW JERSEY
W. 120 Century Road
Paramus 07652
Tel: (201) 265-5000
TWX: 710-990-4951

1060 N. Kings Highway
Cherry Hill 08034
Tel: (609) 667-4000
TWX: 710-992-4945

NEW MEXICO
P.O. Box 8366
Station C
6501 Lomas Boulevard N.E.
Albuquerque 87108
Tel: (505) 265-3713
TWX: 910-989-1665

156 Wyatt Drive
Las Cruces 88001
Tel: (505) 526-2485
TWX: 910-983-0550

NEW YORK
1702 Central Avenue
Albany 12205
Tel: (518) 869-8462
TWX: 710-441-8270

1219 Campville Road
Endicott 13760
Tel: (607) 754-0050
TWX: 510-252-0890

82 Washington Street
Poughkeepsie 12601
Tel: (914) 454-7330
TWX: 510-248-0012

39 Saginaw Drive
Rochester 14623
Tel: (716) 473-9500
TWX: 510-253-5981

1025 Northern Boulevard
Roslyn, Long Island 11576
Tel: (516) 869-8400
TWX: 510-223-0811

5858 East Molloy Road
Syracuse 13211
Tel: (315) 454-2486
TWX: 710-541-0482

NORTH CAROLINA
P.O. Box 5188
1923 North Main Street
High Point 27262
Tel: (919) 885-8101
TWX: 510-926-1516

OHIO
25575 Center Ridge Road
Cleveland 44145
Tel: (216) 835-0300
TWX: 810-427-9129

3460 South Dixie Drive
Dayton 45439
Tel: (513) 298-0351
TWX: 810-459-1925
1120 Morse Road
Columbus 43229
Tel: (614) 846-1300

OKLAHOMA
2919 United Founders Boulevard
Oklahoma City 73112
Tel: (405) 848-2801
TWX: 910-830-6852

OREGON
Westhill Mall, Suite 158
4475 S.W. Scholls Ferry Road
Portland 97225
Tel: (503) 252-9171
TWX: 910-464-6103

PENNSYLVANIA
2500 Moss Side Boulevard
Monroeville 15146
Tel: (412) 271-0724
TWX: 710-797-3650

1021 8th Avenue
King of Prussia Industrial Park
King of Prussia 19406
Tel: (215) 265-7000
TWX: 510-560-2670

RHODE ISLAND
873 Waterman Ave.
East Providence 02914
Tel: (401) 434-5535
TWX: 710-381-7573

TEXAS
P.O. Box 1270
201 E. Arapahoe Rd.
Richardson 75080
Tel: (214) 231-6101
TWX: 910-867-4723

P.O. Box 22813
6300 Westpark Drive
Suite 100
Houston 77027
Tel: (713) 781-6000
TWX: 910-881-2645

231 Billy Mitchell Road
San Antonio 78225
Tel: (512) 434-4171
TWX: 910-871-1170

UTAH
2890 South Main Street
Salt Lake City 84115
Tel: (801) 487-0715
TWX: 910-925-5681

VERMONT
P.O. Box 2287
Kennedy Drive
South Burlington 05401
Tel: (802) 658-4455
TWX: 710-224-1841

VIRGINIA
P.O. Box 6514
2111 Spencer Road
Richmond 23230
Tel: (703) 265-3431
TWX: 710-956-0157

WASHINGTON
433-108th N.E.
Bellevue 98004
Tel: (206) 454-3971
TWX: 910-443-2303

***WEST VIRGINIA**
Charleston
Tel: (304) 768-1232

FOR U.S. AREAS NOT LISTED:
Contact the regional office nearest you: Atlanta, Georgia... North Hollywood, California... Paramus, New Jersey... Skokie, Illinois. Their complete addresses are listed above.

*Service Only

CANADA

ALBERTA
Hewlett-Packard (Canada) Ltd.
11745 Jasper Ave.
Edmonton
Tel: (403) 482-5561
TWX: 810-831-2431

BRITISH COLUMBIA
Hewlett-Packard (Canada) Ltd.
4519 Canada Way
North Burnaby 2
Tel: (604) 433-8213
TWX: 610-922-5059

MANITOBA
Hewlett-Packard (Canada) Ltd.
511 Bradford Ct.
St. James
Tel: (204) 786-7581
TWX: 610-671-3531

NOVA SCOTIA
Hewlett-Packard (Canada) Ltd.
2745 Outch Village Rd.
Suite 203
Halifax
Tel: (902) 455-0511
TWX: 610-271-4482

ONTARIO
Hewlett-Packard (Canada) Ltd.
880 Lady Ellen Place
Ottawa 3
Tel: (613) 722-4223
TWX: 610-562-1952

Hewlett-Packard (Canada) Ltd.
50 Galaxy Blvd.
Rexdale
Tel: (416) 677-9611
TWX: 610-492-4246

QUEBEC
Hewlett-Packard (Canada) Ltd.
275 Hymus Boulevard
Pointe Claire
Tel: (514) 697-4232
TWX: 610-422-3022
Telex: 01-20607

FOR CANADIAN AREAS NOT LISTED:
Contact Hewlett-Packard (Canada) Ltd. in Pointe Claire, at the complete address listed above.

CENTRAL AND SOUTH AMERICA

ARGENTINA
Hewlett-Packard Argentina
S.A.C.E.I
Lavalle 1171 - 3°
Buenos Aires
Tel: 35-0436, 35-0627, 35-0431
Telex: 012-1009
Cable: HEWPACKARG

BRAZIL
Hewlett-Packard Do Brasil
i.e.C. Ltda.
Rua Frei Caneca 1119
Sao Paulo - 3, SP
Tel: 288-7111, 287-5858
Cable: HEWPACK Sao Paulo

Hewlett-Packard Do Brasil
i.e.C. Ltda.
Rua da Matriz 29
Botafoogo 20-02
Rio de Janeiro, GB
Tel: 246-4417
Cable: HEWPACK Rio de Janeiro

Hewlett-Packard Do Brasil
Industria e Comercio Ltda.
Praca Dom Feliciano 78
Salas 806-8
Porto Alegre RG5

CHILE
Héctor Calcañi y Cia, Ltda.
Bustos, 1932-3er Piso
Casilla 13942
Santiago
Tel: 4-2396
Cable: Calcañi Santiago

COLOMBIA
Instrumentacion
Henrik A. Langebaek & Kier
Ltda.
Carrera 7 No. 48-59
Apartado Aereo 6287
Bogota, 1 D.E.
Tel: 45-78-06, 45-55-46
Cable: AARIS Bogota
Telex: 044-400

COSTA RICA
Lic. Alfredo Gallagos Gardián
Apartado 3243
San José
Tel: 21-85-13
Cable: GALTUR San José

ECUADOR
Laboratorios de Radio-Ingeniería
Calle Guayaquil 1246
Post Office Box 3199
Quito
Tel: 12496
Cable: HORVATH Quito

EL SALVADOR
Electrónica
Apartado Postal 1589
27 Avenida Norte 1133
San Salvador
Tel: 25-74-50
Cable: ELECTRONICA
San Salvador

GUATEMALA
Olander Associates Latin America
Apartado Postal 1226
Ruta 4, 6-53, Zona 4
Guatemala City
Tel: 63958
Cable: OLALA Guatemala City

MEXICO
Hewlett-Packard Mexicana, S.A.
de C.V.
Moras 439
Col. del Valle
Mexico 12, D.F.
Tel: 575-46-49, 575-80-20,
575-80-30

NICARAGUA
Roberto Terán G.
Apartado Postal 689
Edificio Terán
Managua
Tel: 3451, 3452
Cable: ROTERAN Managua

PANAMA
Electrónico Balboa, S.A.
P.O. Box 4929
Ave. Manuel Espinosa No. 13-50
Bldg. Alina
Panama City
Tel: 30833
Cable: ELECTRON Panama City

PERU
Fernando Ereta B.
Avenida Petit Thouars 4719
Miraflores
Casilla 3061
Lima
Tel: 45-2335
Cable: FEPERU Lima

PUERTO RICO
San Juan Electronics, Inc.
P.O. Box 5167
Ponce de Leon 154
Pda. 3-Pla. de Tierra
San Juan 00906
Tel: (809) 725-3342
Cable: SATRONICS San Juan
Telex: SATRON 3450 332

SURINAME
Surtel-Radio Holland N.V.
P.O. Box 155
Paramaribo

URUGUAY
Pablo Ferrando S.A.
Comercial e Industrial
Avenida Italia 2877
Casilla de Correo 370
Montevideo
Tel: 40-3102
Cable: RADIODU Montevideo

VENEZUELA
Hewlett-Packard De Venezuela
C.A.
Apartado 50933
Caracas
Tel: 71.88.05, 71.88.69, 71.99.30
Cable: HEWPACK Caracas

FOR AREAS NOT LISTED, CONTACT:
Hewlett-Packard
INTERCONTINENTAL
3200 Hillview Ave.
Palo Alto, California 94304
Tel: (415) 326-7000
(Feb. 71 493-1501)
TWX: 910-373-1267
Cable: HEWPACK Palo Alto
Telex: 034-8461

EUROPE AFRICA, ASIA, AUSTRALIA



SALES & SERVICE OFFICES

EUROPE

AUSTRIA
Unifabor GmbH
Wissenschaftliche Instrumente
Rummelhardtgasse 6
P.O. Box 33
Vienna A-1095
Tel: (222) 42 61 81, 43 13 94
Cable: LABORINSTRUMENT
Vienna
Telex: 75 752

BELGIUM
Hewlett-Packard S.A. Benelux
348 Boulevard du Souverain
Brussels 1160
Tel: 72 22 40
Cable: PALOEN Brussels
Telex: 23 494

DENMARK
Hewlett-Packard A/S
Dalavej 38
DK-3460 Birkerød
Tel: (01) 81 66 40
Cable: HEWPACK AS
Telex: 66 40

Hewlett-Packard A/S
Torvet 9
DK-8600 Silkeborg
Tel: (06) 827-840

FINLAND
Hewlett-Packard Oy
Bulevardi 26
P.O. Box 12185
Helsinki 12
Tel: 13-730
Cable: HEWPACKOY-Helsinki
Telex: 12-1563

FRANCE
Hewlett-Packard France
Quartier de Courtaboeuf
Boite Postale No. 6
91 Orsay
Tel: 1-920 88 01
Cable: HEWPACK Orsay
Telex: 60048

Hewlett-Packard France
4 Quai des Etoiles
69 Lyon 5ème
Tel: 78-42 63 45
Cable: HEWPACKA Lyon
Telex: 31617

Hewlett-Packard France
29 rue de la Gara
F-31 Blagnac
Tel: (61) 85 82 29
Telex: 51957

GERMANY
Telex: 41 32 45 FRA
Berliner Strasse 117
6 Nieder-Eschbach/Frankfurt 58
Tel: (0611) 50 10 64
Cable: HEWPACKSA Frankfurt
Hewlett-Packard Vertriebs-GmbH
Hewlett-Packard Vertriebs-GmbH
Lützenburgerstrasse 30
1 Berlin 30
Tel: (0311) 211 60 16
Telex: 18 34 05

Hewlett-Packard Vertriebs-GmbH
Herrenbergerstrasse 110
703 88Bilingen, Württemberg
Tel: 07031-8671
Cable: HEPAQ Bbilingen
Telex: 72 65 739

Hewlett-Packard Vertriebs-GmbH
Achenbachstrasse 15
4 Düsseldorf 1
Tel: (0211) 68 52 58/59
Telex: 85 86 533

Hewlett-Packard Vertriebs-GmbH
Wendenstr. 23
2 Hamburg 1
Tel: (0411) 24 05 51/52
Cable: HEWPACKSA Hamburg
Telex: 21 53 32

Hewlett-Packard Vertriebs-GmbH
Reginfriedstrasse 13
8 München 9
Tel: (0811) 69 59 71/75
Cable: HEWPACKSA München
Telex: 52 49 85

GREECE
Kostas Karayannis
18, Ermou Street
Athens 126
Tel: 230301,3,5
Cable: RAKAR Athens
Telex: 21 59 62 RKAR GR

IRELAND
Hewlett-Packard Ltd.
224 Bath Road
Slough, Bucks, England
Tel: Slough 753-33341
Cable: HEWPIE Slough
Telex: 84413

ITALY
Hewlett-Packard Italiana S.p.A.
Via Amerigo Vespucci 2
20124 Milano
Tel: (2) 6251 (10 lines)
Cable: HEWPACKIT Milan
Telex: 32046

Hewlett-Packard Italiana S.p.A.
Palazzo Italia
Piazza Marconi 25
00144 Rome - Eur
Tel: 6-591 2544
Cable: HEWPACKIT Rome
Telex: 61514

NETHERLANDS
Hewlett-Packard Benelux, N.V.
Weerdestein 117
P.O. Box 7825
Amsterdam, Z 11
Tel: 020-42 7777
Cable: PALOEN Amsterdam
Telex: 13 216

NORWAY
Hewlett-Packard Norge A/S
Box 149
Nesveien 13
N-1344 Haslum
Tel: 2-53 83 60
Cable: HEWPACK Oslo
Telex: 16621

PORTUGAL
Telectra
Empresa Tecnica de
Equipamentos
Electricos, S.a.r.l.
Rua Rodrigo da Fonseca 103
P.O. Box 2531
Lisbon 1
Tel: 68 60 72
Cable: TELECTRA Lisbon
Telex: 1598

SPAIN
Enrique Larreta 12
Madrid, 16
Tel: 215 35 43
Cable: TELEATAIO Madrid
Atalo Ingenieros SA
Tel: 27249E
Atalo Ingenieros SA
Ganduxar 76
Barcelona 6
Tel: 211-44-66
Cable: TELEATAIO BARCELONA

SWEDEN (Jan 71)
Hewlett-Packard Sverige AB
Enighetsvägen 1-3
Fack
S-16120 Bromma 20
Tel: (08) 98 12 50
Cable: MEASUREMENTS
Stockholm
Telex: 10721

Hewlett-Packard Sverige AB
Hagakergatan 9C
S 431 04 Malmö 4
Tel: 031 - 27 68 00

SWITZERLAND
Hewlett Packard Schweiz AG
Zürcherstrasse 20
8952 Schlieren
Zürich
Tel: (051) 98 18 21/24
Cable: HPAG CH
Telex: 53933

Hewlett Packard Schweiz A.G.
Rue du Bois-du-Lan 7
1217 Meyrin 2 Geneva
Tel: (022) 41 54 00
Cable: HEWPACKSA Geneva
Telex: 2 24 86

TURKEY
Telekom Engineering Bureau
P.O. Box 376
Karakoy
Istanbul
Tel: 49 40 40
Cable: TELEMANIT Istanbul

UNITED KINGDOM
Hewlett-Packard Ltd.
224 Bath Road
Slough, Bucks
Tel: Slough (0753) 33341
Cable: HEWPIE Slough
Telex: 84413

Hewlett-Packard Ltd.
The Grattons
Stamford New Road
Altrincham, Cheshire
Tel: 061 928-8626
Telex: 668068

YUGOSLAVIA
Belram S.A.
83 avenue des Mimosas
Brussels 1150, Belgium
Tel: 34 33 32, 34 26 19
Cable: BELRAMEL Brussels
Telex: 21790

**SOCIALIST COUNTRIES
PLEASE CONTACT:**
Correspondence Office for
Eastern Europe
Innstrasse 23/2
Postfach
A1204 Vienna, Austria
Tel: (222) 3366 06/09
Cable: HEWPACKA Vienna
Telex: 75923

**ALL OTHER EUROPEAN
COUNTRIES CONTACT:**
Hewlett-Packard S.A.
Rue du Bois-du-Lan 7
1217 Meyrin 2 Geneva
Switzerland
Tel: (022) 41 54 00
Cable: HEWPACKSA Geneva
Telex: 2.24.86

AFRICA, ASIA, AUSTRALIA

ANGOLA
Telectra Empresa Técnica
de Equipamentos Eléctricos
SAR
Rua de Barbosa Rodrigues
42-1º
Box 6487
Luanda
Cable: TELECTRA Luanda

AUSTRALIA
Hewlett-Packard Australia
Pty. Ltd.
22-26 Welr Street
Glen Iris, 3146
Victoria
Tel: 20.1371 (6 lines)
Cable: HEWPARD Melbourne
Telex: 31024

Hewlett-Packard Australia
Pty. Ltd.
61 Alexander Street
Crews Nest 2065
New South Wales
Tel: 43.7866
Cable: HEWPARD Sydney
Telex: 21561

Hewlett-Packard Australia
Pty. Ltd.
97 Churchill Road
Prospect 5082
South Australia
Tel: 65.2366
Cable: HEWPARD Adelaide

Hewlett-Packard Australia
Pty. Ltd.
2nd Floor, Suite 13
Casablanca Buildings
196 Adelaide Terrace
Perth, W.A. 6000
Tel: 21-3330
Cable: HEWPARD Perth

Hewlett-Packard Australia
Pty. Ltd.
10 Woolley Street
P.O. Box 191
Dickson A.C.T. 2602
Tel: 49-8194
Cable: HEWPARD Canberra ACT

CEYLON
United Electricals Ltd.
P.O. Box 681
Yahala Building
Staples Street
Colombo 2
Tel: 5496
Cable: HDTPOINT Colombo

CYPRUS
Kyronics
19 Gregorios & Xenopoulos Road
P.O. Box 1152
Nicosia
Tel: 6282-75628
Cable: HE-I-NAMI

ETHIOPIA
African Salespower & Agency
Private Ltd., Co.
P. O. Box 718
58/59 Cunningham St.
Addis Ababa
Tel: 12285
Cable: ASACO Addisababa

HONG KONG
Schmidt & Co. (Hong Kong) Ltd.
P.O. Box 297
1511, Prince's Building 15th Floor
10, Chater Road
Hong Kong
Tel: 240168, 232735
Cable: SCHMIDTCO Hong Kong

INDIA
Blue Star Ltd.
Kasturi Buildings
Jamsheji Tata Rd.
Bombay 20BR, India
Tel: 29 50 21
Telex: 2396
Cable: BLUEFROST

Blue Star Ltd.
Band Box House
Prabhadevi
Bombay 25DD, India
Tel: 45 73 01
Telex: 2396
Cable: BLUESTAR

Blue Star Ltd.
14/40 Civil Lines
Kanpur, India
Tel: 6 88 82
Cable: BLUESTAR

Blue Star, Ltd.
7 Haré Street
P.O. Box 506
Calcutta 1, India
Tel: 23-0131
Telex: 655
Cable: BLUESTAR

Blue Star Ltd.
Blue Star House,
34 Ring Road
Lajpat Nagar
New Delhi 24, India
Tel: 62 32 76
Telex: 463
Cable: BLUESTAR

Blue Star Ltd.
17-C Ulsoor Road
Bangalore-8

Blue Star, Ltd.
96 Park Lane
Secunderabad 3, India
Tel: 7 63 93
Cable: BLUEFROST

Blue Star, Ltd.
22/24 Second Line Beach
Madras 1, India
Tel: 2 39 55
Telex: 379
Cable: BLUESTAR

Blue Star, Ltd.
18 Kaiser Bungalow
Dindri Road
Jamshejpur, India
Tel: 38 04
Cable: BLUESTAR

INDONESIA
Bah Bolon Trading Coy. N.V.
Djalah Merdeka 29
Bandung
Tel: 4915 51560
Cable: ILMU
Telex: 809

IRAN
Telecom, Ltd.
P. O. Box 1817
240 Kh. Saba Shomali
Tehran
Tel: 43850, 48111
Cable: BASCOM Teheran

ISRAEL
Electronics & Engineering
Div. of Motorola Israel Ltd.
17 Aminadav Street
Tel-Aviv
Tel: 36941 (3 lines)
Cable: BASTEL Tel-Aviv
Telex: Bastei TV 033-569

JAPAN
Yokogawa-Hewlett-Packard Ltd.
Obashi Building
59 Yoyogi 1-chrome
Shibuya-ku, Tokyo
Tel: 03-370-2281/77
Telex: 232-2024YHP
Cable: YHPMARKET TOK 23-724

Yokogawa-Hewlett-Packard Ltd.
Nisei Ibaragi Bldg.
2-2-8 Kasuga
Ibaragi-Shi
Osaka
Tel: 23-1641

Yokogawa-Hewlett-Packard Ltd.
Its Building
No. 59, Kotori-cho
Nakanura-ku, Nagaya City
Tel: 551-0215

Yokogawa-Hewlett-Packard Ltd.
Nitto Bldg.
2300 Shinohara-cho,
Kokoku-ku
Yokohama 222
Tel: (405) 432-1504/5

KENYA
R. J. Tilbury Ltd.
P. O. Box 2754
Suite 517/518
Hotel: Ambassador
Nairobi
Tel: 25670, 68206, 58196
Cable: ARJAYTEE Nairobi

LEBANON
Constantin E. Macridis
Commancheu Street
P.O. Box 7213
Beirut
Tel: 220846
Cable: ELECTRONUCLEAR Beirut

MALAYSIA
MECOMB Malaysia Ltd.
2 Lorong 13/6A
Section 13
Petaling Jaya, Selangor
Cable: MECOMB Kuala Lumpur

MOZAMBIQUE
A. M. Concalves, LDA.
4.1 Apt. 14 Av. D. Luis
P.O. Box 107
Lourenca Marquês
Cable: NEGON

NEW ZEALAND
Hewlett-Packard (N.Z.) Ltd.
32-34 Kent Terrace
P.O. Box 9443
Wellington, N.Z.
Tel: 36-559
Cable: HEWPACK Wellington

Hewlett Packard (N.Z.) Ltd.
Box 51092
Pukuranga
Tel: 373-733

PAKISTAN (EAST)
Mushko & Company, Ltd.
Zirat Chambers
31, Jinnah Avenue
Dacca
Tel: 280058
Cable: NEWDEAL Dacca

PAKISTAN (WEST)
Mushko & Company, Ltd.
Dusman Chambers
Victoria Road
Karachi 3
Tel: 511027, 512927
Cable: COOPERATOR Karachi

PHILIPPINES
Electromex Inc.
Makati Commercial Center
2129 Pasong Tamo
Makati, Rizal D 708
P.O. Box 1028
Manila
Tel: 89-85-01
Cable: ELEMEX Manila

SINGAPORE
Mechanical and Combustion
Engineering Company Ltd.
9, Jajan Kilang
Red Hill Industrial Estate
Singapore, 3
Tel: 642361-3
Cable: MECOMB Singapore

SOUTH AFRICA
Hewlett Packard South Africa
(Pty.) Ltd.
P.O. Box 31715
Braamfontein Transvaal
Milnerton
30 De Beer Street
Johannesburg
Tel: 725-2080, 725-2030
Telex: 0225 JH
Cable: HEWPACK Johannesburg

Hewlett Packard South Africa
(Pty.) Ltd.
Breechastele House
Bree Street
Cape Town
Tel: 3-6019, 3-6545
Cable: HEWPACK Cape Town
Telex: 5-0006

Hewlett Packard South Africa
(Pty.) Ltd.
308 Glenwood Centre
Corner Hunt & Moore Roads
P.O. Box 99
Overport, Natal
Tel: 347536

TAIWAN REP. OF CHINA
Hewlett Packard Taiwan
39 Chung Shiao West
Sec. 1
Overseas Insurance
Corp. Bldg. 7th Floor
Taipei
Tel: 579-605, 579-610, 579-613
Telex: c/o Bankamerica TP 339
Cable: HEWPACK Taipei

THAILAND
The International
Engineering Co., Ltd.
P. O. Box 39
614 Sukhumvit Road
Bangkok
Tel: 910722 (7 lines)
Cable: GYSOM
TLX INTENCO BK-226 Bangkok

VIETNAM
Peninsular Trading Inc.
P.O. Box H-3
216 Hien-Vuong
Saigon
Tel: 20.805
Cable: PENINSULA Saigon

ZAMBIA
R. J. Tilbury (Zambia) Ltd.
P.O. Box 2792
Lusaka
Zambia, Central Africa

**MEDITERRANEAN AND
MIDDLE EAST COUNTRIES
NOT SHOWN PLEASE
CONTACT:**
Hewlett-Packard Correspondence
Office
Piazza Marconi 25
I-00144 Rome-Eur, Italy
Tel: (6) 59 40 29
Cable: HEWPACKIT Rome
Telex: 61514

**OTHER AREAS NOT
LISTED CONTACT:**
Hewlett-Packard
INTERCONTINENTAL
3200 Hillview Ave.
Palo Alto, California 94304
Tel: (415) 326-7000
(Feb. 71 493-1501)
TWX: 910-373-1267
Cable: HEWPACK Palo Alto
Telex: 034-8461

ALPHABETICAL INDEX



See 1971 Supplement for products with
blue page numbers; 1970 Catalog for others

Absorptive Modulators to Computers

A

Absorptive Modulators.....	235, 310
A to D Converter.....	39, 98, 103, 42, 54
AC Amplifiers.....	467
AC Amplifier/DC Power Supply.....	468
AC Calibrator.....	160, 167
AC Converter for 3450A DVM.....	208
AC Current Probe.....	195
AC Meter Calibrator.....	160, 167, 169
AC Microvoltmeter.....	175
AC Power Pack for 204C/D.....	276
AC Probe for 410C VM.....	185
AC Voltmeters	
Analog.....	164, 175, 183
Battery Operated.....	180
Differential.....	164
Digital.....	207, 212, 213, 216, 217 54
True rms.....	181, 209 54
Vacuum Tube.....	179, 185, 187, 188
AC/Ohms Converter.....	217
AC/Ohms Converter DC Preamplifier	
for 3460B.....	217
AC to DC Converter.....	139, 220, 47
AC-DC Converter Module.....	47
AC-DC Differential Voltmeter/DC Standard.....	164
AC/DC Meter Calibrator.....	167
AC/DC Range Unit for 3439A/3440A DVM.....	207
AC/DC Remote Unit for 3439A/3440A DVM.....	207
AC/DC Voltmeter Calibrator.....	167
Accessories	
Acoustics.....	60
Adapters, BNC for 3406A RF VM.....	187
Adapters, BNC to Binding Post.....	283
Analog Recorders.....	151, 152 50
Attenuator.....	283 51
Cable for 3462A and 3460B DVM's.....	216
Cables and Test Leads.....	196
Cable Ass'y for 740B Stan/ Δ VM.....	163
Carrying Cases.....	638, 639
Current Divider for 456A Probe.....	195
DC Power Supplies.....	571
Detectors for 675A sweeper.....	317
Digital Recorders.....	39
For 400 Series VM's.....	176, 177, 195
For 410B/C VM's.....	185
For 3450A DVM.....	211
For 3461A AC/ Ω Converter, Preamp.....	217
Instrument and Combining Cases.....	636
Kit for 411A RF Millivoltmeter.....	187
Kits for 3406A RF Voltmeter.....	187
Oscillator.....	283
Oscilloscope.....	Refer to Oscilloscope Accessories
Oscilloscope.....	534
Oscilloscope Camera.....	542
Oscilloscope Probe.....	100
Probes for 428B VTVM.....	194
Probe, AC Current.....	195
Probe, High Frequency.....	195
Probe Kits for 3406A & 411A.....	187
Accessory Kits	
For 411A RF Millivoltmeter.....	187
For 3406A RF Voltmeter.....	187
For 3701A/2A/3A.....	444, 447
For 4815A RF Vector Impedance Meter.....	223
Acoustic	
Accessories.....	60
Systems.....	63
Technical Information.....	47, 48
Transducers.....	60
Active Probes.....	534 74, 99
Active Probe, 100MHz.....	100
Adapters, 50 to 75 ohms.....	516
Adapter, Binding Post to BNC.....	283
Adapters	
Coax-To-Coax.....	355
For 3406A RF Voltmeter.....	187
Series Loss Test for 4342A.....	59
Waveguide-to-Coax.....	355
Waveguide-to-Waveguide.....	355, 414
Amplifiers	
AC Amplifier/Power Supply.....	468
Bank.....	141
Battery Operated.....	467
DC Preamplifier.....	217 90
Data.....	465
Fast Pulse.....	470
General Purpose.....	467, 470
Logarithmic.....	182
Microwave.....	472
Nuclear Detector.....	44
Power.....	468, 471
Precision AC.....	469
Technical Information.....	462, 463
Transducer.....	153
Traveling Wave.....	472
Vertical, Oscilloscope Plug-in.....	496, 520 103
Wideband.....	233, 52
Analog Magnetic Tape Recorders.....	142, 50
Analog Module Test Systems.....	90
Analog Voltmeters.....	162, 175
Analog Voltmeter, Technical Information.....	170
Analysis, Signal, Digital.....	35-46, 42, 86
Analyzers,	
Automatic Network.....	386, 71
Automatic Spectrum.....	85
Coaxial Fault.....	424
Distortion.....	449
Distortion, Technical Information.....	448
Loudness.....	47, 49, 55
Low Frequency Spectrum.....	402, 88
Microwave Link.....	440
Module Real-Time.....	51
Network.....	372, 71
Noise.....	422, 77
Real-Time Audio Spectrum.....	51
Signal.....	399, 75
Signal Averaging.....	42, 90
Signal, Fourier.....	40, 88
Signal, Multichannel.....	35, 86
Signal, Multiparameter.....	38, 87
Spectrum.....	40, 403, 75, 88
Waveform.....	455, 91
Waveform, Technical Information.....	451
Antenna, VLF Broadcast Receiver.....	625
Assemblies, Microphone.....	60

Atomic Frequency Standards.....	620, 622
Attenuator	
75 ohm.....	444
Accessories.....	283 51
Balanced Output.....	283, 429 51
Coaxial.....	341; 69
Programmable.....	69
Step.....	341, 343, 283, 51, 69
Waveguide.....	344
Audio Data Processor.....	63, 88, 89
Audio Oscillator.....	278, 279
Audio Range Voltmeters (see Voltmeters)	
Audio Signal Generator.....	279
Audio Spectrum Analyzer.....	40, 51, 402 88
Auto Range Selector for 3439A/3440A.....	205
Auto Ranging DVM's.....	203, 216, 218 54
Auto Volt-Ohmmeter.....	188
Automatic Capacitance Bridge.....	227
Automatic Capacitance Measurement.....	225
Automatic Counter.....	602, 603
Automatic Tape Degausser.....	152
Automatic Test Systems.....	90, 93, 112
(Automatic Test Systems.)	
Coupler/Controller.....	43
Averager, Signal, Digital; (see also "Digital Signal Analysis").....	42 90

B

Balanced Mixers.....	235
Balanced Probe for 312A Selective VM.....	460
Bandpass Filters.....	348, 414
Bank Amplifier.....	141
Batch Processing.....	37
Battery Operated Oscillators.....	276, 277, 431
Battery Operated Voltmeters.....	166, 180, 189
Battery Powered Oscilloscopes.....	101
Bench Stand for 297A Sweep Drive.....	458
Binding Post to BNC Adapter.....	283
BNC Adapters.....	535
BNC Male to Binding Post Adapter.....	283
Bridge, Capacitance.....	227
Bridge Measurements.....	224
Bridge, RF.....	228
Bridge, Universal.....	226

C

C Measurements.....	224
Cabinets Modular.....	636, 637
Cable Amplifier.....	60
Cable Assemblies and Test Leads.....	196
Cable Assemblies, Coaxial.....	537
Cable Fault Locator.....	423
Cable, Pressurized, Leak Detector.....	423
Calculator.....	82, 85
Buffer Box.....	34
Coupler/Controller.....	43

Display.....	85
Extended Memory.....	34
Optical Cardreader.....	85
Plotter.....	84, 35
Printer.....	83
Calibration Resistor for 4800A.....	222
Calibrators	
AC.....	160, 167, 169
AC/DC Meter.....	167
AC/DC Voltmeter.....	167
Peak Power.....	391
Power Meter.....	395
Sound Level Voltmeter.....	61, 62, 160, 161, 167
Calorimetric Power Meter.....	398
Cameras, Oscilloscope.....	539
Capacitance Bridge.....	227
Capacitance Measurements.....	224
Capacitive Terminations.....	61
Capacitor, Decade.....	192
Carriages for Slotted Lines.....	354
Carrier Preamplifier.....	137
Carrying Cases.....	638, 639
Cesium Beam Standards.....	620, 621
Character Printer.....	120
Chart Advance, Incremental.....	120
Chart Advance, Manual.....	120
Clip, Logic.....	40
Clip-on AC Current Probe.....	195
Clip-on DC Milliammeter.....	194
Coaxial	
Adapter Kit for 250B.....	228
Attenuators.....	341, 69
Cable Assemblies.....	537
Crystal Detectors.....	345
Directional Couplers.....	341, 359, 74
Fault Analyzer.....	424
Filters.....	348
Instrumentation Tables.....	333
Loads, Fixed & Sliding.....	356
Shorts.....	356
Sliding Loads.....	356
Slotted Lines.....	352
Switches.....	234
Terminations.....	356
Thermister Mounts.....	396
Comb Generators.....	235, 296, 414
Combining Cases.....	638
Communications Technical Information.....	425, 427
Communications Test Equipment.....	425
Communications Test Equipment.....	425, 60
Portable Test Set.....	428, 429
Precision Raster Displays.....	436, 437
Psophometer.....	60
Selective Voltmeters.....	432, 91
Spectrum Analyzer.....	434 80
Telephone Oscillator.....	431 61
Transmission/noise Test Set.....	430
Tutorial.....	425
TV Waveform Oscilloscope.....	438
Video Test Oscillator.....	435
Comparator, Hi, Go, Lo.....	211
Comparator, VLF Time Standard.....	625
Computers.....	67

ALPHABETICAL INDEX *continued*See 1971 Supplement for products with
blue page numbers; 1970 Catalog for others**Controlled Data Distribution System to
Function Generators**

Controlled Data Distribution System	41
Controlled Test Systems	90
Coupler/Controller	43
Data Acquisition Systems	102, 103
Digital	67-72
Interfaces	71
Peripherals	72
Systems	37
Computing Counter	
Fixed Program Shell	578, 579
Input Module	579
Keyboard	577, 578, 581
Plug-in Adapter	579
Systems Programmer	112
Constant Current DC Power Supply	550
Controller, Coupler/Controller	43
Controller, Preset, Counter Plug-in Unit	594
Controllers, Preset, Electronic Counter	608, 614
Converters	
A to D	39, 98, 42, 54
AC/Ohms to DC	217
AC/Ohms & DC Preamplifier	217
AC to DC	139, 217, 220, 47
D to A	87, 99
Logarithmic	182
Microwave Frequency	595, 598, 600
V to F	215
Corona Detector	423
Correlator	40, 415, 88
Counter Assemblies, O.E.M.	610
Counter, Counter/Timers, Electronic	572, 108
Automatic	599, 602
Computing	577 112
Frequency, Tutorial	572
High Frequency (50 MHz and higher)	602, 108
Marker Generator	68, 78
Medium Frequency (below 50 MHz)	602, 108
Preset, Normalizing	594, 608, 614
Ruggedized, MIL	589
Timer, Built-in Digital Voltmeter	606
Tracking Generator	78
Universal	602, 108
Counter Plug-ins	
Frequency Conversion, Video Amplifying, Digital Voltmeter, Preset Limits	591
Counter Summary, 50 and 150 MHz	583
Couplers	
Coupler/Controller	43
Digital	98
Digital Instrument	98, 105, 106
Directional	341, 359, 74
Magnetic Tape	98
Output	98, 105, 106
Punched Card	98
Punched Tape	98
Recorder Output	98
Teleprinter	98
Typewriter	98
Coupling Transformer, for 260A	231
Crossbar Scanner	97
CRT Filters, Colored and Contrast	536
CRT Phosphors/Glossary	543
CRT Viewing Hoods, Oscilloscope	536

Crystal Detector	345
Current Divider, 100:1, for 456A	195
Current Meter	184, 190, 191, 194, 206
Current Probe	195
Current Probe and Amplifier	535
Custom Test Systems	91

D

D Measurements	224
D/A Converter	87
Data Acquisition Systems	100, 101
Computerized	102, 86, 87, 112
Coupler/Controller	43
Tutorial	94
Data Amplifier	465, 466
Data Distribution System	41
Data Processor, Audio	63
DC/AC Differential Voltmeter/DC Standard	164, 165
DC-AC Inverter (for 3960 Series)	151 50
DC Amplifier Module	118
DC Analog Voltmeters	162, 183, 188
DC Attenuator Module	119
DC Coupler Module	118
DC DVM	202, 216, 218, 591, 54, 108-111
DC Differential Voltmeter/DC Standard	162
DC Differential Voltmeter/Ratiometer	166
DC Microvolt-Ammeter	191
DC Null Volt-Ammeter	189
DC Null Voltmeter	188, 189
DC Offset Module	119
DC Power Supplies	
10 kW	565
Accessories	571
Bench	554
Condensed Listing	545
Constant Current	550
Digitally Programmable	86
DPB	553
Dual Power Bench	553
Dual Slot	567
High Stability	548
High Voltage	570
IC Test	569
Klystron	349
Laboratory	556
Low Voltage Rack	560
Medium Power, Dual Range	558
Medium Power Module	552
Medium Voltage	562
Options	571
SCR Regulated	564
Selection Guide	544
Slot	566
Transfer Standard	159
Transistor Bias	385 73
DC Power Supplies/Amplifier	468, 568
DC Power Supplies/Calibrators	548
DC Range Selector for 3439A/3440A	

DVM	205
DC Standard/Differential Voltmeter	162, 163
DC Transfer Standard	159
DC Voltage Divider, 100:1, for 410B/C	185
DC Voltmeters	
Analog	162, 183, 188
Differential	162
Digital	202, 216, 218, 219 54
Decade Capacitor	192
Detector, Crystal	345
Detector, Directional	360
Detector Mount	345, 353, 364
Detector Probes for Slotted Lines	354
Detector, Ultrasonic Translator	423
Detectors for 675A Sweeper	317
Differential Amplifier	464, 465, 466
Digital	
Ammeter	206
Coupler	98, 105
Coupler/Controller	43
Delay Generator	608, 614
Frequency Meter	212, 598
Frequency Synthesizers	627
Logic Module Test System	93
Logic Tester	92, 40
Magnetic Tape Units	79, 39
Marker Generator	68
Module Test Systems	90
Multimeters	203, 216, 217, 54
Ohmmeter	206, 210, 213, 217, 54
Oscillator	280
Power Meter, Microwave	70
Pulse Gen	254
Recorder	107, 108, 110 46
Signal Analyzers, Statistical	35, 86
Voltage Source	88
Voltmeters	197, 216, 54
Voltmeters, AC	207, 209, 210, 213, 217, 54
Voltmeters, DC	202, 216, 218, 54
Voltmeter, Plug-in	203, 54
Voltmeter, Technical Information	197
Direct Access Vertical Plug-in for 183	98-99
Directional Couplers	341, 359, 74
Directional Detectors	360
Disc Operating System	37
Displacement Transducers	153
Display, Precision Raster	436, 437
Display, Solid State Numeric	236
Display, X-Y	488, 94, 96
Display, X-Y, Storage	94, 96
Distortion Analyzer	449, 450
Distortion Analyzer, Technical Information	448
Divider for 425A V-AM	191
Divider, Frequency Automatic	598
Divider Probe for 400 Series VM's	195
Divider Tip 10:1 for 3406A RF VM	187
DME/ATC Test Set	308
Double Balanced Mixers	235
Doubler Probe for 3200B	289
Driver, Frequency Synthesizer	635
Dual Slot Power Supplies	567
DVM Technical Information	197

E

Educational Computer System	77
Electronic Counters; see "Counters"	587, 588
Enclosures, Modular	636

F

Fault Analyzer, Coaxial	424
Fault Locator, Cable	423
Fault Locator, Open	423
Feed through Terminations 50, 75 & 600 Ω	283
Feed through Termination 50 & 100 Ω	535
Field Cases	638, 639
Field Service Oscilloscopes	101
Filters, Coaxial & Waveguide	348
Filters for Spectrum Analyzers	414
Filter, Low Pass	90
Filter Module	119
Filter Sets	58
Fixed and Pivot Slides, Oscilloscope	536
Fixture, Transistor	385, 73
FM-AM Signal Generator	288, 290, 291
FM Discriminator	616
FM Frequency Source	152
FM Signal Generator	307
Fourier Analyzer	40 88
Frequency	
Comb Generators	235, 296, 414
Converter, Microwave	596, 600
Converter Plug-in	595
Doubler	296
Doubler Probe	289
Doubler Sets	306
Meter, Digital	599
Meters, Electronic	212, 616
Meters, Waveguide & Coax	346
Multipliers	235, 592, 51
Multiplier Plug-in	592
Synthesizers	630, 632, 67
Synthesizers, Tutorial	628, 629
Frequency and Time Measurement; Tutorial Article	572
Frequency and Time Standards; Tutorial Article	617
Frequency Comparator, VLF Broadcast	625
Frequency Counters; see "Counters"	
Frequency; Divider, Microwave	598
Frequency Marker for 675A Sweeper	317
Frequency Measurement System, Wideband to 40 GHz	601
Frequency Meter/FM Discriminator	616
Frequency Standards	617
Cesium	620
Quartz	624
Rubidium	622
Frequency Synthesis, Tutorial Article	628
Frequency Synthesizer, Programmer	629
Friction Detector, Ultrasonic	423
Function Generators	272, 316, 61
Analog Programmed	273, 316, 61
Plug-in for 3300A	275, 316
Sweeper	275, 316
Technical Information	267
Variable Phase	272

Fuse Holder, RF to Noise Sources

Voltage Controlled.....	273-275, 316 61
Fuseholder, RF.....	295

G

G-Band (3.95-5.85 GHz) Waveguide Instrumentation.....	335
General Purpose Amplifier.....	467, 468, 470
General Purpose Digital Computers.....	67
Generators	
Frequency Comb.....	235, 296, 414
Function.....	272, 316 61
Function, Technical Information.....	267
Marker.....	68
Noise, Coax & Waveguide.....	350, 351
Noise, Pseudo Random.....	262
Precision Noise.....	57
Pulse.....	237
Signal, Aircraft Test.....	308, 309
Signal, FM.....	307
Signal FM-AM.....	288, 290
Signal HF.....	286
Signal SHF.....	302
Signal, Sources.....	237, 328 see also Oscillators
Signal, Telemetry.....	291, 307
Signal, UHF.....	297
Signal VHF.....	292, 293
Sweep.....	312-328 62, 67, 78
Sweep, Technical Information.....	312-315
Tracking.....	78-79
Word.....	239
Word, Plug-in.....	261
Glide Slope Signal Generator.....	309
Glossary, Oscilloscope.....	543
Go-No-Go Comparator.....	211
Graphic Plotter.....	80, 36
Group Delay: Microwave Link Analyzer.....	440

H

Harmonic Mixers.....	355
H-Band (7.05-10.0 GHz) Waveguide Instrumentation.....	337
HF Signal Generator.....	286
HF-VHF Signal Generator Accessories.....	294
High Frequency Probe for VM's.....	195
High Gain/Auto Range Unit for 3440A DVM.....	205
High Pass Filters for Sampling Oscilloscopes.....	513
High Resistance Meter.....	193
High Voltage Amplifier for 745A AC Calibrator.....	160
Hi-Go-Lo Comparator.....	211
Hum Filter, 60 & 400 Hz for 1415A.....	516

I

IF Noise Source.....	350
Impedance Adapter for 675A, 676A Network Analyzer.....	373
Impedance Meters.....	222, 223
Impedance and Phase Measurements.....	221, 366

Impedance Probe.....	74
Impulse Sound Level Meters.....	49
Incremental Chart Advance.....	120
Inductance Measurements.....	221
Inductance Meters.....	222, 228
Inductors.....	229, 231
Inductors for 4342A Q Meter.....	59
Inductors, Reference.....	229
Insert Voltage Adapter.....	60
Instrument Cases.....	638
Instrument Enclosures.....	638
Instrumentation Magnetic Tape Recorders.....	142, 50
Integrating Digital Voltmeter.....	212, 606, 108
Integrating/Dual Slope DVM.....	208
Integrating Potentiometric DVM.....	216, 218
Interfaces, Computer.....	71 38
IRIG-Instrumentation Recording.....	142, 50
Inverter, DC-AC (for 3960).....	151 50

J

J-Band (5.3-8.2 GHz) Waveguide Instrumentation.....	336
---	-----

K

K-Band (18-26.5 GHz) Waveguide Instrumentation.....	340
Kits, Probe for 3406A RF VM.....	187
Kits, Probe for 411A RF VM.....	187
Kits, Probe Tip Oscilloscope Probes.....	535
Klystron Power Supplies.....	349

L

L Measurements.....	224
Leak Detector, Ultrasonic.....	423
Limit Selector for 3450A Op. 003 DVM.....	211
Limit Test Plug-in for 3450A DVM.....	211
Limiters, Coaxial.....	234
Line Follower.....	120
Line Matching Transformer.....	283
Linear Displacement Transducer.....	153
Linear Velocity Transducer.....	154
Locator, Cable Fault.....	423
Locator, Open Fault.....	423
Logarithmic AC VM's.....	176
Logarithmic Converter/Amplifier.....	182
Logarithmic Voltmeter.....	182
Logic Module Test System.....	93
Logic Probe; Logic Clip.....	92 40
Loop Adapter for 3960.....	50
Loudness Analyzer.....	55, 56
Low Frequency Function Generators.....	272, 316, 61
Low Frequency Oscillator.....	276
Low Frequency Voltmeters.....	See Voltmeters
Low Level Multiplexer.....	98, 104
Low Pass Filter.....	348 90

M

Magnetic Tape Coupler.....	98
Magnetic Tape Units	
Analog.....	142, 50
Digital.....	79, 39
Magnetometer Probe for 428B clip-on Ammeter.....	194
Manual Chart Advance.....	120
Marker Generator.....	68
Measurement System, (to 40 GHz).....	601
Meters	
Ammeters, Analog.....	184, 189, 193
Ammeter, Clip-on.....	194, 195
Ammeter, Digital.....	206
Calibrator, AC.....	160, 161, 167, 169
Calibrator, AC/DC.....	167
Calibrator, Precision AC.....	160, 161
Digital VM's.....	202, 216, 606, 54, 108
Frequency, Analog.....	616
Frequency, Digital.....	599
Frequency, Waveguide & Coax.....	346
High Resistance.....	193
Impulse Sound Level.....	49
Inductance.....	228-230
Kilovoltmeters.....	162, 177, 183, 184, 188, 203, 216, 54
Logarithmic.....	176, 182
Microvoltmeter.....	175, 189, 191
Milliammeter.....	184, 190, 191, 194, 195, 206
Milliohmmer.....	192
Millivoltmeter.....	162, 175, 202, 216, 54
Multifunction, Analog.....	162, 183, 188, 193
Multifunction Differential.....	164
Multifunction, Digital.....	202, 216, 217, 54
Noise Figure.....	350
Ohmmeters.....	183, 188, 190, 192, 206, 210, 213, 217, 54
Optical Power.....	32
Phase/Magnitude.....	222, 223, 372
Portable Multifunction.....	183
Power.....	389, 70
Q.....	229, 230, 58
Radiant Flux.....	32
Ratio.....	166, 202, 208, 365, 54
RF Vector Impedance.....	223
RX.....	228
Sound Level.....	49
SWR.....	363, 364
Vacuum Tube Multifunction.....	185, 190, 191
Vector Impedance.....	222, 223
Voltmeters AC Analog.....	164, 175, 183
Voltmeters, AC Differential.....	164, 165
Voltmeter AC Digital.....	207, 212, 213, 216, 217, 54
Voltmeter DC Analog.....	162, 175
Voltmeters DC Differential.....	162
Voltmeters DC Digital.....	202, 216, 218, 606 54, 108
Microphone	
Assemblies.....	60
Power Supply.....	60
Preamplifier.....	60, 62
Microwave	
Amplifiers.....	233, 472, 52
Attenuators.....	342, 69
Detectors.....	345
Link Analyzer.....	440

Mixers.....	235, 355, 414
Modulators.....	235, 310, 311
Network Analyzers.....	379, 72
Oscillators.....	233
Power Meters.....	392, 70
Signal Generators.....	298, 67
Solid State Devices.....	232
Spectrum Analyzers.....	409; 82
Sweepers.....	320, 62
Switches.....	234, 347
Test Equipment.....	329, 595, 599, 601
Test Equipment, Technical Information.....	329
Transistors.....	232
Milliammeters.....	190, 191, 194, 195, 206
Milliammeter, Clip-on DC.....	194
Milliammeter, Clip-on Probe, AC.....	195
Milliohmmer.....	192
Mixers.....	235, 355, 414
Modular Enclosure Accessories.....	638, 639
Modulators.....	235, 310
Module	
AC-DC Converter.....	47
DC Amplifier.....	118
DC Attenuator.....	119
DC Coupler.....	118
DC Offset.....	119
High Sensitivity.....	47
Multiple Span.....	125 47
Null Detector.....	118
Scanner.....	119
Single Span.....	125
Temperature.....	125
Testers.....	90, 93
Time Base.....	118
Monitor, TV Picture.....	436, 437
Motion Transducers.....	153, 154
Mount, Detector.....	345, 353, 364
Mount, Thermistor, Waveguide & Coax.....	396, 397
Multichannel Analyzer.....	35, 37 86, 87
Multifunction Meters	
Analog.....	162, 183, 188, 193
Differential.....	162
Digital.....	202, 216, 217, 54
Multifunction Unit for 3439A/3440A DVM.....	206
Multiple Span Module.....	125 47
Multiplexer, Low Level.....	98, 104
Multiplexer, RF Signal.....	327
Multiplexer, Scanner.....	97, 98
Multiprogrammer System.....	41

N

Narrow Band TDR.....	106
Network Analyzer.....	372, 71
Network Analyzer, Low Frequency.....	372
Network Analyzer Technical Information.....	366
N.I.M. (Nuclear Instrumentation Modules).....	44
Noise Figure Meter.....	350
Noise Generator, Precision.....	57
Noise Generator: Pseudo-Random.....	262
Noise Sources, Waveguide & Coax.....	350

Normalizing Preset Counters to R Measurements

Normalizing Preset Counters.....	594, 608
Nuclear Instrumentation	
N.I.M. Power Supplies.....	44
Preamplifier Unit.....	44
Pulse Height Analyzers (MCA).....	35, 37, 86, 87
Scaler/Timer.....	45, 46
Null Detector.....	188
Null Detector Module.....	118
Null Detector, Recorder.....	120
Null Voltmeters, dc.....	188, 189

O

OEM Tape Units.....	79, 39
Ohm/AC Converter for 3460B DVM.....	217
Ohmmeters ..183, 188, 190, 192, 193, 206, 210, 213, 217, 54	
Ohms Converter for 3450A DVM.....	211
Open Fault Locator.....	423
Optical Detector.....	32
Optical Mark Readers.....	78, 79
Optical Power Meter.....	32
Optoelectronic Devices.....	236 31
Oscillators.....see Generators, Function Generators, Signal Sources, Sweepers, Signal Generators	
Audio and Ultrasonic.....	272, 316, 431, 435, 61
Battery Operated.....	276, 277, 431, 61
Communications.....	431, 435, 61
Crystal Controlled.....	272, 624
Digital.....	280
Function Generator Technical Information.....	267
Low Distortion.....	272, 276, 278
Low Frequency.....	272, 279, 316, 61
Portable.....	276, 277, 431, 61
Pushbutton.....	277, 629
Quartz.....	624
Sinusoidal.....	272, 316, 431, 435, 61
Sweep.....	275, 312, 62
Technical Information.....	267
Telephone Test.....	431, 61
Test.....	281, 282, 431, 435, 61
Tracking for 312A Wave Analyzer.....	433, 460
Ultra Low Frequency.....	272, 316, 61
VHF.....	289
Wide Range.....	272, 278, 281, 282, 435, 61
Oscillographic Recorder 1 Channel Thermal.....	127, 130
Oscillographic Recorder, 2 Channel Thermal.....	127, 131
Oscillographic Recorder, 4 Channel Thermal.....	132
Oscillographic Recorder, 6 & 8 Channel Thermal.....	133
Oscillographic Recorder, 6, 8, or 16 Channel Thermal.....	140
Oscillographic Recorder, 8 Channel, Ink.....	134, 141
Oscillographic Preamplifiers.....	136
Oscilloscope Accessories.....	534
Active Probes.....	534, 100
Adapters, BNC to Banana.....	535
Adapters BNC to Probe.....	535
Adapters (1415A) 50 to 75Ω.....	516
Adapters for Slides.....	536
Amber Contrast Filter, CRT.....	536
Bandwidth Limiter, 1120A.....	534
Blank Plug-ins 140 Series.....	536
Blank Plug-ins 180 Series.....	536

Blue Contrast Filter, CRT.....	536
Cameras.....	539, 540, 541
Bezel Adapters.....	542
Carrying Case.....	542
Film Backs.....	542
Coaxial Cables.....	537
CRT Contrast Filters.....	536
CRT Viewing Hoods.....	536
Current Probe and Amplifier.....	534
Divider, 10:1 for 1120A.....	534
Divider, 100:1 for 1120A.....	534
Drawers for Testmobiles.....	538
Feed through Termination 100Ω.....	535
Fixed and Pivot Slides and Adapters.....	536
Green Contrast Filters, CRT.....	536
Hum Filter for 1415A.....	516
Panel Cover for 180A, 181A, 183A.....	537
Panel Cover with Accessories for 1551A.....	537
Panel Cover for 1200 Series Cabinet Models.....	537
Passive Probes, 1:1 and Divider.....	536
Plug-in Extenders 140 & 180 Series.....	537
Probes, Oscilloscope.....	536, 537
Probe Power Supply.....	534
Probe Tip Kits.....	535
Probe Tip for 1410A Sampling.....	508
Resistive Divider Kit for 50Ω Inputs.....	534
Risetime Converters, TDR Accessories.....	516
Sampling Accessories for 1410A.....	508, 513
Terminations, 50 and 100Ω.....	535
Testmobiles, Oscilloscope.....	538
Tilt Trays for Testmobiles.....	538
Vinyl Cover, 180A, 181A.....	537
Voltage Divider Probes.....	536
Oscilloscopes.....	473, 92
Oscilloscopes, Field Service.....	101
Oscilloscopes, Instruments.....	424
Oscilloscopes, Low Frequency.....	477, 92, 93
Oscilloscope, Mainframe.....	97
Oscilloscope, plug-in.....	104
Oscilloscopes, Plug-in 140 Series.....	491
Oscilloscopes, Plug-in, 180 Series.....	518, 97, 103
Oscilloscope Plug-in for 183 System.....	98
Oscilloscope Plug-in Selection Charts.....	496, 520
Oscilloscope Plug-in, Vertical Amplifier.....	103
Oscilloscope, Sampling Head.....	104
Oscilloscope Sampling Plug-in.....	105
Oscilloscope Selection Chart.....	476
Oscilloscope, 7 MHz.....	92
Oscilloscope, TV Waveform.....	438
Oscilloscope, X-Y Display.....	94
Output	
Coupler.....	98
Recorder Coupler.....	98

P

P-Band (12.4-18 GHz) Waveguide Instrumentation.....	339
Pack Sensor.....	152
Parallel Output Reader.....	79
Patch Panel for 3550B Telephone Test Set.....	283, 429
PC Board Testing.....	90, 93

Peak Power Calibrator.....	391
Peripherals, Computer.....	72 38
Phase/Amplitude Tracking Detector.....	372
Phase and Impedance Measurements.....	221, 366
Phase, Differential: Microwave Link Analyzer.....	440
Phase-Lock Function Generator.....	274
Phase-Lock Synchronizer.....	294, 327
Phase Measurement Equipment (see Network Analyzer)	
Phase Sensitive Demodulator.....	138
Phase Shifter, Waveguide.....	358
Piezo-Electric Accelerometer.....	60
Pivot and Fixed Slides Oscilloscope.....	536
Plotter, Calculator.....	35
Plotter, Graphic.....	80, 36
Plug-in Digital Voltmeter.....	203, 54
Plug-in Function Generator.....	274, 316
Plug-in Pulse Generators.....	254
Plug-in Oscilloscopes.....	491
Plug-in Selective Voltmeter.....	432
Plug-in Sweep Oscillators.....	322
Plug-in Wave Analyzers.....	455
Plug-in Adapter Counter.....	579
Plug-ins, Electronic Counters.....	591
Point Plotter.....	119
Point Plotting System.....	121
Portable AC Voltmeter.....	180
Portable Instrumentation Tape Recorder.....	149, 50
Portable Multifunction Meter.....	183
Portable Oscillators.....	276, 277, 431, 61
Portable Test Set.....	428, 429
Portable Transmission, Noise Measuring Set.....	430, 60
Power Amplifier.....	468, 471
Power Meters.....	389, 32, 70
Power Meters, Optical.....	32
Power Supplies	
Amplifier.....	568
Condensed Listing.....	545
DC, Constant Current.....	550
DC Regulated.....	544
Digitally-Programmable.....	86
Klystron.....	349
Microphone.....	60
SCR Regulated.....	563
Selection Guide.....	544, 547
Transistor Bias.....	385
Power Supplies, Frequency Standard.....	627
Power Supplies, Nuclear.....	44
Preamplifier AC-DC Converter.....	139, 47
Preamplifier, AC/Ohms Converter.....	217
Preamplifier, 8 Channel.....	141
Preamplifier-Filter Combination.....	90
Preamplifier, Log Level.....	139
Preamplifier, Low Gain dc.....	136
Preamplifier, Low Level.....	137
Preamplifier, Medium Gain.....	136
Preamplifier, Microphone.....	60
Preamplifier, Nuclear Detector.....	44
Preamplifier, Phase Sensitive Demodulator.....	138
Preamplifier, RF.....	233, 52
Preamplifier, Signal Coupler.....	138
Precision AC Amplifier.....	469
Precision AC Calibrator.....	160, 167, 169
Precision Analog Voltmeters.....	162
Precision Analog Voltmeters & Sources, Tech. Info.....	155
Precision DC Transfer Standard.....	159
Precision Noise Generator.....	57
Precision Raster Display.....	436, 437
Precision VM's and Sources, Technical Information.....	155
Prescaler and DVM Counter Plug-ins.....	591
Preselector for Spectrum Analyzer.....	413
Preset-Counter-Controllers.....	608, 614, 615
Preset Counter, Plug-in Unit.....	594
Pressurized Cable Leak Detector.....	423
Printer, Digital, Line.....	107, 46
Probe and Probe Accessories, Oscilloscope.....	534
Probes	
AC Current.....	195
AC 500 MHz Active Probe.....	74
Accessory Kit for 4815A.....	223
Active.....	74
Current.....	195
Current Divider.....	195
Digital Logic Test.....	92 40
Divider 10:1 for 3406A RF VM.....	187
Frequency Doubler for 3200B VHF Osc.....	289
High Frequency for VM's.....	195
Impedance Probe.....	74
Kit for 411A RF mVM.....	187
Kit for 3406A RF VM.....	187
Logic.....	92 40
Magnetometer for 428B.....	194
Slotted Line.....	352
Voltage Divider.....	176, 185, 187, 191, 195
Processor, Audio Data.....	63-65
Programmable Attenuators.....	69
Programmable Test Systems.....	386, 71, 85
Program Shell for 5360A.....	579
Programmer, Frequency Synthesizer.....	629
Programmer, Scanner.....	97
Psophometer.....	60
Pulse Generators.....	237
Pulse Generators, Plug-in.....	254
Pulse Generator Selection Chart.....	238
Pulse Height Analyzer.....	35 86
Punched Card Coupler.....	98
Punched Tape Coupler.....	98
Punched Tape Readers.....	72 38
Push Button Oscillator.....	277
Q	
Q Measurements.....	224
Q Meter.....	229, 58
Q Standards.....	231 59
Quartz Oscillator.....	624
Quartz Thermometer.....	113
R	
R-Band (26.5-40 GHz) Waveguide Instrumentation.....	340
R Measurements.....	224

ALPHABETICAL INDEX *continued***Rack Mount Kit to VLF Comparator**

Rack Mount Kit for 3960.....	151
Rack Slide Mounting Kit.....	50
Radiant Flux Detector.....	32
Radiant Flux Meter.....	32
Raster Display, Precision.....	436, 437
Ratio Meter.....	166, 208, 365, 54
Readers-Punched Tape.....	72 38
Real-Time Audio Spectrum Analyzer.....	51
Real-Time Executive System.....	76
Receiver Test Systems.....	90
Rechargeable Battery Pack for 204C/D.....	276
Recorders	
Accessories.....	120
Analog.....	142, 50
Digital.....	79, 105, 106, 39, 46
Null Detector.....	120
Oscillographic 1 Channel Thermal.....	127, 130
Oscillographic 2 Channel Thermal.....	127, 131
Oscillographic 4 Channel Thermal.....	132
Oscillographic, 6 & 8 Channel Thermal.....	133
Oscillographic, 6, 8, & 16 Channel Thermal.....	140
Oscillographic, 8 Channel, Ink.....	134, 141
Output Coupler.....	98
Sound Level.....	49
Strip Chart 5.....	126, 48
Strip Chart 10".....	124, 48
X-Y 8½ x 11.....	113
X-Y 11 x 17.....	113, 115
X-Y 2 Pen.....	115
Recording Systems—Magnetic Tape.....	79, 142, 39, 50
Reed Scanner.....	97
Reflection Measurement Equipment.....	359, 365, 372, 73, 74
Reflection/Transmission Test Units.....	374, 379, 73
Reflectometer Equipment.....	359, 365, 383, 384, 74
Reflectometer Technical Information.....	330, 368
Regulated Power Supplies.....	544
Remote Control Option for 3960.....	50
Remote Start/Stop Switch.....	151
Reproduce Track Selector.....	152
Resistance Measurements.....	224
Resistivity Cell.....	193
RF	
Amplifiers.....	233 52
Millivoltmeter.....	186, 187
Network Analyzers.....	372, 71
Power Meters.....	391, 70
Signal Generators.....	286, 78
Spectrum Analyzers.....	403, 78
Sweepers.....	312, 317, 62
Testing.....	90, 91
Vector Impedance Meter.....	223
Vector Voltmeter.....	377
RMS, True, Voltmeter.....	181, 209, 54
Rotary Air Lines & Joints, Coax.....	347
Rubidium Frequency Standard.....	622, 623
RX Meter.....	228
Sampling Plug-ins.....	528, 507, 105
Sampling RF Voltmeter.....	186
Scanner	
Crossbar.....	97
Input.....	97
Module.....	119
Programmer.....	97
Reed.....	97
SHF Signal Generators.....	302
Short, Coax & Waveguide.....	356, 357
Signal Analysis, Digital; see "Analyzers" and "Digital"	
Signal Analyzers.....	42, 43, 399, 75
Signal Generators.....	284, 311, 67, 78
FM.....	307
FM-AM.....	388, 290, 291
HF.....	286, 287
SHF.....	302
Technical Information.....	284
Telemetry.....	291, 307
UHF.....	297
VHF.....	292
Signal Sources.....	237, 328, 62, 78
Audio Frequency.....	272, 316, 431, 435, 61
Low Frequency.....	272, 279, 316, 61
Pulse Generators.....	237
Signal Generators.....	284, 78
Sweepers.....	312
Wideband.....	272, 278, 281, 282, 435, 61
Sine/Square Oscillator.....	276
Single Span Module.....	125
Slide-Screw Tuners, Waveguide.....	358
Slides, Fixed and Pivot Oscilloscopes.....	536
Sliding Load, Waveguide & Coax.....	356
Slot Power Supplies.....	566, 567
Slotted Line Equipment.....	352
Solid State Devices.....	236
Sound Level Calibrator.....	60-62
Sound Level Recorder.....	49
Source, Signal.....	267, 289, 61
Sources, Signal Generators.....	290, 307
Source, Sweep Generator.....	312
Spectrum Analyzers.....	399, 80
Spectrum Analyzer Preselector.....	413
Spectrum Generator.....	296
Square Wave Generators.....	237
Stabilized Microwave Source.....	67
Standards, Inductance.....	231
Standards, Q.....	231
Standby Power Supply.....	627
Statistical Analysis, Signal; see "Analyzers" and "Digital"	
Strip Chart Recorder 5".....	126, 48
Strip Chart Recorder 10".....	124, 48
Strip Chart Recorder Tutorial.....	122
Subsystems, High Speed Data Acquisition.....	103
Sweep Drive for 302A, 310A, 312A Wave Analyzers.....	458
Sweep, Generators.....	312
Sweep/Network Analysis.....	328, 372
Sweep/Offset Plug-in for 3300A.....	275, 316
Sweep Oscillators.....	312, 62
Sweep Plug-in for 3300A Function Generator.....	316
Sweeper.....	316
Sweepers, Technical Information.....	312
S-Parameters (Technical Information).....	371
S-Parameter Test Set.....	384, 72

S

Sweeping Signal Generator.....	317
Swept-Frequency Measurements, Technical Information ..	312
Swept Frequency Plug-in.....	514
Swept Slotted Line.....	352
Switch, Coaxial.....	234, 347
SWR Meters.....	363, 364
Synchronizer, Phase Lock.....	294, 327
Synthesizer Driver.....	635
Synthesizer, Microwave.....	67
Synthesizer Programmer.....	629
System, Point Plotting.....	121
Systems	
Automatic Network Analyzer.....	386
Automatic Spectrum Analyzer.....	85
Controllers.....	98
Coupler/Controller.....	43
Custom.....	90
Data Acquisition.....	100, 101
Data Amplifier.....	466
Frequency Measurement.....	577, 601 112
Multichannel Analyzer.....	38, 39, 86, 87
Network Analyzer.....	374, 379, 72
Nuclear.....	38, 39, 86, 87
Sweeper.....	327, 67

T

Tape Recorders, Analog.....	142, 50
Tape Recorders, Digital.....	79 39
Tape Servo.....	152
Telephone Test Oscillator.....	431 61
Telephone Test Set.....	428
Teleprinter Coupler.....	98
Temperature Module.....	125
Terminal Shield for 4800A.....	222
Terminations	
50-Ohm Feed-Thru.....	283
75-Ohm Feed-Thru.....	283
600-Ohm Feed-Thru.....	283
Capacitive.....	61
Coaxial, Fixed & Sliding.....	356
Waveguide, Fixed & Sliding.....	357
Test Leads.....	196
Test Oscillator.....	277, 281, 282, 431, 435 61
Test Set, DME/ATC.....	308
Test Systems	
Analog Module.....	90
Automatic.....	90, 93
Computer Controlled.....	90, 386, 71, 85
Coupler/Controller.....	43
Custom Module.....	90
Network Analysis.....	374, 379, 71
Programmable.....	577, 112
Tester, Digital Logic, Probe Clip.....	92, 40
Testmobiles, Oscilloscope.....	538
Thermal Converters, AC to DC.....	165
Thermistor Mounts.....	396, 397
Thermistor Power Meter.....	394, 395 70
Thermometer.....	113

Time and Frequency Measurements: see "Frequency"

Time Base.....	120
Time Base Delay Gen for 183.....	100
Time Base Module.....	118
Time Domain-Reflectometer Plug-ins.....	439, 515, 528
Time Interval Counters, Precise.....	577, 584, 604, 606 108
Time Interval Measurement; see Frequency Tutorial	
Article.....	572
Time Interval Plug-in for 5360A.....	580
Time Interval Units, Counter Plug-in.....	580, 592, 593
Time-Shared Basic System.....	74
Time-Shared Systems, Coupler/Controller.....	43
Tracking Generator.....	78
Tracking Oscillator for 312A.....	460, 433
Transducers, Acoustics.....	60
Transducer, Amplifier.....	153
Transducer, Linear Displacement.....	153, 154
Transducer, Linear Velocity.....	154
Transfer Oscillator Plug-in.....	597
Transistor Bias Supply.....	385
Transistor Fixture.....	385, 73
Transistors, Microwave.....	232
Transistor Noise Analyzer.....	422, 77
Transistor Socket Kit for 4470B.....	77
Transit Case (for 3960 Series).....	151
Translator Detector, Ultrasonic.....	423
Transmission & Noise Measuring Set.....	430, 60
Transmission Measurements (Tech. Info.).....	331, 366
Transmission/Reflection Test Units.....	374, 379, 73
Trigger/Phase Lock Plug-in for 3300A.....	275
True RMS AC Voltmeter.....	181, 209, 54
Tutorial, TDR.....	439
TV Monitors.....	436, 437
TV Waveform Oscilloscope.....	438

U

UHF Noise Source.....	350
UHF Signal Generators.....	297
ULF Receiver, Frequency Comparator.....	625
Ultrasonic Translator Detector.....	423
Universal Bridge.....	226
Univerter.....	291

V

Vacuum Tube Multifunction Meter.....	185, 190, 191
Vacuum Tube Voltmeter.....	179, 187, 188
Vector Impedance Meters.....	222, 223
Vector Voltmeter.....	377
VHF Noise Source.....	350
VHF Oscillator.....	289
VHF Signal Generators.....	292
Video Amplifier Plug-in.....	592
VLF Comparator.....	625
Voice Channel (3950, 3955).....	152

Voice Channel to X-Y Recorder

Voice Channel (3960).....	151	X-Y Recorder 11 x 17.....	113, 115
Voltage Divider, 100:1 DC, for 410 B/C.....	185	X-Y Recorder, 2 Pen.....	115
Voltage Divider 1000:1, for 425A VM.....	191	X-Y Recorder, Tutorial.....	112
Voltage Divider, 1000:1 Capacity, 10:1 Resistance for 400 Series VM's.....	195		
Voltage Divider Probes.....	536		
Voltage-to-Frequency Converter.....	215		
Voltmeters			
AC Analog.....	164, 165, 175, 183		
AC Calibrator.....	160, 161, 167, 169		
AC Differential.....	164, 165		
AC Digital.....	207, 212, 213, 216, 217, 54		
AC True RMS.....	181, 209, 54		
AC/DC Calibrator.....	167		
Analog Technical Information.....	170		
Audio Range.....	49-50		
Calibrator.....	160, 161, 167		
Converter AC/Ohms, DC Preamplifier.....	217		
DC Analog.....	161, 183, 188		
DC Differential.....	162		
DC Digital.....	202, 216, 218, 591, 606, 54, 108		
Digital, Technical Information.....	197		
Logarithmic.....	176, 182		
Multifunction Analog.....	162, 183, 188, 193		
Multifunction Differential.....	162		
Multifunction Digital.....	203, 216, 217, 54		
RF Vector.....	377		

W

Wave Analyzer.....	40, 455, 88, 89, 91
Wave Analyzer, Technical Information.....	451
Waveguide	
Adapters.....	355, 414
Attenuators.....	344
Crystal Detectors.....	345
Directional Couplers.....	362
Filters.....	348
Instrumentation Tables.....	335
Loads, Sliding & Fixed.....	357
Mixers.....	355, 414
Noise Sources.....	350
Phase Shifter.....	358
Shorts.....	357
Slide Screw Tuners.....	358
Slotted Line Equipment.....	352
Stands & Clamps.....	355
Terminations, Sliding & Fixed.....	357
Thermistor Mounts.....	396
Word Generator.....	239, 261

X

X-Band (8.2-12.4 GHz) Waveguide Instrumentation.....	338
X-Y Displays.....	490, 94
X-Y Displays, Storage.....	94, 95
X-Y Recorder 8½ x 11.....	113

See 1971 Supplement for products with
blue page numbers; 1970 Catalog for others



MODEL NUMBER INDEX

F-3B Line Follower \$895	120
G-2B Null Detector \$325	120
2FA 11" x 17" 2 pen X-Y Recorder \$3375	115
3LV1 Transducer, Linear Velocity \$55	154
3LVA5 Transducer, Linear Velocity \$55	154
6LV1 Transducer, Linear Velocity \$55	154
6LV2 Transducer, Linear Velocity \$55	154
6LV3 Transducer, Linear Velocity \$55	154
7 30 x 30 X-Y Recorder Obsolete	
7DCDT Transducer, Linear Displacement (DC) \$100	154
7LV6 Transducer, Linear Velocity \$85	154
7LV9 Transducer, Linear Velocity \$100	154
7LV20 Transducer, Linear Velocity \$120	154
24DCDT Transducer, Linear Displacement (DC) \$145	154
53 Battery Converter	128

100

105A Quartz Oscillator \$1650	624
105B Quartz Oscillator \$1950	624
117A VLF Comparator \$1550	625
120B 450 kHz Oscilloscope \$585	477
122A,AR 200kHz Oscilloscope \$1000	478
130C 500 kHz, 300 μ V/cm Oscilloscope \$890	479
132A Dual Beam Oscilloscope \$1475	480
135 8½" x 11" X-Y Recorder \$1650	114
135A 8½" x 11" X-Y Recorder \$1650	114
136A 8½" x 11" 2 pen X-Y Recorder \$2650	115
140A Plug-In Oscilloscope Main Frame \$795	493
140B Plug-In Oscilloscope Main Frame \$695	493
140S Replaced by 140T	
140T Spectrum Analyzer - Display Section \$875	403, 80
141A Plug-In Storage Oscilloscope Main Frame \$1600	494
141B Plug-In Storage Oscilloscope Main Frame \$1500	494
141S Replaced by 141T	
141T Spectrum Analyzer - Display Section \$1700	403, 80
143A Large Screen Plug-In Oscilloscope Main Frame \$1500	495
143S Spectrum Analyzer - Display Section \$1500	403, 80
180A Plug-In Oscilloscope Main Frame \$895	521
181A Plug-In Storage Oscilloscope Main Frame \$1850	522
181AR Plug-In Storage Oscilloscope Main Frame \$1925	522
182A Oscilloscope Main Frame \$1100	97
183A Oscilloscope High Writing Speed Scope Main Frame \$1750	530
183B Oscilloscope High Writing Speed Scope Main Frame \$1825	530
183C,D Oscilloscope Main Frame, Transient Viewing \$2500	98
190A Q Meter \$1475	229
191A TV Waveform Oscilloscope \$1775	438
195A High Speed Oscilloscope Camera \$975	539
197A Oscilloscope Camera \$595	540
198A General Purpose Oscilloscope Camera \$375	541

200

200AB Audio Oscillator \$255	278
200CD Wide-Range Oscillator \$295	278

201C Audio Oscillator \$315	278
202C Low Frequency Oscillator \$350	279
202H FM-AM Signal Generator \$1595	290
202J FM-AM Signal Generator \$1725	291
203A Variable-Phase Function Generator \$1295	272
204C Oscillator \$260	276
204D Oscillator \$335	276
205AG Audio Signal Generator \$750	279
207H Univerter \$595	291
208A Test Oscillator \$585	277
209A Sine/Square Oscillator \$355	276
211A Crystal monitored Sig Gen \$2900	309
211A Square wave Generator Obsolete	
211B Square Wave Generator \$450	246
213B Pulse Generator (100 ps) \$300	248
214A Pulse Generator \$975	250
215A Pulse Generator \$2200	251
216A Pulse Generator \$1775	252
218AR Digital Delay Generator Obsolete	
220A Square Wave Generator \$225	247
221A Square Wave Generator \$225	247
222A Pulse Generator \$750	253
230B Power Amplifier \$1190	471
232A Glide Slope Signal Generator \$3200	309
236A Telephone Test Oscillator \$600	431
236A Opt H10 Telephone Test Oscillator \$650	61
241A Pushbutton Oscillator \$510	277
250B RX Meter \$2475	228
260A Q Meter \$1350	230
281 A,B Series Waveguide-to-Coax Adapters	355
292 A,B Series Waveguide-to-Waveguide Adapters	355
297A Sweep Drive \$445	458
299A 1 Channel Portable Oscillographic Recorder \$875	127

300

301 1 Channel Portable Oscillographic Recorder \$950	127
302A Wave Analyzer \$2085	458
302AR Wave Analyzer \$2070	458
310A Wave Analyzer \$2695	459
311A Transducer Amplifier/Indicator \$600	153
312A Wave Analyzer \$4275	433,460
313A Tracking Oscillator \$1400	433,460
320 2 Channel Portable Oscillographic Recorder \$2095	127
321 2 Channel Portable Oscillographic Recorder \$2125	127
322A 2 Channel Portable Oscillographic Recorder \$1850	127
331A Distortion Analyzer \$680	449
332A Distortion Analyzer \$710	449
333A Distortion Analyzer \$920	449
334A Distortion Analyzer \$950	449
340B Noise Figure Meter \$1000	350
342A Noise Figure Meter \$1100	350
343A VHF Noise Source \$150	350
345B IF Noise Source \$200	350
347A Series Waveguide Noise Sources	350
349A UHF Noise Source \$325	350
350C Attenuator Set Obsolete	
350D Attenuator Set \$165	283
353A Patch Panel \$290	283,429
354A Coax Step Attenuator \$350	343

355C, D to 1831A, B

355C,D Coax Step Attenuators \$160 (each).....	341
355E,F Programmable Step Attenuators \$275 (each).....	69
360 Series Coax Low Pass Filters.....	348
362A Series Waveguide Variable Low Pass Filters.....	348
375A Series Waveguide Variable Attenuators.....	344
382 Series Waveguide Variable Attenuators.....	344
393A,394A Variable Coax Attenuators \$675 each.....	341

400

400D Vacuum Tube Voltmeter \$325.....	179
400E High Accuracy AC Voltmeter \$345.....	178
400E, EL AC to DC Converter.....	220
400EL High Accuracy AC Voltmeter \$355.....	178
400F Fast Response Voltmeter \$330.....	176
400FL Fast Response Voltmeter \$340.....	176
400GL High Frequency DB Voltmeter \$350.....	177
400H Vacuum Tube Voltmeter \$385.....	179
400L Vacuum Tube Voltmeter \$385.....	179
403A AC Portable Voltmeters \$360.....	180
403B AC Portable Voltmeters \$350.....	180
410B Vacuum Tube Voltmeter \$315.....	185
410C Multifunction Voltmeter \$515.....	184
411A RF Millivoltmeter \$525.....	187
412A Voltmeter, Ammeter, Ohmmeter \$475.....	190
413A DC Null Voltmeter \$410.....	188
414A Auto Voltmeter \$785.....	188
415B SWR Indicator \$500.....	364
415E SWR Meter \$425.....	363
416B Ratio Meter \$1000.....	365
419A DC Null Volt-Ammeter \$475.....	167,189
420A,B Coax Crystal Detectors.....	345
422A Series Waveguide Crystal Detectors.....	345
423A Coax Crystal Detector \$150.....	345
424A Series Waveguide Crystal Detectors.....	345
425A DC Microvolt-Ammeter \$585.....	191
425AR DC Microvolt-Ammeter Obsolete	
427A Multi-Function Meter \$250.....	183
428B Clip-on DC Milliammeter \$675.....	194
430C Microwave Power Meter \$450.....	397
432A Microwave Power Meter \$525.....	394
432B Microwave Power Meter (Digital) \$975.....	70
434A Calorimetric Power Meter \$2100.....	398
440A Detector Mount \$100.....	353
442B Slotted Line Probe \$60.....	354
444A Slotted Line Detector Probe \$65.....	354
446B Slotted Line Detector Probe \$250.....	354
447B Slotted Line Detector Probe \$125.....	354
448B Slotted Line Sweep Adapter \$400.....	353
450A Stabilized Amplifier \$230.....	467
456A AC Current Probe \$250.....	195
457A AC to DC Converter \$500.....	220
461A General Purpose Amplifier \$360.....	470
462A Fast Pulse Amplifier \$360.....	470
463A Precision AC Amplifier \$735.....	469
465A General Purpose Amplifier \$245.....	468
466A General Purpose Amplifier \$205.....	467
467A Power and Voltage Amplifier \$610.....	468
477B Coax Thermistor Mount \$125.....	397
478A Coax Thermistor Mount \$175.....	396
X485B Waveguide Detector Mount \$125.....	364
486A Series Waveguide Thermistor Mounts.....	396

487B Series Waveguide Thermistor Mounts.....	397
489A,491C Microwave Amplifiers \$2450 (each).....	472
493,495A Microwave Amplifiers \$2800 (each).....	472

500

501 Tripod Obsolete	
532 Series Waveguide Frequency Meters.....	346
536A Coax Frequency Meter \$500.....	346
537A Coax Frequency Meter \$525.....	346
561B Digital Recorder Obsolete	
562A Digital Recorder \$1285.....	109
565A Digital Recorder \$950.....	110
571B Digital Clock \$1300.....	108
580A Digital-Analog Converters \$600.....	111
581A Digital-Analog Converters \$625.....	111
585DT Transducer, Linear Displacement (AC) \$65.....	153
595DT Transducer, Linear Displacement (AC) \$50.....	153

600

606A HF Signal Generator \$1540.....	286
606B HF Signal Generator \$1650.....	286
608E VHF Signal Generator \$1790.....	292
608F VHF Signal Generator \$1940.....	292
612A UHF Signal Generator \$1750.....	297
614A UHF Signal Generator \$2600.....	300
616B UHF Signal Generator \$2600.....	300
618C SHF Signal Generator \$2500.....	302,303
620B SHF Signal Generator \$2500.....	302,303
623B,C SHF Test Set Obsolete	
624B,C X-Band Test Set Obsolete	
626A SHF Signal Generator \$4200.....	304
628A SHF Signal Generator 4200.....	304
651B Test Oscillator \$625.....	281
652A Test Oscillator \$755.....	281
653A Test Oscillator \$1030.....	435
654A Test Oscillator \$910.....	282
675A Sweeping Signal Generator \$2400.....	317
675A,676A Network Analyzer.....	372
676A Phase/Amplitude Tracking Detector \$1450.....	372
680 5" Strip Chart Recorder \$800.....	126

700

712C DC Power Supply, Medium Voltage \$545.....	562
715A Klystron Power Supply \$550.....	349
716B Klystron Power Supply \$1050.....	349
721A DC Power Supply, Bench \$165.....	555
735A DC Transfer Standard \$435.....	159
738BR Voltmeter Calibration System \$1225.....	167
740B DC Standard/Differential Voltmeter \$2545.....	162
741B AC-DC Differential Voltmeter/DC Standard \$1945.....	164
745 AC Calibrator \$4615.....	160
746A High Voltage Amplifier for the 745A \$2050.....	160
752 series Waveguide Directional Couplers.....	362
770 series Coax Dual Directional Couplers.....	360
778D Coax Dual Directional Coupler \$450.....	359

779D Coax Directional Coupler \$550.....	359
780 series Coax Directional Detectors.....	360
790 series Coax Directional Couplers.....	360

800

805C Coax Slotted Line \$900.....	354
809C Carriage 810B series Waveguide Slotted Sections.....	353
814B Carriage \$575.....	354
815B series Waveguide Slotted Sections.....	353
816A Coax Slotted Section \$280.....	352
817A Coax Swept Slotted Line System \$1000.....	352
851B Spectrum Analyzer - Display Section \$2575.....	409
852A Spectrum Analyzer - Display Section \$3575.....	409
870A series Waveguide Slide-screw Tuners.....	358
885A series Waveguide Phase Shifters.....	358
890A DC Power Supply, Medium Voltage \$495.....	562
895A DC Power Supply, Medium Voltage \$625.....	562

900

910 Series Waveguide Terminations.....	357
X913A Waveguide Termination \$175.....	357
914 series Waveguide Moving Loads.....	357
920 series Waveguide Moving Shorts.....	357
X930A Waveguide Shorting Switch \$300.....	357
P932A Waveguide Harmonic Mixer \$350.....	355
934A Coax Harmonic Mixer \$150.....	355
938A, 940A Frequency Doubler Sets \$2800 (each).....	306

1000

1051A, 1052A Combing Cases.....	638
1104A 18GHz Countdown Supply \$200.....	513
1105A 20 ps Pulse Generator Supply \$200.....	513
1105A/1106A Pulse Generator (20 ps) \$750.....	248
1105A/1108A Pulse Generator (60 ps) \$400.....	248
1106A Trigger Countdown \$550.....	513
1107A Hum Filter for 1415A TDR Plug-in \$325.....	516
1108A Trigger Countdown \$200.....	513
1109A High Pass Filter \$200.....	513
1110A AC Current Probe \$125.....	535
1111A Amplifier for 1110A \$200.....	535
1116A Testmobile \$95.....	538
1117B Testmobile \$225.....	538
1118A Testmobile \$120.....	538
1119A Testmobile \$110.....	538
1119B Testmobile \$145.....	538
1119C Testmobile \$110.....	538
1119D Testmobile \$145.....	538
1120A 500 MHz Active Probe \$350.....	534
1121A AC Probe \$350.....	74
1122A Probe Power Supply \$225.....	534
1123A 220MHz Active Probe \$350.....	534
1124A Active Probe, Oscilloscope Accessory \$95.....	100
1129A High Pass Filter \$100.....	513
1200A,B Dual Trace Oscilloscope \$1050.....	481

1201A,B Dual Trace Storage Oscilloscope \$1900.....	482
1202A,B 500 kHz, 100 μ V/div. Oscilloscope \$790.....	484
1205A,B 500 kHz, 5mV/div. Dual Trace Oscilloscope \$895.....	485
1206A,B 500 kHz, 5mV/div. Oscilloscope \$715.....	486
1207A,B 500 kHz, 5mV/div. Storage Oscilloscope \$1550.....	486
1208A,B 600 kHz X-Y Display \$540.....	488
1208B Opt H12 X-Y Display, Storage, 600 kHz \$1450.....	96
1215A,B 7mHz, 5mV Oscilloscope \$950.....	92
1217A,B 7mHz, 5mV Dual Trace Oscilloscope \$1175.....	93
1300A 20mHz Large Screen X-Y Display \$2000.....	489
1330A 1mHz X-Y Display \$800.....	94
1331A,C 1mHz Storage X-Y Display \$1575.....	94
1400B 500kHz, 100 V/div Plug-in for 140 Series \$275.....	501
1401A 450kHz, Dual Trace Plug-in for 140 Series \$450.....	501
1402A 20mHz, Dual Trace Plug-in for 140 Series \$575.....	498
1403A Differential Plug-in for 140 Series \$575.....	503
1404A 15mHz, 4-Channel Plug-in for 140 Series \$975.....	504
1405A 5mHz, Dual Trace Plug-in for 140 Series \$350.....	499
1406A Differential/DC Offset Plug-in for 140 Series \$950.....	500
1407A Differential Plug-In for 140 Series Obsolete.....	505
1408A Dual Trace Plug-in for 140 Series.....	502
1410A 1GHz Sampling Plug-in for 140 Series \$1700.....	507
1411A 12.4GHz Sampling Plug-in for 140 Series \$700.....	509
1415A Time Domain Reflectometer Plug-in for 140 Series \$1200.....	515
1416A Swept Frequency Indicator Plug-in for 140 Series \$900.....	514
1420A Time Base Plug-in for 140 Series \$375.....	505
1421A Time Base/Delay Generator for 140 Series \$675.....	506
1422A Time Base for 140 Series \$250.....	505
1423A Time Base for 140 Series \$490.....	505
1424A Sampling Time Base for 140 Series \$1400.....	511
1425A Sampling Time Base/Delay for 140 Series \$1900.....	512
1430A Sampler Head for 140 Series (28 ps) \$3000.....	510
1431A Sampler Head (18GHz) \$3500.....	104
1431A Sampler Head for 140 Series (28 ps) \$3000.....	510
1432A Sampler Head for 140 Series (90 ps) \$1000.....	509
1551A Ruggedized Oscilloscope with Plug-ins \$3100.....	533
1580A,B Narrow Band TDR \$6000.....	106
1700A Field Service Oscilloscope \$1680.....	101
1701A Field Service Oscilloscope \$1850.....	101
1801A 50mHz Dual Trace Plug-in for 180 Series \$695.....	523
1801A Opt 001 Plug-in Amplifier for 180 System \$845.....	103
1802A 100 MHz Dual Trace Plug-in for 180 Series \$1200.....	526
1803A Differential/DC Offset Plug-in for 180 Series \$950.....	523
1804A 50 MHz, 4-Trace Plug-in for 180 Series \$1050.....	524
1806A 500 kHz Amplifier for 180 System \$675.....	104
1810A 1GHz Sampling Plug-in for 180 System \$1650.....	105
1815A,B TDR/Sampler Plug-in for 180 Series \$1100.....	528
1816A Sampling Head for 1815A,B \$850.....	529
1817A Sampling Head for 1815A,B \$1500.....	529
1820A Time Base Plug-in for 180 Series \$575.....	525
1820B Time Base Plug-in for 180 Series \$525.....	527
1821A Time Base/Delay Generator Plug-in for 180 Series \$800.....	525
1822A Time Base/Delay Generator Plug-in for 180 Series \$900.....	527
1830A 250 MHz Dual Trace Plug-in for 183 \$850.....	532
1831A,B Direct Access Vertical Plug-in.....	98

1840A to 6102

1840A Time Base Plug-in for 183 \$650.....	532
1841A Time Base/Delay Generator for 183 System \$1150.....	100
1900A Pulse Generator Main Frame \$850.....	256
1901A Pulse Generator Main Frame \$450.....	256
1905A Rate Generator (25 MHz) Plug-in \$200.....	257
1906A Rate Generator (125 MHz) Plug-in \$275.....	257
1908A Delay Generator (25 MHz) Plug-in \$200.....	258
1910A Delay Generator (125 MHz) Plug-in \$200.....	258
1915A Variable Transition Time Output Plug-in \$1700.....	259
1917A Variable Transition Time Output Plug-in \$525.....	260
1920A Transition Time Output (25 MHz) Plug-in (350 ps) \$1925.....	261

2000

2000A Time-Shared Basic System.....	74
2005A Real Time Executive System.....	76
2007A Educational Computer System.....	77
2010K,L,M,N Data Acquisition Systems From \$9890.....	100
2012A,B,C,D Data Acquisition Systems.....	100
2014A,B, Data Acquisition Systems.....	100
2020 Digital Magnetic Tape.....	79
2060A Digital Logic Module Test System.....	93
2114A System Controllers Obsolete	
2114B Computer.....	67
2115A Computer Obsolete	
2116B Computer.....	67
2212A Voltage to Frequency Converter \$1260.....	215
2310A High Speed Data System \$6155.....	103
2310B High Speed Data System \$7425.....	103
2310C High Speed Data System \$5590.....	103
2311A High Speed Data System \$3550.....	103
2312A High Speed Data System \$9400.....	103
2320A Low Speed Data Subsystem.....	102
2321A Low Speed Data Subsystem.....	102
2322A Low Speed Data Subsystem.....	102
2323A Low Speed Data Subsystem.....	102
2401C Integrating Digital Voltmeter \$4300.....	214
2402A Integrating Digital Voltmeter \$5955.....	212
2410B AC/Ohms Converter \$2750.....	98
2470A Data Amplifier \$725.....	465
2471A Differential Amplifier \$640.....	466
2547A Coupler, Digital Instrument.....	105
2570A Coupler/Controller \$1625.....	43
2590B Frequency Converter.....	600
2748A Punched Tape Readers.....	38
2758 Punched Tape Readers.....	38
2759B Frequency Synthesizer Programmer \$4500.....	629
2760A Optical Mark Reader Obsolete	
2761A Optical Mark Readers.....	78
2761A-007 Parallel Output Reader.....	79
2781A Pacer.....	103
2801A Quartz Thermometer \$3250.....	113
2901A Input Scanner/Programmer \$2600.....	97
2902A Slave Input Scanner/Programmer \$2075.....	97
2911A Crossbar Scanner \$2950.....	97
2911B Crossbar Scanner \$2650.....	97
2912A Reed Scanner \$3500.....	97
2920A Combing Case for 2912A \$1500.....	97
2921A Low Voltage DC Module for 2912A \$600.....	97
2922A High Voltage DC/AC Module for 2912A \$600.....	97

2923A Frequency Module for 2912A \$600.....	97
2930A Low Level Multiplexer \$3600.....	104
2940A Cabinet, Enclosures From \$750.....	636

3000

3030 Digital Magnetic Tape.....	79
3200B VHF Oscillator \$595.....	289
3205A FM Signal Generator \$5750.....	307
3300A Function Generator \$725.....	274
3301A Auxiliary Plug-in for 3300A \$30.....	274
3302A Trigger/Phase Lock Plug-in for 3300A \$255.....	275
3304A Sweep/Offset Plug-in for 3300A \$295.....	275
3305A Sweep Plug-in for 3300A \$1015.....	275
3310A Function Generator \$595.....	273
3310A Opt H10 Function Generator \$735.....	61
3400A RMS Voltmeter \$600.....	181
3400A RMS AC to DC Converter \$600.....	220
3406A Broadband Sampling Voltmeter \$795.....	186
3410A AC Microvoltmeter \$895.....	175
3420A DC Differential Voltmeter/Ratiometer \$1400.....	166
3420B DC Differential Voltmeter/Ratiometer \$1550.....	166
3430A DC Digital Voltmeter \$700.....	202
3439A Plug-in Digital Voltmeter \$1015.....	203
3440A Plug-in Digital Voltmeter \$1225.....	203
3441A Range Selector for 3439A/3440A \$50.....	205
3442A Automatic Range Selector for 3439A/3440A \$165.....	205
3443A High-Gain/Auto Range Unit for 3439A/3440A \$535.....	205
3444A Multi-Function Unit for 3439A/3440A \$615.....	206
3445A AC/DC Range Unit for 3439A/3440A \$615.....	207
3446A AC/DC Remote Unit for 3439A/3440A \$640.....	207
3450A Digital Multi-Function Meter \$3300.....	208
3460B Digital Voltmeter \$3850.....	216
3461A AC/Ohms Converter, DC Preamplifier \$2700.....	217
3462A Digital Voltmeter (Six Digit) \$4995.....	218
3480A,B Digital Voltmeter.....	54
3481A Buffer Amplifier (Plug-in) \$350.....	55
3482A DC Range Unit (Plug-in) \$700.....	56
3484A Multifunction Unit (Plug-in) \$900.....	56
3528A Large Aperture Current Probe for 428 \$525.....	194
3529A Magnetometer Probe for 428B \$95.....	194
3550B Portable Test Set \$1255.....	428
3555B Telephone Testmeter \$650.....	430
3556A Psophometer \$800.....	60
3590A Wave Analyzer \$3280.....	455
3591A Plug-in Selective Voltmeter \$3435.....	432
3592A Auxiliary Plug-in \$80.....	456
3593A Sweeping Local Oscillator Plug-in \$1130.....	457
3594A Sweeping Local Oscillator Plug-in \$1640.....	455
3595A Sweeping Local Oscillator Plug-in \$1250.....	91
3603A Automatic Tape Degausser \$1090.....	152
3604A Voice Channel \$550.....	152
3605A FM Frequency Source \$675.....	152
3680A AC Power Supply \$1100.....	152
3681A Tape Servo \$1380.....	152
3701A/3702A/3703A Microwave Link Analyzer \$7500.....	440
3721A Correlator \$8300.....	415
3722A Noise Generator \$2650.....	262
3722A Opt H01 Modified Noise Generator \$2950.....	266
3750A Attenuator - 75 Ohm \$135.....	444



3907-11A Remote Control Unit \$385.....	152
3950 Series Magnetic Tape Recorders \$12,790.....	142, 50
3955 Series Magnetic Tape Recorders \$9200.....	142, 50
3960 Series Portable Recorder \$4470.....	144, 149, 50

4000

4022A Frequency Multiplier \$760.....	51
4204A Digital Oscillator \$750.....	280
4260A Universal Bridge \$595.....	226
4270A Automatic Capacitance Bridge \$4825.....	227
4328A Milliohm Meter \$495.....	192
4329A Resistance Meter \$750.....	193
4342A Q Meter \$1500.....	58
4436A Attenuator (balanced output) \$300.....	51
4437A Attenuator (unbalanced output) \$255.....	51
4440B Decade Capacitor \$270.....	192
4470A Transistor Noise Analyzer \$4450.....	422
4470B Transistor Noise Analyzer \$3950.....	77
4800A Vector Impedance Meter \$1650.....	222
4815A RF Vector Impedance Meter \$2650.....	223
4900A Cable Fault Locator \$655.....	423
4901A Cable Fault Locator \$765.....	423
4904A Cable Fault Locator \$995.....	423
4905A Ultrasonic Translator Detector \$595.....	423
4910B Open Fault Locator \$635.....	423
4916A Ultrasonic Translator Detector \$525.....	423
4917A Leak & Friction Detector \$575.....	423
4918A Leak & Friction Detector \$850.....	423
4920A Coaxial Fault Analyzer \$1825.....	424
4950A Ultrasonic Translator Detector Obsolete	

5000

5050B Digital Recorder \$1900.....	107
5055A Digital Recorder \$1150.....	46
K02-5060A Standby Power Supply \$2850.....	627
5061A Cesium Beam Frequency Standard \$14,800.....	620
5065A Rubidium Frequency Standard \$7500.....	622
5085A Standby Power Supply \$1700.....	627
5100B Frequency Synthesizer Driver \$8150.....	632
5102A Frequency Synthesizer \$7200.....	630
5103A Frequency Synthesizer \$7800.....	630
5105A Frequency Synthesizer \$10,250.....	632
5110B Frequency Synthesizer Driver \$4350.....	632
5201L Scaler-Timer, Pulse Height Analyzer \$2095.....	45
5210A Frequency Meter/FM Discriminator \$750.....	616
5216A Electronic Counter \$985.....	612
5221A Electronic Counter \$425.....	610
5221B Electronic Counter \$775.....	610
5240A Digital Frequency Meter \$4900.....	599
5245L Electronic Counter \$2675.....	584
5245M Electronic Counter \$3300.....	584
M54-5245L Electronic Counter.....	589
5246L Electronic Counter \$1900.....	590
5248L Electronic Counter \$2900.....	587
5248M Electronic Counter \$3675.....	587
M54-5248M Electronic Counter.....	589
5251A Frequency Converter Plug-in \$575.....	595
5252A Prescaler Plug-in \$885.....	591
5253B Frequency Converter Plug-in \$650.....	595
5254C Frequency Converter Plug-in \$900.....	595

5255A Frequency Converter Plug-in \$2050.....	595
5256A Frequency Converter Plug-in \$2150.....	595
5257A Transfer Oscillator Plug-in \$2400.....	597
5258A Prescaler Plug-in \$1000.....	591
5260A Automatic Frequency Divider \$3900.....	598
5261A Video Amplifier Plug-in \$500.....	592
5262A Time Interval Plug-in \$350.....	592
5264A Preset Plug-in \$825.....	594
5265A Digital Voltmeter Plug-in \$800.....	591
5267A Time Interval Counter Plug-in \$475.....	593
5268A Frequency Multiplier Plug-in \$650.....	592
5280A Reversible Electronic Counter Obsolete	
5285A Universal Input Plug-in Obsolete	
5321A Electronic Counter \$425.....	610
5321B Electronic Counter \$775.....	610
5323A Automatic Counter \$1295.....	602
5325B Universal Electronic Counter \$1500.....	604
5326A Universal Counter/Timer \$1195.....	606, 607
5326B Universal Counter/Timer/DVM \$1550.....	108
5326C Electronic Counter \$950.....	108
5327A Universal Counter/Timer \$1695.....	110
5327C Electronic Counter \$1450.....	108
5330A Normalizing Preset Counters \$1250.....	608
5330B Normalizing Preset Counters \$1650.....	608
5331A,B Obsolete	
5332A Obsolete	
5332B Preset Controllers/Counters \$1300.....	614
5360A Computing Counter \$6500.....	577
5365A Computing Counter Input Module (included in 5360A).....	577, 112
5375A Computing Counter Keyboard \$1350.....	581
5376A Systems Programmer \$1350.....	112
5379A Time Interval Plug-in for 5360A \$750.....	580
5401B Multichannel Analyzer \$10,600.....	35
5402A Multichannel Analyzer.....	86
5402A Multichannel Analyzer.....	86
5403A Multichannel Analyzer System.....	86
5405A, 5406A Replaced by 5406B	
5406B Nuclear Analyzer System.....	87
5411A Analog to Digital Converter.....	42
5450A Fourier Analyzer \$50,700.....	88
5452A Fourier Analyzer \$30,500 (typical system).....	89
5480B Signal Averager \$6800.....	90
5480S Signal Averager System \$9950.....	90
5481A Signal Averager System \$28, 450.....	90
5489A Low Pass Filter \$425.....	90
5525A Laser Interferometer \$11,500.....	31
5554A Preamplifier \$360.....	44
5580A NIM Power Supply \$995.....	44
5582A Linear Amplifier \$750.....	750
5583A Single Channel Analyzer \$650.....	45
5584A Dual Timing Pickoff \$900.....	45
5585A Fast Coincidence \$900.....	45
5586A Spectrum Stabilizer \$2500.....	42
5590A Scaler-Timer \$1875.....	45
5610A A to D Converter \$2000.....	99
5636 H-Band Test Set Obsolete	

6000

6101 DC Power Supply, STB \$265.....	548
6102 DC Power Supply, STB \$265.....	548

7878A 8 Channel Oscillographic Recorder, Ink \$9500.....	141
7970A Digital Magnetic Tape Unit \$4700.....	39

8000

8002A Pulse Generator \$750.....	240
8003A Pulse Generator \$500.....	240
8004A Pulse Generator \$750.....	243
8005A Pulse Generator \$1100.....	242
8006A Word Generator \$1100.....	239
8010A Pulse Generator \$1925.....	244
8051A Loudness Analyzer \$5,925.....	55
8052A Impulse Sound Level Meter \$740.....	49
8054A Real-Time Audio Spectrum Analyzer \$9325.....	51
8055A Filter Set \$600.....	58
8056A Filter Set \$2025.....	58
8057A Precision Noise Generator \$800.....	57
8060A Real Time Spectrum Module \$4200.....	51
8062A Impulse Sound Level Meter \$795.....	49
8320A, 8321A, 8324A Stabilized Microwave Sources.....	67
8330A Radiant Flux Meter \$650.....	32
8334A Radiant Flux Detector \$450.....	32
8403A Modulator \$900.....	310
8404A Leveling Amplifier \$395.....	328
8405A Vector Voltmeter \$2850.....	377
8406A Frequency Comb Generator \$650.....	414
8407A Network Analyzer \$2950.....	374, 74
8410A Network Analyzer Mainframe \$2100.....	383
8410S Network Analyzer Systems.....	379, 72
8411A Harmonic Frequency Converter \$2600.....	383
8412A Phase-Magnitude Display \$1575.....	374, 72
8413A Phase-Gain Indicator \$1150.....	383
8414 Polar Display \$1300.....	374, 383
8418A Auxiliary Power Supply \$500.....	384
8430-Series Bandpass Filters.....	348, 414
8439A Notch Filter \$450.....	413
8441A Preselector \$2950.....	413
8442A Crystal Filter \$250.....	413
8443A Tracking Generator/Counter \$3500.....	78
8447-Series Wideband Amplifiers.....	52
8457A-Series Programmable Microwave Synthesizer.....	67
8470A Coax Crystal Detector \$190.....	345
8471A Coax Crystal Detector \$50.....	345
8472A Coax Crystal Detector \$175.....	345
8477A Power Meter Calibrator \$475.....	395
8478B Coax Thermistor Mount \$300.....	396
8491-Series Coax Attenuators.....	342
8492-Series Coax Attenuators.....	342
8493-Series Coax Attenuators.....	342
8542A Automatic Network Analyzer.....	386
8543A Automatic Network Analyzer.....	71
8551B Spectrum Analyzer - RF Section \$8250.....	409
8552A Spectrum Analyzer - IF Section \$2150.....	403, 82
8552B Spectrum Analyzer - IF Section \$2850.....	80
8553B Spectrum Analyzer - RF Section \$2200.....	80
8554L Spectrum Analyzer - RF Section \$3500.....	403
8555A Spectrum Analyzer - RF Section \$5975.....	82
8580A Automatic Spectrum Analyzer.....	85
8600A Digital Marker \$1100.....	68
8601A Generator/Sweeper \$2250.....	318, 288
8614A Signal Generator \$2490.....	298

8614B Signal Source \$1900.....	298
8616A Signal Generator \$2490.....	298
8616B Signal Source \$1900.....	298
8620-Series Sweep Oscillator.....	62
8690-Series Sweep Oscillator.....	320
8705A Signal Multiplexer \$2075.....	327
8706A Control Unit \$650.....	327
8707A RF Unit Holder \$1525.....	327
8708A Synchronizer \$1950.....	294
8709A Synchronizer \$995.....	327
8717A Transistor Bias Supply \$1600.....	385, 73
8721A Directional Bridge \$150.....	74
8730-Series PIN Modulators.....	310
8740A Transmission Test Unit \$1500.....	383
8741A Reflection Test Unit \$1600.....	383
8742A Reflection Test Unit \$1700.....	383
8743A Reflection/Transmission Test Unit \$2550.....	384
8745A S-Parameter Test Set \$3150.....	384, 73
8746B S-Parameter Test Set \$5000.....	73
8747A Waveguide Test Set.....	384
8761A/B Coax Switch \$150.....	347
8801A Low Gain DC Amp \$295.....	136
8802A Medium Gain Amp \$325.....	136
8803A Low Level Preamp \$695.....	137
8805A Carrier Preamp \$425.....	137
8806B Phase Sensitive Demodulator \$525.....	138
8807A AC to DC Converter \$750.....	139
8808A Log Level Preamp \$625.....	139
8809A Signal Coupler \$125.....	138
8820A Bank Amplifier \$1250.....	141
8821A Bank Amplifier \$2500.....	141
8875A Differential Amplifier \$495.....	464
8900B Peak Power Calibrator \$725.....	391
8925A DME/ATC Test Set \$13,800.....	308

9000

9100A Programmable Calculator \$3950.....	82
9100B Programmable Calculator \$4900.....	82
9101A Extended Memory \$3690.....	34
9102A Buffer Box \$280.....	34
9120A Calculator Printer \$975.....	83
9125A Replaced by 9125B.....	
9125B Calculator Plotter \$2675.....	35
9150A Calculator Display \$975.....	85
9160A Optical Cardreader \$490.....	85
9500 Automatic Test System from \$50,000.....	90

00000-00610A

00103A Inductor, for 260A \$25.....	231
00127A Set of sixteen 00103A's, for 260A \$360.....	231
00128A Set of seventeen 00103A's, for 160A \$380.....	231
00513A Q Standard for 260A \$125.....	231, 59
00515A Coax Adapter Kit, for 250B \$75.....	228
00518A Q Standards for 260A \$125.....	231, 59
00538A Q Standards for 260A \$675.....	231
00564A Coupling Transformer, for 260A \$75.....	231
00590A Inductor, for 190A \$30.....	229
00591A Set of sixteen 00590A's for 190A \$130.....	229

MODEL NUMBER INDEX *continued*See 1971 Supplement for products with
blue page numbers; 1970 Catalog for others**00600A to 13065A**

00600A Probe Accessory Kit, for 4815A \$75.....	223
00601A Component Mounting Adapter, for 4815A \$25.....	223
00610A Terminal Shield, for 4800A \$15.....	222

10,000

10001A/B 10:1 Divider Probe \$35.....	536
10002A/B 50:1 Divider Probe \$40.....	536
10003A 10:1 Divider Probe \$35.....	536
10004A 10:1 Divider Probe \$40.....	536
10005A 10:1 Divider Probe \$40.....	536
10006A 10:1 Divider Probe \$40.....	536
10007A 1:1 Probe \$20.....	536
10008A 1:1 Probe \$20.....	536
10009A 10:1 Divider Probe for 191A \$60.....	537
10011A BNC Adapter Tip for 10004A-6A/12A \$8.....	535
10012A 10:1 Divider Probe \$40.....	536
10020A Divider Probe for 50 Ohm Inputs \$100.....	508, 534
10025A 1:1 Probe \$15.....	536
10036A Probe Tip Kit for 10004A-6A/12A \$20.....	535
10037A Probe Tip Kit for 10004A-6A/12A \$15.....	535
10100A 50 Ohm Feedthrough Termination \$15.....	535
10100B 100 Ohm Feedthrough Termination \$18.....	535
10110A Adapter Male BNC to Dual Banana Post \$7.....	283, 535
10010C BNC Probe Adapter Tip \$10.....	535
10035A Probe Tip Kit for 10001A-3A \$5.....	535
10111A Adapter, Female BNC to Shielded Banana Post \$10.....	283, 535
10112A BNC to Banana Adapters Obsolete	
10120A Cable Assembly BNC to BNC \$10.....	537
10121A Cable Assembly BNC to BNC \$10.....	537
10122A Cable Assembly BNC to Type N \$15.....	537
10123A Cable Assembly BNC to BNC \$14.....	537
10124A Cable Assembly BNC to BNC \$15.....	537
10127A Cable Assembly GR to BNC \$16.....	537
10128A Cable Assembly GR to BNC \$16.....	537
10164B Cover with Accessories for 1551A \$165.....	537
10166A Panel Cover for 180 Cabinet Models \$30.....	537
10167A Cover, Dust for 180 Cabinet Models \$25.....	537
10169A Panel Cover; 1200 Series Cabinet \$35.....	537
10175A Viewing Hood Polarized Round \$15.....	536
10175B Viewing Hood Round, Face Mask \$20.....	536
10176A Viewing Hood, Rect CRT \$10.....	536
10178A Contrast Filter, CRT 5" Grounding Tabs \$15.....	536
10179A Contrast Filter, CRT 5" \$7.....	536
10180A Contrast Filter, CRT 5" Round \$7.....	536
10181A Amber Filter for 1300A + 143A \$35.....	536
10182A Contrast Filter for 1300A + 143A.....	536
10214A 10:1 Divider Tip for 1410A Plug-In \$30.....	508
10215A 100:1 Divider for 1410A Probes \$50.....	508
10216A Isolator for 1410A Plug-In Probes \$25.....	508
10217A Blocking Capacitor for 1410A Plug-In \$20.....	508
10218A Probe Tip to BNC Adapter \$7.....	508
10219A Probe Tip to GR Adapter \$15.....	508
10220A Microdot Screw-On Adapter \$4.....	508
10221A 50 Ohm Tee Connector \$50.....	508
10352A Grafflok Back for 195A/197A \$85.....	542
10353A Polaroid Pack Back for 195A/197A \$95.....	542
10355A Bezel Adapter, Camera \$20.....	542
10356A Camera Bezel Adapter \$20.....	542
10357A Camera Bezel Adapter \$25.....	542

10358B Carrying Case for 195A, 197A, 198A \$80.....	542
10360A Camera Bezel Adapter \$20.....	542
10361A Camera Bezel Adapter \$20.....	542
10362A Camera Bezel Adapter \$20.....	542
10363A Camera Bezel Adapter \$20.....	542
10365A Roll Back for 195A/197A \$95.....	542
10406A Extender Cable for 140 Series Plug-Ins \$40.....	537
10407A Plug-In Extender for 180 Series \$75.....	537
10452A-10456A Rise Time Converter \$95.....	516
10457A Adapter 75 Ohm GR to Type N \$45.....	516
10458A Adapter 75 Ohm GR to Type F \$25.....	516
10477A Blank Plug-In for 140 Series \$30.....	536
10478A Blank Plug-In Double Size for 140 Series \$35.....	536
10479A Tilt Tray for 1119A or 1119B \$35.....	538
10479B Tilt Tray for 1119C and D \$35.....	538
10480A Storage Cabinet for 1119A \$45.....	538
10480B Storage Cabinet for 1119C \$45.....	538
10509A Loop Antenna \$380.....	626
10511A Spectrum Generator \$200.....	296
10512A Coax Lead-In Cable for 10509A \$30.....	626
10514-Series Double Balanced Mixers.....	235
10534-Series Double Balanced Mixers.....	235
10515A Frequency Doubler \$150.....	296
10525A Logic Probe \$95.....	40, 92
10528A Logic Clip \$125.....	40
10536A Counter Plug-In Adapter \$175.....	579
10538A Counter Fixed Program Shell \$190.....	579

11,000

11000A Cable Assembly \$6.....	196
11001A Cable Assembly \$7.....	196
11002A Test Leads \$8.....	196
11003A Test Leads \$10.....	196
11004A Line Matching Transformer \$65.....	283
11005A Line Matching Transformer \$85.....	283
11018A Adapter \$35.....	185
11021A Divider Probe for 425A \$55.....	191
11022A Probe Tip Pen for 411A \$25.....	187
11023A VHF Probe Tip for 411A \$35.....	187
11024A Type N "T" Probe Tip for 411A \$40.....	187
11025A Probe Tip for 411A \$18.....	187
11026A 100:1 Probe Tip for 411A \$40.....	187
11027A Probe Kit for 411A \$190.....	187
11028A 100:1 Current Divider for 456A \$60.....	195
11035A Cable Assembly \$7.....	196
11036A AC Probe for 410C \$70.....	185
11039A Capacitive Voltage Divider \$250.....	185
11040A Capacitive Voltage Divider \$40.....	185
11041A 100:1 Voltage Divider \$60.....	176
11042A Probe Coaxial "T" Connector \$60.....	185
11043A Probe Coaxial "N" Connector \$45.....	185
11044A 100:1 DC Voltage Divider for 410B \$50.....	185
11045A Capacitive Voltage Divider \$60.....	185
11046A Instrument Enclosures \$150.....	638
11048B 50-Ohm Feed-Thru \$10.....	283
11049A Thermal Converter \$125.....	165
11050A Thermal Converter \$125.....	165
11051A Thermal Converter \$125.....	165
11054A Input Cable Assembly for 740B \$50.....	162
11055B Output Cable Assembly for 740B \$65.....	162
11061A 10:1 Divider Tip for 3406A \$35.....	187



11063A	50-Ohm "T" for 3406A \$55	187
11064A	Accessory Probe Kit for 3406A \$115	187
11065A	Cable Assembly for 3460B, 3462A \$20	216
11071A	Accessory Probe Kit for 3406A \$200	187
11072A	Isolation Probe Tip for 3406A \$15	187
11073A	Pen Type Probe for 3406A \$45	187
11074A	Voltage Divider Probe \$75	177
11075A	Instrument Case 8" Deep \$60	639
11076A	Instrument Case 11" Deep \$60	639
11077A	Ohms Converter for 3450A \$425	211
11078A	AC Converter for 3450A \$1250	211
11079A	Limit Test Plug-In for 3450A \$375	211
11080A	Printer Output Plug-In for 3450A \$225	211
11085A	Remote Control Cable for 3460B, 3462A \$30	216
11086A	Cable Assembly \$7	196
11090A	Rear Input Cable for 3461A \$30	217
11091A	Rear Output Cable for 3460B, 3461A \$35	217
11092A	Interface Logic Cable for 3460B, 3461A \$40	217
11093A	Remote Control Cable for 3461A \$20	217
11094A	75-Ohm Feed-Thru \$10	283
11095A	600-Ohm Feed-Thru \$10	283
11096A	High Frequency Probe \$60	195
11097A	RF Detector for 675A \$30	317
11098A	Leveling Detector for 675A \$30	317
11099A	Remote Control Plug-In for 3450A \$260	211
11112A	Limit Selector for 3450A Opt. 003 \$175	211
11133A	Rear Input Cable for 3450A \$30	211
11135A	AC Power Pack for 204C/D \$60	276
11136A	Mercury Power Pack for 204C/D \$75	276
11137A	Rechargeable Battery Pack for 204C/D \$95	276
11138A	Impedance Adapter for 675A, 676A \$175	373
11146A	3480/Computer Interface Kit \$1000	57
11147A	Non-Isolated Digital Output for 3480A/B \$200	57
11148A	Extender Cable for Servicing 3480A/B Plug-Ins \$45	57
11149A	Remote Cable for 3480A/B Plug-Ins \$25	57
11151A	Isolated Remote Control for 3482A/3484A \$200	57
11152A	Ohms Converter for 3484A \$200	57
11153A	True RMS AC Converter for 3484A \$800	57
11300A	Single Frequency Marker for 675A \$75	317
11500A	RF Cable, Type N \$20	196
11501A	RF Cable, Type N \$20	196
11503A	Flexible Waveguide \$60	339
11504A	Flexible Waveguide \$50	338
11505A	Bench Stand for 297A \$25	458
11507A	Output Termination \$70	295
11509A	RF Fuseholder \$40	295
11511A	Short, Type N \$10	356
11512A	Short, Type N \$10	356
11515A	K-Band Flange Adapter \$60	340
11516A	R-Band Flange Adapter \$50	340
11517A	Waveguide Mixer \$200	414
11518A	Waveguide Adapter \$125	414
11519A	Waveguide Adapter \$125	414
11520A	Waveguide Adapter \$125	414
11521A	Waveguide Mixer \$75	414
11524A	Adapter, APC-7 to Type N \$70	355
11525A	Adapter, APC-7 to Type N \$70	355
11530A	Balanced Probe for 312A \$225	461
11531A	Test Unit for 8690B \$400	328
11533A	Adapter APC-7 to SMA \$115	355
11534A	Adapter, APC-7 to SMA \$115	355
11536A	50 Ohm Tee \$75	378

11539A	Reproduce Track Selector \$340	152
11540A	Waveguide Stand \$10	355
11541A - 11548A	Waveguide Clamps \$5 (Each)	355
11549A	Power Splitter \$85	378
11553A	Pack Sensor \$350	152
11565A	Short, APC-7 \$25	356
11570A	Accessory Kit for 8405A, \$340	378
11572	Digital Reel Hub Adapter \$17	152
11581A	Coax Attenuator Set \$250	343
11582A	Coax Attenuator Set \$310	343
11583A	Coax Attenuator Set \$575	343
11587A	Accessory Kit for 8410A \$975	384
11588A	Coax Rotary Joint \$200	347
11589A	Bias Network \$250	385
11590A	Bias Network \$300	385
11599A	Quick-Connect Adapter \$90	384
11600B	Transistor Fixture \$600	385, 73
11602B	Transistor Fixture \$600	385, 73
11604A	Universal Extension, for 8745A \$850	384
11605A	Flexible Arm, for 8743A \$700	384
11606A	Coax Rotary Air Line \$150	347
11607A	Small-Signal Adapter, for 8745A \$600	73
11608A	Transistor Fixture \$400	73
11650A	Accessory Kit, for 8410S \$725	384, 72
11652A	Reflection-Transmission Kit, for 8407A \$325	374, 74
11654A	Passive Probe Kit, for 8407A \$325	374
11655A	Impedance Probe, for 8407A \$750	74
11663A	Counter Mod Kit, for 8443B \$1525	78

12,000

12539A	Time Base Generator \$1000	71
12540A	Data Phone Interface Obsolete	
12551B	Relay Output Register \$600	71
12554A	16-Bit Duplex Register \$750	71
12555A	D-A Converter \$1000	71
12564A	A to D Converter \$1250	103
12566A	Microcircuit Interface \$750	71
12597A	8-Bit Duplex Register \$600	71
12670A	Containing Case for 2471A \$900	466
12797A	BCD Input for 2570A \$600	43
12798A	BCD Output for 2570A \$500	43
12799A	16-Bit Relay Register for 2570A \$500	43
12800A	8-Bit Duplex Register for 2570A \$500	43
12801A	Teleprinter Interface for 2570A \$450	43
12802A	Calculator Interface for 2570A \$1775	43
12803A	Ten-Channel Scanner for 2570A \$600	43
12804A	Diagnostic Control Panel for 2570A \$400	43
12805A	I/O Card Extender for 2570A \$75	43
12806A	Control Card Extender for 2570A \$75	43
12807A	Pinboard Program Card for 2570A	43
12809A	Time-Sharing Interface for 2570A \$1500	43

13,000

13060A	Remote Start/Stop Switch \$40	151
13061A	DC-AC Inverter (12 VDC) \$190	151, 50
13061B	DC-AC Inverter (28 VDC) \$190	50
13062A	Loop Adapter \$370	50
13603A	Voice Channel \$190	151
13065A	Rack Mount Kit \$21	151

MODEL NUMBER INDEX *continued***13066A to 80511P**See 1971 Supplement for products with
blue page numbers; 1970 Catalog for others

13066A Transit Case \$375.....	151
13068A,B Rack Slide Mounting Kit \$165.....	50
13181A Interface Kit \$4600.....	39
13190A Multi-Unit Cable \$175.....	39
13191A Control and Status Test Board \$250.....	39
13192A Write Test Board \$250.....	39
13193A Read Test Board \$250.....	39
13510A Transistor Test Jig, for 250B \$250.....	228
13515A Frequency Doubler Probe, for 3200B \$95.....	289
13525A Calibration Resistor, for 4800A \$10.....	222

15,000

15108B Microphone Preamplifier \$175.....	60
15109B Condenser Microphone Assy. \$330.....	60
15114A Microphone Power Supply \$165.....	61
15117A Sound Level Calibrator \$285.....	61
15118A Preamplifier \$175.....	60
15119A Condenser Microphone Assy. \$330.....	60
15124A Insert Voltage Adapter \$60.....	61
15125A Insert Voltage Adapter \$60.....	61
15127A Cable Amplifier \$105.....	60
15134A Capacitive Termination \$35.....	61
15142A Capacitive Termination \$35.....	61
15170A Piezoelectric Accelerometer \$180.....	60
15526A Accessory Kit for 3701A/2A/3A \$150.....	446

16,000

16005A Probe for 4328A (Clip On) \$30.....	192
16006A Probe for 4328A (Pin-Contact) \$14.....	192
16007A Test Leads \$9.....	192
16008A Resistivity Cell \$200.....	193
16009A Transistor Socket Kit for 4470B \$75.....	77
16014A Series Loss Test Adaptor for 4342A \$35.....	59
16117A Low Noise Test Leads for 4329A.....	193
16462A Auxiliary Capacitor for 4342A \$150.....	59
16465A Reference Inductor for 4342A \$25.....	59
16470A Set of 20 Reference Inductors for 4342A \$500.....	59
16471A-16490A Reference Inductors for 4342A \$25.....	59

17,000

17005A Incremental Chart Advance \$995.....	120
17006A Manual Chart Advance \$125.....	120
17009B Character Printer \$95.....	120
17012 Point Plotter \$95.....	119
17108A Time Base \$175.....	120
17170A DC Coupler \$25.....	118
17171A DC Amplifier \$275.....	118
17172A Time Base \$200.....	118
17173A Null Detector \$225.....	118
17174B DC Offset \$100.....	119
17175A Filter \$75.....	119
17176A Scanner \$325.....	119
17177A AC-DC Converter \$500.....	47
17178A DC Attenuator \$100.....	119
17500A Input Span Module \$250.....	125

17501A Input Span Module \$350.....	125
17502A Temperature Module \$375.....	125
17503A GC Module \$250.....	125
17504A Single Span Module \$200.....	125
17505A High Sensitivity Module \$400.....	47

30,000

33300 Series Programmable Step Attenuators.....	69
---	-----------

60,000

60063A Obsolete.....	
60063B DC Power Supply, Slot \$87.....	566
60065A DC Power Supply, Slot \$110.....	566
60066A DC Power Supply, Slot \$197.....	566
60122B CD Power Supply, Slot \$72.....	566
60123B DC Power Supply, Slot \$79.....	566
60125B DC Power Supply, Slot \$100.....	566
60126B DC Power Supply, Slot \$179.....	566
60153D Dual Slot Power Supply \$97.....	567
60155C Dual Slot Power Supply \$133.....	567
60242B DC Power Supply, Slot \$72.....	566
60243B DC Power Supply, Slot \$79.....	566
60244B DC Power Supply, Slot \$88.....	566
60245B DC Power Supply, Slot \$100.....	566
60245B DC Power Supply, Slot \$179.....	566
80511P Sound Level Recorder \$2,270.....	49

A BRIEF SKETCH



ABOUT HEWLETT-PACKARD

Hewlett-Packard is a major designer and manufacturer of electronic, medical, analytical, and computing instruments and systems. From its founding in 1939, the company has conscientiously followed its basic philosophy of offering only products representing significant advances in measurement technology. The company's first instrument—an economically priced audio oscillator far more stable and easier to use than any such instrument available at the time—met this demanding criterion, as have the many HP products that have followed.

The company manufactures more than 2,000 products, most of which fall into the category of electronic test and measurement equipment. This includes many of the "work-horse" products such as oscillators, voltmeters, oscilloscopes, counters, and microwave equipment, as well as a variety of instruments and systems for specialized applications.

However, the company has also entered several additional and important new product areas over the course of the years, and today the company name is seen on instruments and systems for medical diagnosis and monitoring, on others for biophysical and chemical measurement and analysis, and on an impressive selection of solid-state devices.

The increasing need to automate the testing of electronic components, equipment, and systems led Hewlett-Packard, in recent years, into the field of computational equipment. In addition to developing a family of computers, and electronic calculator systems, the company is also applying its computer design technology to an increasing number of its test and measuring instruments. Complementing HP's computer and calculator hardware is an extensive library of software for programming purposes.

To maintain its leadership in instrument technology, Hewlett-Packard invests heavily in new product development. Research and development expenditures traditionally average about 10 percent of sales revenue, and some 1,500 engineers and scientists are assigned the responsibilities of carrying out the company's various R&D projects. As a result of this effort, about half of the company's current business is represented by products that were not in existence six years ago.

The company has also shown leadership in manufacturing techniques, developing many innovations that make it possible to offer high quality products at moderate cost. Engineering

and production of solid-state devices, integrated circuits, and hybrid microcircuitry are prime examples; others include quartz resonators, cathode-ray tubes, transformers, and panel meters. In many cases, specialized equipment is required for the production of these components as well as other unique parts. Often this equipment is designed and built in-house either because it is not available on the outside, or because it allows HP an extra measure of control in maintaining the quality and performance expected of its products.

Hewlett-Packard is a well-established, multi-national company that has controlled its growth so that expansion is financed generally from income on a pay-as-you-go basis. From its modest beginnings in Palo Alto, California, the company now has nine manufacturing plants in California, two in Colorado, two in New Jersey, one in Pennsylvania, and one in Massachusetts. HP's overseas manufacturing facilities are located in Scotland, West Germany, Japan, and Singapore.

However, for the customer, HP is no farther away than the nearest telephone. There are more than 50 field offices in the United States, and the company's products are marketed in over 100 countries abroad. All of these offices offer immediate assistance in solving measurement problems and providing advice on equipment selection, or with any help needed to keep equipment already in service in first-class operating condition. The field offices are staffed by trained engineers, each of whom has the primary responsibility of providing technical assistance and data to customers. A vast communications network has been established to link each field office with the factories and with corporate offices. No matter what the product or the request, a customer can be accommodated by a single contact with the company.

Hewlett-Packard is guided by a set of written objectives. One of these is "to provide products and services of the greatest possible value to our customers." Through application of advanced technology, efficient manufacturing, and imaginative marketing, it is the customer that the more than 16,000 HP people strive to serve. Every effort is made to anticipate customer's needs, to provide products that will enable him to operate more efficiently, to offer him the kind of service and reliability that will merit his highest confidence, and to provide all of this at a reasonable price.

Hewlett-Packard Corporate Headquarters, Palo Alto, Calif.

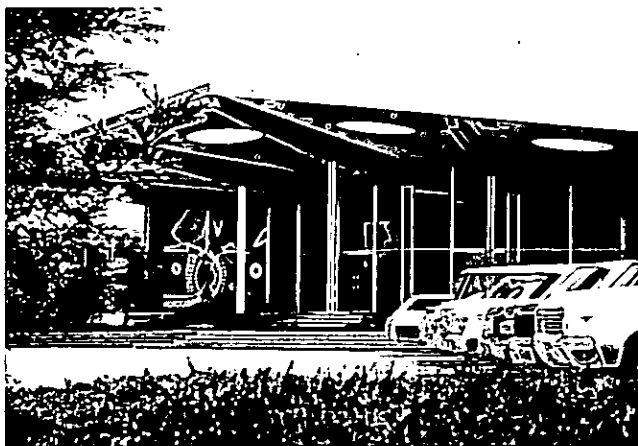

Microwave, and Corporate Headquarters, Palo Alto, Calif.



SERVICES



TECHNICAL PUBLICATIONS AND PERIODICALS

Technical Publications And Periodicals

An expanding technology demands ever increasing levels of measurement sophistication. To help keep customers informed of new instruments and new measurement techniques, Hewlett-Packard has available a variety of publications.

Hewlett-Packard Journal

In-depth discussions of important new Hewlett-Packard products, written by the engineers who developed them, are published in the Hewlett-Packard Journal. This monthly publication is devoted to detailed academic discussions of new approaches to measurement and computation, of the most productive methods of using instruments and components, and of the latest equipment for both complex and routine measurements.

Measurement News

New Hewlett-Packard products are described concisely in Measurement News, a bimonthly publication that is printed in six languages. This publication carries announcements about newly available products, about Application Notes, and, very often, it has announcements of local interest from your nearby Hewlett-Packard field office. A convenient postpaid Reader's Service Card accompanying each issue brings you any of the described Application Notes or detailed specifications of the new products outlined in Measurement News.

Analytical Advances

Analytical measurement techniques for the chemist are described in Analytical Advances. This publication, besides discussing new engineering developments, reports new findings from the Hewlett-Packard chemical applications laboratories.

Molecules And Microwaves

New developments and findings in microwave spectrometry (molecular rotational resonance) are described in Molecules and Microwaves. This publication is issued periodically to describe new instruments and techniques for this growing technology.

Measuring For Medicine And The Life Sciences

Techniques and results of applying new measurement methods in the life sciences are described in Measuring for Medicine and the Life Sciences. This is a quarterly publication produced by the biomedical technical staff at Hewlett-Packard's Medical Electronics Division.

Data Sheets

Technical data sheets are prepared for each Hewlett-Packard product or family of related products. These list performance specifications, capabilities, power consumption, dimensions, prices, and the various options and accessories that may be available, essentially the same information given in this catalog. If you want separate copies of the complete technical description of any Hewlett-Packard product, ask for the data sheet by number.

Application Notes

Application Notes that describe a wide variety of uses for electronic instruments and components are prepared by the Hewlett-Packard engineering laboratories. Because of the specialized nature of these publications, they are distributed by individual request only, rather than by general mailings. Brief summaries of all available Application Notes are contained in an Application Note Index, yours for the asking.

If you would like to receive any of these company-produced periodicals on a regular basis, or obtain any of the application notes, you can do so by contacting your Hewlett-Packard field engineer, or by writing Hewlett-Packard, 1501 Page Mill Road, Palo Alto, California 94304.

WHAT YOU CAN EXPECT WITH YOUR H. P. EQUIPMENT



SERVICES

SERVICE AGREEMENTS, PARTS PUBLICATIONS, REPAIRS

When you purchase equipment from Hewlett-Packard, you get more than a piece of hardware—you get long-term measurement, analysis, or computation capability far more valuable than the worth of the knobs, connectors, wires and electronic components that make up the product. First of all, Hewlett-Packard certifies traceability at specified accuracy levels to the U.S. National Bureau of Standards. You may be sure that your equipment will meet its published specifications when you get it. Furthermore, you have a warranty on materials and workmanship.

Your purchase also includes applications assistance that helps you get maximum value from your equipment, first by means of the instruction manuals supplied with each Hewlett-Packard product, and then with the many available Hewlett-Packard Application Notes and other user-oriented publications. Also, there are application-oriented training seminars

that give hands-on experience with many types of equipment.

Assurance that your equipment will continue to perform as expected for years to come is provided by Hewlett-Packard's world-wide Customer Service organization. There is a Hewlett-Packard field office not far from you—you don't have to correspond with a factory several thousand miles away to get information, replacements parts, or service assistance when you need it. This customer service program is one of the major factors in Hewlett-Packard's reputation for integrity and responsibility towards its customers.

Service information is included in the operating manual supplied with each product. Also available are service-oriented seminars for giving your own service technicians first-hand experience and training in the maintenance of Hewlett-Packard products.

WARRANTY—CERTIFICATION

Warranty

All Hewlett-Packard products are warranted against defects in materials and workmanship. The period of coverage is specified in the Operating and Service Manuals provided with each product. We will repair or replace, at our option, products which prove to be defective during the warranty period.

This statement is an expression of confidence in the ability of Hewlett-Packard products to continue meeting the high standards of reliability and performance that engineers and scientists have learned to expect from Hewlett-Packard.

To be attained, high quality requires more than stringent test procedures—quality must be designed into a product from its very inception. Hewlett-Packard engineers make every effort to arrive at a design that achieves quality and long-term reliability. Component engineers help the designers select components that can be relied upon, and make sure that components are not subject to undue electrical, thermal, or mechanical stress. Product engineers on the design team develop a rugged, easily produced mechanical design, and industrial designers, besides contributing to a pleasing appearance, make sure that human factors are considered. Packaging engineers are consulted to anticipate any difficulties that the product otherwise might experience during its trip from factory to customer. Environmental engineers subject prototype products to vibration, shock, humidity, and temperature extremes to assure that they can function in expected environments. Manufacturing know-how developed over the years

gets the products assembled right. This statement can then accompany each order:

Certification

Products, materials, parts, and services furnished on this order have been provided in accordance with all applicable Hewlett-Packard specifications. Actual inspection and test data pertaining to this order is on file and available for examination.

Hewlett-Packard's calibration measurements are traceable to the National Bureau of Standards to the extent allowed by the Bureau's calibration facilities.

The Hewlett-Packard Quality Program satisfies the requirements of MIL-Q-9858, MIL-I-45208, and MIL-C-45662.

As a further check, products are picked at random off the assembly line and subjected to a quality audit by a "third party" quality assurance group. The result of all these efforts is that users of measuring instruments have found that they can rely on Hewlett-Packard products. This customer confidence has helped build Hewlett-Packard into one of the world's foremost manufacturers of instruments for measurement, analysis, and computation.



SERVICE PUBLICATIONS

Operating and Service Manuals

The Operating and Service Manual that accompanies each Hewlett-Packard product is complete enough that any technically qualified person should be able to operate the equipment without additional instruction. In addition, the Manual describes the various tasks the equipment can perform, how to use the equipment, and what precautions, if any, should be observed.

The manual also contains maintenance and calibration procedures. Diagnostics and repair procedures are also included, many with trouble-shooting charts as well as complete circuit diagrams. All replaceable parts are listed.

One manual (or set of manuals) is supplied with each product. Extra manuals, for many older instruments as well as for all currently-produced products, are available at reasonable cost from your nearby Hewlett-Packard field office.

Service Notes

New or special calibration procedures, instrument modifications, and special repair procedures are described in detail

in the Hewlett-Packard Service Notes. This series of publications, intended primarily to disseminate repair and maintenance information on Hewlett-Packard instruments, serves as a convenient means for updating customers' Operating and Service Manuals. Ask your local Hewlett-Packard field office for a copy of the Service Note Index so you can order the service notes that pertain to your instruments.

Bench Briefs

This periodic newsletter has servicing tips, new modifications, and other suggestions to help repair and maintenance personnel get maximum performance from the Hewlett-Packard instruments for which they are responsible. It also describes new Service Notes and other company publications as they become available. To become a regular subscriber, merely ask your local Hewlett-Packard field office to place your name on the mailing list.

REPAIR SERVICE

Help in maintaining your Hewlett-Packard equipment in first-rate operating condition is as close as a phone call to the nearest Hewlett-Packard field office. Whether you want to repair an instrument yourself, or send it to a Hewlett-Packard facility for repair, recalibration, or overhaul, your local Hewlett-Packard field office can offer a complete range of technical assistance.

Hewlett-Packard believes that as a manufacturer of measuring instruments it has an obligation to help each user get maximum usefulness from his Hewlett-Packard products. To this end, most Hewlett-Packard field offices have customer service facilities for providing repair and maintenance at a fair price. These are staffed by factory-trained technicians equipped with the needed test instruments and replacement parts. Local repair facilities are backed up by Regional Repair Centers, located in major industrial areas around the world. The Regional Repair Centers have more sophisticated test

equipment, factory-trained specialists, and a full line of replacement parts.

Customer services range from simple calibrations to complete restoration of a product to good-as-new condition. Older products can often be modified to match the performance of current production models.

If your equipment installation is fixed, and if justified by the type of service required, Hewlett-Packard will perform service at your facility. Bringing your equipment to the Hewlett-Packard field office is preferred, however, because replacement parts and the needed test equipment are more readily available.

All service facilities have direct access to service engineers within each of Hewlett-Packard's manufacturing divisions. You have access to all of Hewlett-Packard's extensive service network through your local Hewlett-Packard field office.

WHAT YOU CAN EXPECT WITH YOUR H. P. EQUIPMENT



SERVICES

CUSTOMER SERVICE AGREEMENTS

Your instrument maintenance needs in many cases may be handled most economically by entering into a Hewlett-Packard Customer Service Agreement. When you have a customer service agreement, Hewlett-Packard assumes your maintenance responsibilities for a basic annual charge, relieving you of the need for hiring your own trained specialists, for maintaining replacement parts inventories, and for doing the paperwork needed for maintenance scheduling.

Each agreement is shaped to fit individual customer requirements. Depending on the services chosen, Hewlett-Packard performs regularly scheduled and fully documented maintenance and calibration, makes emergency repair service calls, and replaces worn or defective parts. Other options include operator training, standby instruments, exchange parts or

modules, and 24-hour availability of service or an agreed-upon response time.

Work can be performed on your premises or arrangements can be made for delivery of equipment to and from Hewlett-Packard facilities. If you have a large equipment inventory, you may include in your service agreement provisions for a resident Hewlett-Packard service technician stationed on your premises.

The cost of an agreement is derived from analysis of the service and repair history that Hewlett-Packard has collected on each product. By taking advantage of this information, Hewlett-Packard can assure you of continued accuracy and reliability of your equipment at a fair price, with minimum interruption for repair. Contact your nearby Hewlett-Packard field office for details.

REPLACEMENT PARTS

Ready availability of replacement parts is essential for prompt equipment maintenance-time spent waiting for parts is wasted time. Hewlett-Packard makes every effort to shorten spare parts delivery time and as a result, over 90% of the replacement parts orders are filled the same day they are received. If the field office does not have the needed part, the order is relayed to a regional center. No time is lost since a computerized data communication system links all field offices to the regional centers. Shipment of a relayed order is made directly from the regional center to the customer.

Spare Parts Kits

To sustain equipment operation in remote areas, or where equipment down-time is extremely critical, spare parts kits are available. The kits are supplied in varying degrees of completeness, allowing you a selection for a better match to your requirements. For information, contact your nearby Hewlett-Packard office.

Modification Kits

Modification kits, for updating the performance of older products, may be ordered from your nearby Hewlett-Packard

field office. These include the necessary parts and full instructions for installation, if you want to do the work yourself. If you prefer, your Hewlett-Packard field office can do the work for you at a reasonable price. Newly available modification kits are announced in Bench Briefs (page 28).

Parts Identification

The table of replacement parts in each Operating and Service manual makes it easy for you to identify parts you wish to replace. When ordering a replacement part, please specify the Hewlett-Packard part number listed in the table and give the complete name. If you have trouble identifying a part, be sure to call your local Hewlett-Packard field office. Each field office maintains extensive technical files on all Hewlett-Packard products.

If circumstances require your ordering a part without specifying the part number, please include in your order the instrument model number, its serial number, a complete description of the part, its function, and its location in the equipment.

SERVICES



TECHNICAL TRAINING

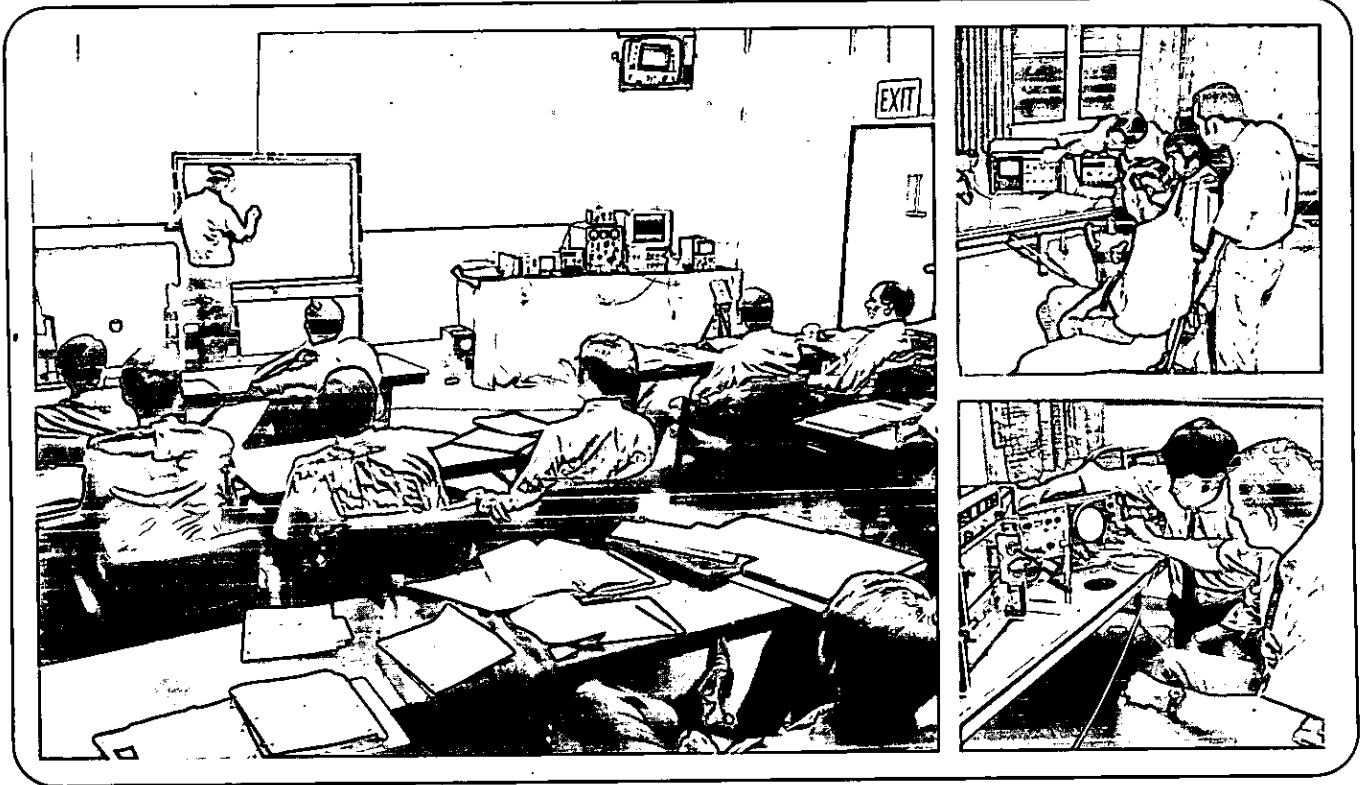

SEMINAR SUBJECTS		SEMINAR LOCATIONS		VIDEO TAPES
Applications. How to Use Instruments	Service. How to Repair HP Instruments	At Your Local HP Field Sales Office	At HP Training Facilities	Subjects Include Applications and Service of Instruments and General Electronic Theory

**CONTACT YOUR LOCAL HP FIELD SALES OFFICE
FOR SEMINAR AND VIDEO TAPE INFORMATION.**

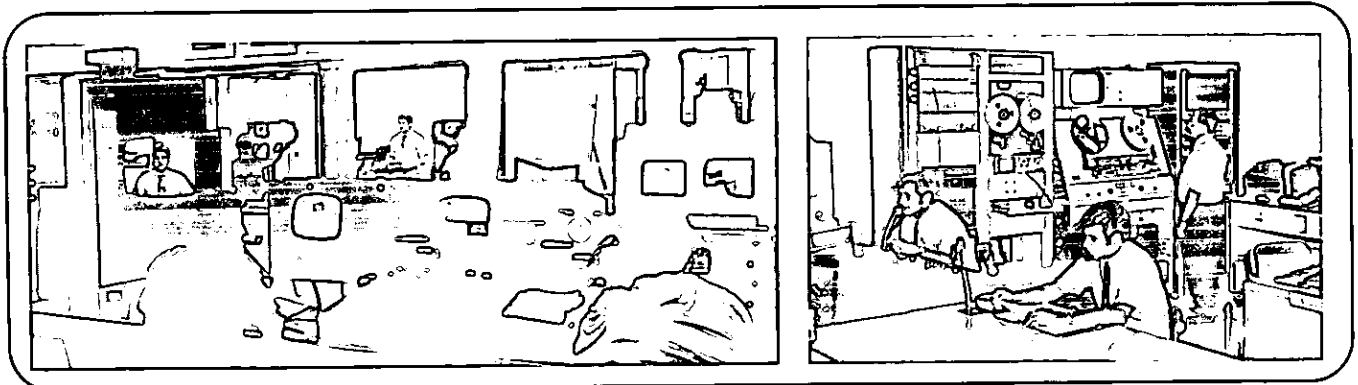

LASER INTERFEROMETER

Operational Simplicity with 1 μ in Resolution
Model 5525A



DIMENSIONAL METROLOGY

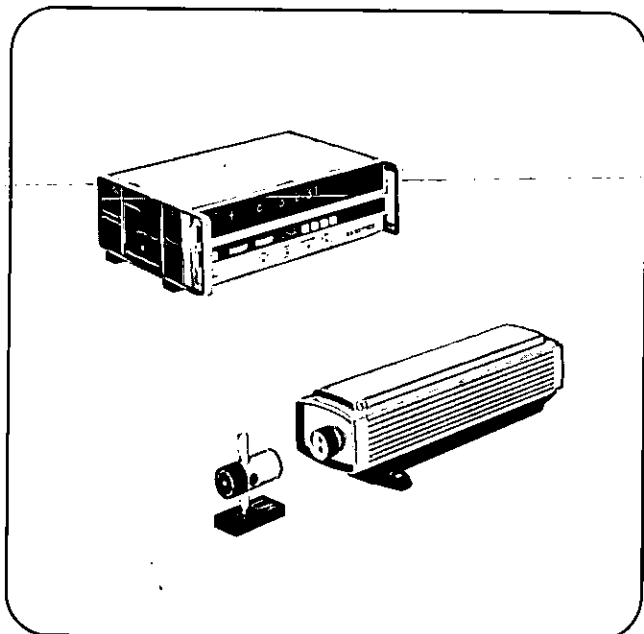

General Description

The Model 5525A Laser Interferometer is a highly precise linear distance measuring instrument. It measures and displays distance or velocity to a resolution of 1 microinch and .01 in/min respectively. The laser and interferometer optics are mounted on a rigid, 3-point mounted base, while the counting, computing and display electronics are contained in a separate unit. A retroreflector completes the 5525A system.

Features

Set-up and operation is simple. The 5525A is ready for use the instant it is switched on; tuning is automatic. A unique principle of optical heterodyning, using a specially designed Zeeman split laser, mixes two slightly different optical frequencies to give a frequency which can be counted using known counting techniques. This makes possible an a-c system which is vastly superior to d-c systems used in other laser interferometers, especially in adverse operating environments.

There are four modes of operation. NORMAL mode resolution is 10 microinches or 0.1 microns. The SMOOTH mode displays to the same resolution but eliminates jitter by smoothing vibration with digital low-pass filtering. In the third mode, X10, resolution is extended to 1 microinch or 0.01 microns. An internal time reference is included for velocity measurement up to 720 in/min or 300mm/s and is selected by the fourth mode button.

Other features include BCD output, programmability, simple circuit check buttons, English or metric readout, and manual and optional automatic compensation.

Applications

Equally suitable for shop and laboratory the 5525A offers significant benefits wherever there is a need for accurate, rapid measurement of distance or velocity. In the manufacture of integrated circuits the 5525A can be applied to mask-making, step and repeat cameras and other precision positioning opera-

tions. Machine-tool and metalworking industry applications include transducer and machine tool calibration, and parts inspection. In addition it can be built into machine tools or measuring machines as the distance transducer. A rear panel connector provides digital signals for closed-loop operation.

Options

Optional error-plotting provides a graph in real time of position error versus desired position, offering major time-savings in the calibration and evaluation of machines and positioning systems.

The Automatic Compensator eliminates the need for operator attention to the environment by correcting automatically for changes in air density and part temperature effects. Other options include a 90° Beam Bender and a Digital Recorder.

Specifications

- Accuracy:** 5 parts in 10^7 , ± 1 count
Resolution: (English or Metric units selected by front panel switch)
Normal and Smooth modes: 0.000, 01in (0.1 microns)
X10 mode: 0.000,001in (0.01 microns)
Velocity: 0.000,1in/sec; 0.01in/min (0.001mm/sec; 0.1mm/min)
Max. Operating Range:
Distance: 200 feet (60m)
Velocity: 720 in/min (300mm/s)
Outputs: BCD for printer, computer, etc. Incremental analog for plotter with optional Error Plotting board.
Power Requirements: 115 or 230 V $\pm 10\%$; 50 to 60 Hz.
Power Consumption: 150 watts
Overall Dimensions:
Display: 5.53 in. high x 16.75 in. wide x 13.25 in. deep (141 mm x 436 mm x 337 mm).
Interferometer Head: 5.00 in. high x 7.00 in. wide x 20.70 in. long (127 mm x 178 mm x 526 mm).
Weight:
Display: Net 24 lb (10.9 kg.), shipping 27 lb.
Interferometer Head and Retroreflector: Net 19.5 lb. (8.94 kg.), shipping 36.5 lb.

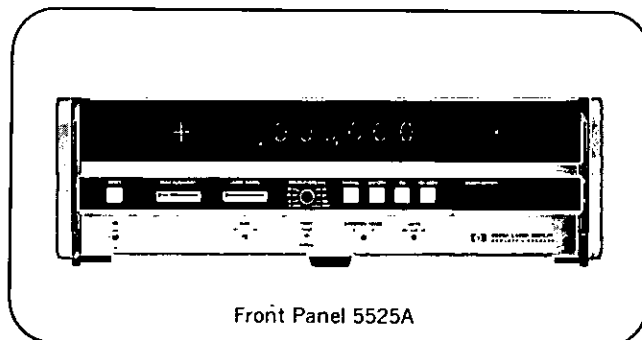

Front Panel 5525A

Price:		
5525A	Laser Interferometer	\$11,500
Opt. 010	Error Plotting Board	add 700
Opt. 011	Error Plotting System (includes 7035B X-Y Recorder)	add 1,685
Opt. 020	5525A Digital Recorder	add 1,200
Opt. 030	Automatic Compensator	*
Opt. 040	90° Beam Bender	add 595

*Contact nearest HP Sales Office, price to be announced.



RADIANT FLUX METER AND DETECTOR

Measure optical power with confidence
Model 8330A, 8334A

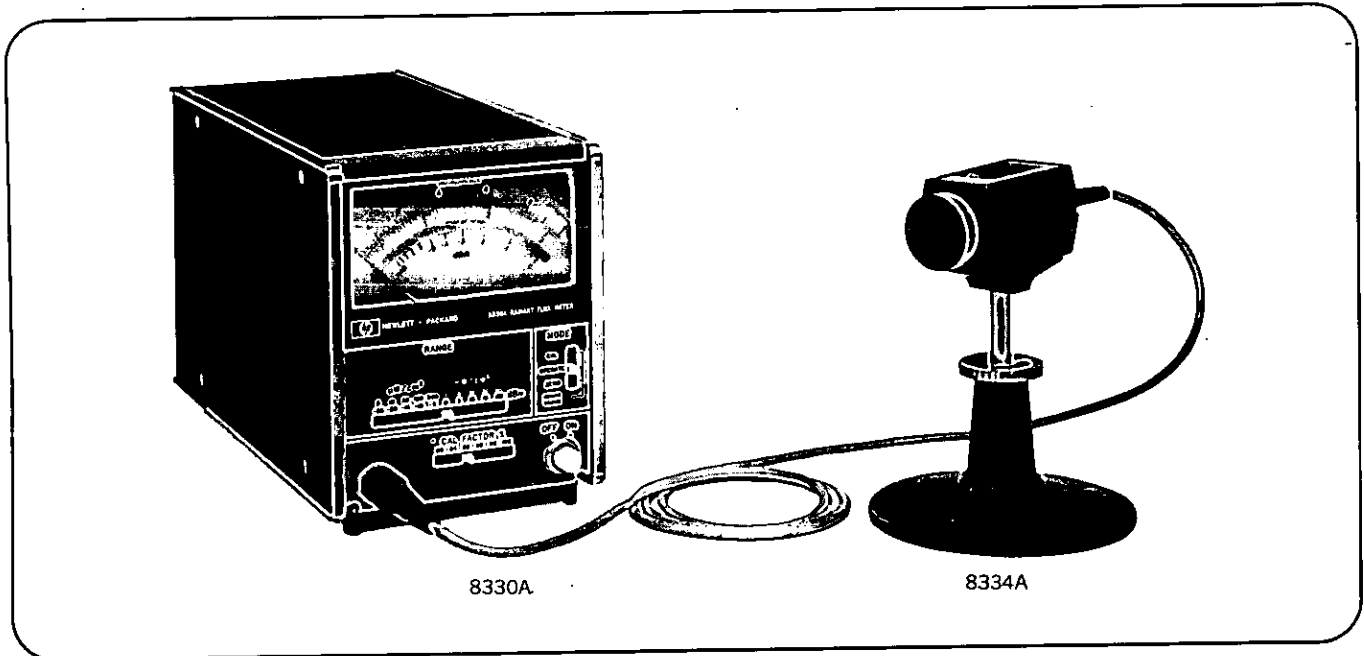

Description

The 8330A Radiant Flux Meter and 8334A Radiant Flux Detector combine to form a multipurpose optical power meter system for measuring total radiant power in the ultraviolet, visible and infrared with exceptional accuracy and unprecedented ease. Rapid, convenient and dependable measurements can be made either in specific wavelength intervals or over a continuous spectrum.

Direct Readout in Absolute Units

The system is fully calibrated and reads directly in absolute radiometric units at any wavelength. No spectral calibration charts are needed. Radiometric units are independent of wavelength and are therefore equally applicable in the ultraviolet, visible and infrared. Measurements made at one wavelength can be directly compared to measurements made at any other wavelength. Three frequently used radiometric quantities are measured by the 8330A/8334A system and are described below.

Quantity	Units	Measurement Conditions
Radiant flux	Watts	Input beam no larger than detector area (0.4 cm square)
Irradiance	Watts/cm ²	Total detector area irradiated
Radiance	Watts/cm ² /steradian	Total detector area irradiated and entire detector field-of-view (0.1 steradian) filled

Thin-Film Optical Detector

Key to the outstanding measuring capabilities of the complete system is the unique design of the HP-developed thin-film thermopile detector. This precision detector exhibits a combination of flat response, broad spectral coverage, rapid rise time and mechanical ruggedness not found in conventional designs.

The detector consists of 64 microminiature thin-film thermocouple junctions vacuum deposited on a single etched substrate. In operation, an optical coating, the characteristics of which are carefully controlled during manufacture, absorbs incident optical power over a wide range of wavelengths extending from the vacuum ultraviolet to the far infrared. The resulting minute temperature rise of the thermocouple junctions is monitored by measuring the resulting thermoelectric voltage. This output voltage is proportional to the optical input power dissipated within the detector. The ultra-low thermal mass of the thin-film elements and etched substrate enable the measuring junctions to heat and cool rapidly, resulting in rapid response to optical inputs. The reference junctions are held at the ambient temperature of a thermal heat sink, insuring low drift. Each of the 64 thermocouple junctions is connected in series, resulting in high sensitivity and resolution.

The standard detector is equipped with a quartz optical window. Other optical window materials, customer selected to cover certain spectral ranges, can be incorporated into the detector assembly during manufacture. Windowless detectors can also be provided for special applications.

Single element of thin-film detector

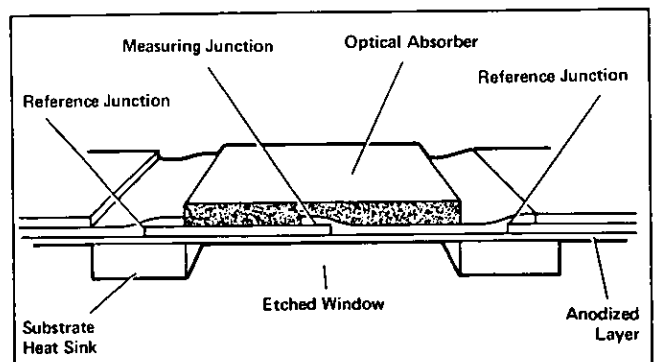

Automatic Calibration

A convenient method of periodic system calibration is essential since in practice all optical detectors, regardless of type, tend to change sensitivity with temperature, overload, mechanical shock and aging. Conventional optical power meters require frequent, time-consuming recalibrations to correct for the continual changes in sensitivity that are a result of normal usage.

The HP 8330A/8334A system incorporates a built-in, substitution-type automatic calibrator. With the quick push of a front panel switch, the circuit shown below automatically adjusts overall system gain to precisely match the sensitivity of the particular detector in use, regardless of detector temperature or aging.

In operation, an accurately known amount of low frequency (10 KHz) power from an internal oscillator is electrically injected into the detector. The resulting output voltage is amplified and compared to a reference. Any difference appears as a correction signal which compensates instrument gain. Furthermore, the ratio of low frequency power to optical power required for equal output voltage is measured at the time of manufacture. This numerical constant, called Calibration Factor, is imprinted on each individual detector and is quickly accounted for by use of the front panel CAL FACTOR control that correctly normalizes the meter reading.

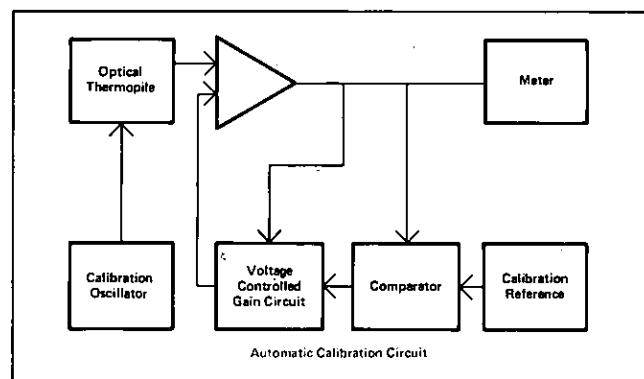

Built-in Calibrator Circuit

NBS traceable

Complete systems are carefully tested and calibrated in Hewlett-Packard's modern optical laboratories using NBS-traceable optical standards.

Automatic Meter Zero

The meter can be automatically zeroed in a few seconds to either ambient or zero input by simply depressing a front panel switch. Thus, if desired, the user can automatically cancel effects of background radiation or ambient illumination.

Convenient to use

Telescopes, microscopes, fiber optic probes and other accessories can be easily attached to the detector input. The lightweight probe is equipped with standard camera threads and can be mounted on the adjustable base supplied or on an optical bench.

Applications

The 8330A/8334A system is useful in a wide range of laboratory and industrial applications in a number of different fields such as optics, process control, analytical chemistry and many more.

Optical: Measurement of output from lasers*, gas-discharge devices, incandescent sources, CRT's, light-emitting diodes, monochromators and infrared sources; comparison of emissions at different wavelengths, precision calibration of detectors, photographic and holographic exposure levels, transmission and reflection characteristics of filters, lenses, mirrors, thin-films, liquids and gases.

Analytical and Process Control: Non-contact, remote temperature measurement, ambient illumination and sunlight level measurement, wideband detection in optical spectroscopy systems, photosynthesis research, colorimetry, and monitoring of UV photoresist exposures used in manufacture of printed circuits, microcircuits, and chemically-milled components.

*laser beams smaller than 3 mm in diameter or with power densities > 100 mW/cm² should be diffused

System specifications, 8330A/8334A

Dynamic measurement range: Radiant optical power measured in 10 full scale ranges (1:3:10 sequence) in units of:

Irradiance: 3 $\mu\text{W}/\text{cm}^2$ to 100 mW/cm^2 full scale.

Radiant Flux: 300 nW to 10 mW full scale.

Radiance: 300 $\text{nW}/\text{cm}^2/\text{sr}$ to 10 $\text{mW}/\text{cm}^2/\text{sr}$ full scale.

Resolution: better than 100 nW/cm^2 , 10 nW, or 10 $\text{nW}/\text{cm}^2/\text{sr}$.

Accuracy: System measurement uncertainty of irradiance is less than $\pm 5\%$ of full scale on any range. Traceable to NBS.

Spectral response: Standard detector, equipped with quartz optical window, responds from 0.3 to 3.0 microns, flat to within $\pm 3\%$ or less (typically $\pm 1\%$). Usable for relative measurements (not absolutely calibrated) from 0.2 to 4.0 microns. Spectral response is extendable from below 0.2 micron to above 15 microns with appropriate optical window materials. Accessory filters permit narrowband measurements.

Response time, 10-90%: Measured at recorder/DVM output is: < 70 ms on 1, 3, 10, 30, 100 mW/cm^2 ranges; < 0.7 sec on 30, 100, 300 $\mu\text{W}/\text{cm}^2$ ranges; < 2.7 seconds on 3 and 10 $\mu\text{W}/\text{cm}^2$ ranges. Detector element only: < 10 ms.

RMS noise: < 2% of full scale on bottom range, decreasing on all higher ranges.

Zero drift: < 1.0 $\mu\text{W}/\text{cm}^2/\text{hr}$ at reasonably constant ambient temperature. Automatic meter zero operates so rapidly and

conveniently that, if desired, meter can be zeroed before each reading to eliminate drift on most sensitive ranges.

Detector clear field-of-view: 0.1 steradian solid angle.

Active detector area (absorbing area): 0.1 cm^2

Calibration Factor control: Normalizes meter reading to account for Calibration Factor of particular probe in use. Can be used to compensate meter reading for known transmission losses of elements, such as filters, located in the optical path. 11 positions, 2% steps.

Filter compartment: Holds 3/4" round filters at detector cavity temperature to eliminate background radiation.

Maximum input without damage: 1.0 watt/cm^2 .

Recorder/DVM output: Voltage proportional to meter reading, 1.000 volt full scale. BNC connector on rear panel.

Power requirements: 115 or 230 VAC $\pm 10\%$, 50 to 400 Hz. 2-1/2 watts.

Weight: 8330A: net, 6 lb 15 oz (3.2 kg). Shipping 9 lb 14 oz (4.6 kg) 8334A: net, 1 lb 5 oz (0.7 kg). Shipping 1 lb 15 oz (1 kg).

Dimensions: 8330A: 6-1/2" high, 5-1/8" wide, 11-1/2" deep. (165 x 130 x 285mm). 8334A: including stand, 6-1/4" high, 4-3/4" wide 5" long. (160 x 121 x 127 mm).

Accessories furnished: 7-1/2 foot (2.29 m) power cable. Adjustable base and support rod (pin mount) for detector.

Price: Model 8330A, \$650.00; Model 8334A, \$450.00.

CALCULATOR



CALCULATOR PERIPHERALS

Extended Memory; Buffer
Models 9101A, 9102A

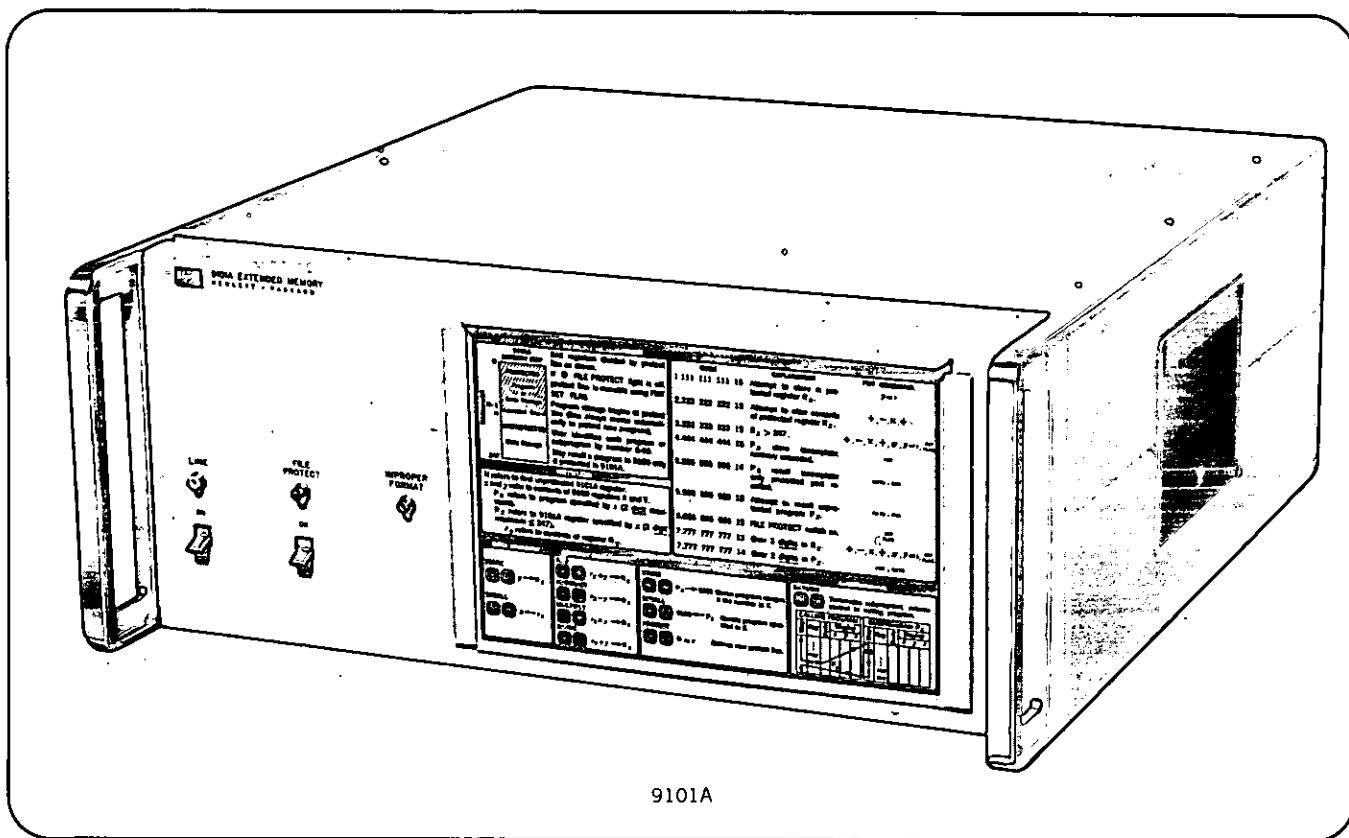

9101A

9101A Extended Memory

Description: The HP 9101A is an extended memory unit offering expanded storage capacity for the HP 9100 family of calculators. When attached to any 9100A/B output connector, the 9101A provides an additional 248 registers giving you greater programming and data handling flexibility. These registers are of the same configuration as the calculator registers and usable for storing data or instructions. The execution times for functions using the extended memory are comparable to the times to perform the same function using the calculator alone. A basic system configuration consisting of a 9100A/B calculator and a 9101A extended memory unit requires no interfacing unit. Additional peripherals such as the 9120A printer or 9125 plotter may be added to the basic system using a 9102A buffer unit.

Specifications

Command: The 9101A is addressed by the FORMAT (FMT) instruction from the calculator followed by a second instruction to define the desired operation (FMT) (). These commands provide for indirect addressing.

Memory Registers: There are 248 registers that may be used to store 248 constants or up to 100 programs (totaling 3,472 program steps), or a combination of constants and programs. Total of 20,832 bits of core memory.

Memory Protection: FMT SET FLAG protects the contents of consecutive registers specified by the user. Initial program protection is always automatic; the protected region expands to include a newly stored program.

Register contents remain intact when turning power on or off.

General

Temperature: Operating range, 0-45°C.

Weight: Net 30 lbs. (13,6 kg), Shipping 40.5 lbs. (18,4 kg).

Power: 115 or 230 V \pm 10% (slide switch), 50 to 60 Hz, 69 watts.

Dimensions: 7 $\frac{1}{2}$ " high by 16 $\frac{3}{4}$ " wide by 19 $\frac{1}{2}$ " deep. (184,9 mm. x 425,5 mm. x 490,5 mm.).

Purchase Plans

Purchase:	HP 9101A, \$3690
Rent:	\$195 per month
Lease:	\$84.90 per month
Service Contract available.	

9102A Buffer Box

Description: The HP 9102A buffer box is a necessary unit when you have a 9100 Calculator, 9101A Extended Memory and one or all of the peripherals. The buffer isolates the peripherals in a System and strengthens the output signals.

The buffer also allows for a longer cable to be attached to the 9101A. This optional 5' cable (Part Number 11162A-\$95) allows the 9101A to sit farther than the 18" standard cable.

Purchase Plans

Purchase:	HP 9102A, \$280
Rent:	\$15 per month
Lease:	\$6.45 per month
Service Contract available.	

CALCULATOR PLOTTER

Graphic Solutions — Series 9100 Calculators
Model 9125B



CALCULATORS

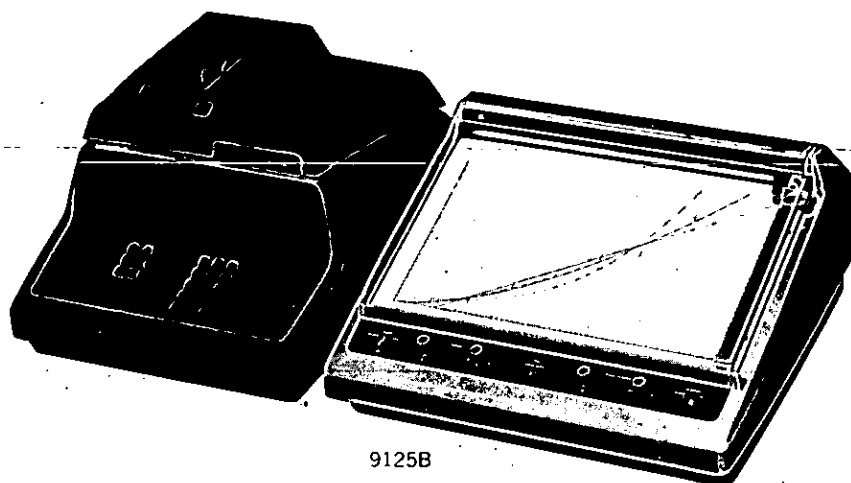

9125B

The 9125B Calculator Plotter is a higher speed successor to the 9125A. The 9125B presents graphic solutions to problems solved by the 9100 Series Calculators.

Automatic Plotting

The graphs plotted show the relationship between two or more variables. This relationship is ordinarily programmed in the Calculator which then automatically controls the Plotter. As the Calculator solves the problem, the Plotter graphs the results. The Calculator can also be used in the manual mode to transfer data coordinates to the Plotter directly.

High Speed Plotting

The 9125B adds high speed plotting to the 9100 calculator system. Graphs are plotted at approximately 2.5 points per second.

Excellent Reliability

Conductive film position—feedback elements are used in place of the conventional wirewound elements. The film feedback elements provide an order of magnitude increase in element life. The 9125B operates with either the 9100A or the 9100B Calculator.

Performance Specifications

Plotting area: 10 inches on the Y-axis by 15 inches on the X-axis. (25 cm by 38 cm on metric paper)

Origin: origin can be set anywhere on the plotting surface, allowing four-quadrant plotting.

Scale factor: 500 counts per inch (200 counts per cm) adjustable by at least ± 10 counts per inch (4 counts per cm) by front panel scale vernier control.

Plotting accuracy: ± 0.03 inches (0,08 cm).

Dynamic accuracy: deviation from straight line between two data points is less than ± 0.04 inches (1,0 mm) for data points up to 5 inches (12,5 cm) apart, at constant ambient temperature.

Resettability: ± 0.007 inches (0,18 mm).

Plotting time: minimum of 0.4 second from one plot point to the next. Total plotting time depends upon calculation time.

General Specifications

Temperature: operating range 5–55°C.

Weight: net 36 lbs (16,3 kg); shipping 48 lbs (21,8 kg).

Power: 115 or 230 V $\pm 10\%$ 48 to 66 Hz, 100 W.

Dimensions: 8½" high by 20" wide by 19¾" deep (213 mm x 500 mm x 484 mm).

Accessories furnished at no charge:

- 09125–90012 Operating Manual
- 09125–90014 Magnetic Card with Diagnostic Program
- 4040–0477 Dust Cover
- 09125–90011 Pull-out Instruction Card contained in the bottom of the 9125B
- 5080–3605 Slidewire cleaner
- 5080–3635 Slidewire lubricant
- 5080–7979 Package of 3 red pens
- 5080–7980 Package of 3 blue pens
- 9270–1004 Graph Paper (English), 20 sheets
- 9270–1024 Graph Paper (metric), 10 sheets

Purchase Plans

Purchase: HP 9125B \$2675.

Rent: \$200. per month.

Lease: \$69.50 per month.

Service Contracts available. Plotter Paper

To gain maximum benefit from the highly-accurate 9125B Calculator Plotter, we recommend precision-ruled plotting paper. Hewlett-Packard Company offers a wide variety of papers, available through all field offices. These are 11 in. x 16½ in. overall.

Price: \$4.90 per box (100 sheets).

Linear:

Part No.	Description
9270–1004	10 in. x 15 in. plot area
9270–1024	25 cm x 38 cm metric plot area

Semi-log:

9280–0159	10 in. x 2 cycle plot area
9280–0160	10 in. x 3 cycle plot area
9280–0169	2 cycle x 15 in. plot area
9280–0168	3 cycle x 15 in. plot area

Log-log

9280–0167	2 cycle x 3 cycle plot area
9280–0165	3 cycle x 2 cycle plot area
9280–0171	3 cycle x 4 cycle plot area



GRAPHIC PLOTTER

Graphics for IBM Communications Terminal
Model 7201A

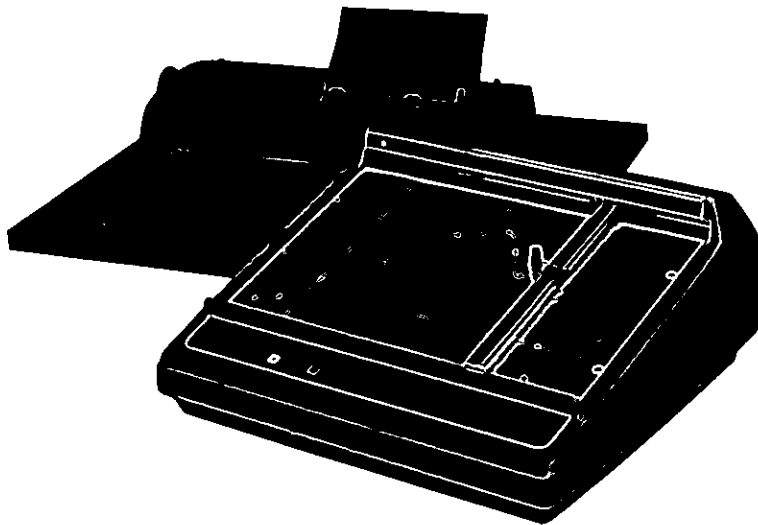

7201A

The 7201A Graphic Plotter is an absolute coordinate hybrid plotter that develops graphics by drawing vectors or plotting points. No backup software or previous programming knowledge is required for operation. The operator can input data or mathematical functions via source language programs on timeshare systems to produce charts or graphs.

The 7201A operates in conjunction with an IBM Communications Terminal. A plug-in interface cable completes the connection with the terminal. The plotter is controlled by mnemonic codes similar to those employed in timeshare systems. The plotter uses clean, easy-to-install disposable pens and electrostatic paper holddown. Easy maintenance is assured by modular construction using plug-in circuit boards.

Absolute coordinates

All points on the chart are defined by absolute coordinate pairs so that each plotted point is independent of the accuracy of preceding points. High-resolution position feedback is employed for maximum accuracy. Limit switches and improper data format detection are employed to minimize plotting of improperly formatted data.

Easy to use

The user can develop graphs directly without using backup software because the plotter accepts coding in a specified format. The format is easy to achieve in source languages such as BASIC, FORTRAN, or PL/I. Each coordinate pair is defined by a 4-digit X and 4-digit Y coordinate ranging in value from 0000 to 9999.

Simple commands

Mnemonic commands formed of standard characters are used to control the plotter. These commands place the plotter in either a point or line mode. Receipt of improperly formatted data causes the pen to lift, minimizing the probability of plotting erroneous data resulting from transmission errors. Plotting is automatically resumed at the next properly formatted point.

Specifications

Organization: The 7201A accepts digits which define the absolute address as a 4-digit X and 4-digit Y coordinate pair and plots points or vectors.

Graph limits: The X and Y graph limits are independently variable. The lower left corner can be placed anywhere in the lower left quarter of the plotting surface. The upper right corner can be adjusted so that the resulting graph will be anywhere from 5 x 7 in. to 10 x 15 in. (12,7 x 19,1 cm to 25,4 x 38,1 cm) in size.

Paper holddown: electrostatic.

Writing method: disposable ink pen (4 colors).

Input range: X and Y = 0000 for lower left, X and Y = 9999 for upper right.

Static plotting accuracy: ± 0.030 in. (0,076 cm).

Resolution: 0.005 in. (0,013 cm).

Resettability: 0.007 in. (0,018 cm).

Plotting speed: 0.8 s/point or vector.

Interface: IBM communications terminal compatible at 14.8 characters/s (EIA RS232).

Packaging: modular, major units packaged on plug-in assemblies.

Power requirements: 115/230 Vac, 50/60 Hz, 100 VA.

Weight: net, 40 lb (18,1 kg); shipping, 50 lb (22,7 kg).

Price: 7201A, \$ 3300.

Rental \$200./mo.*

Lease (min. 2 years) \$145./mo.

Options: (specify one)

001: Correspondence Code (Standard Selectric, Call/360; or APL) N/C.

002: BCD or EBCD Code (Standard or APL) N/C.

Accessories available

Plotter stand w/mounting plate (Model 17260A) \$75.

Mounting plate (Model 17261A) \$20.

*Plus service. Contact your local HP Sales Office.

COMPUTER SYSTEM

Disc Operating System

Big System Convenience, Small System Economy



COMPUTERS,
PERIPHERALS, DAS

System Description

By stressing modularity, Hewlett-Packard has produced a Disc Operating System (DOS) that can be custom configured for a variety of applications. DOS readily handles batch processing and other typically "large system" jobs; yet, it requires as little as 8192 words of core memory. The net result is a system that is very economical in view of the capabilities it provides.

DOS speeds and simplifies the creation, checkout and execution of programs. With this system a user can assemble or compile, load, and execute programs under control of the teleprinter keyboard or batch input device. Executive software automatically moves the assembler, compiler, loader, source programs, and intermediate versions of the program between bulk storage and core, as required, without the handling of paper tapes at each step.

For batch processing, DOS operates continuously to do a series of jobs, each of which can have independent programs and different I/O configurations. Source files can be edited, and a variety of files can be stored, dumped, and used as input to programs.

Hardware

The DOS is based on the field-proven HP 2116 or 2114 Computer. For operation as the central processor, the computer requires:

At least 8K of core memory.

Direct memory access for the high-speed transfer of information between bulk and core storage.

Memory parity check with interrupt.

Required peripherals include a disc memory for bulk storage and a teleprinter to perform system control, punching, and listing functions. For batch input the system uses a high-speed punched tape reader. Beyond these requirements, Hewlett-Packard can tailor the DOS for a given customer. The remaining I/O channels in the computer can service a combination of devices, including up to three additional discs, configured to meet the customer's particular needs. Extended capability devices are shown in the table below.

Extended Capability Devices

Function	Device	Advantage
Punch	Paper Tape Punch	120 char/sec output
List	Teleprinter	Low Cost
Input	Line Printer	356-1110 lines/min. speed
	Optical Mark Reader	Punched or pencil-marked card input at 200 cards/min.
System Input	High Speed Card Reader	Punched card input at 1000 card/min.
	Keyboard/Display	High-Speed visual display with edit capability
Computer	2116	Faster cycle time, core expansion to 32K, more I/O channels
Bulk Storage	Fixed-head Disc	160K words/sec input/output
	Miscellaneous Input/Output	Various
		Specialized I/O capabilities

Software

DOS comprises a series of relocatable binary software modules. Because each module is an independent, general purpose program, the configuration of DOS is quite flexible. A separate

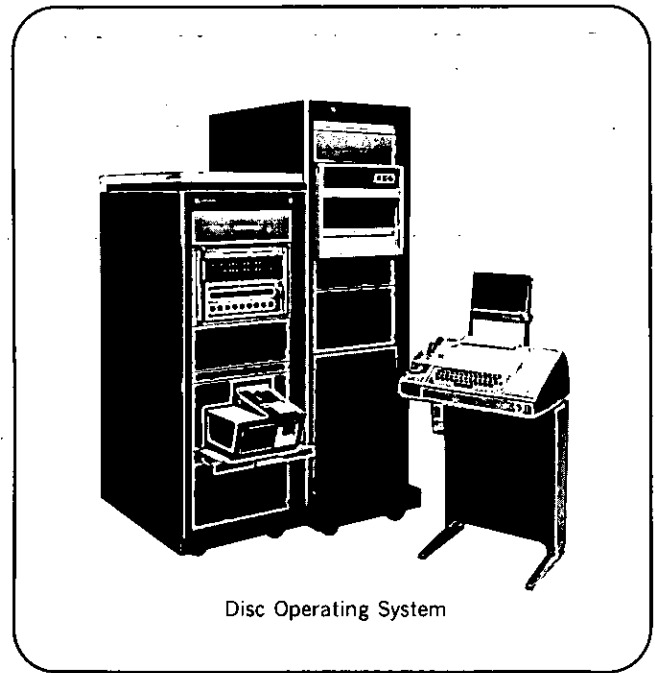

Disc Operating System

absolute program, DSGEN, accepts the software modules and generates a configured DOS, following dialogue-type instructions from the user. Certain DOS modules may be resident in either core or bulk storage. In a minimum 8K core system, all possible modules are resident in bulk storage; but a 16K or larger memory allows more modules to be core resident for faster processing. An absolute copy of the configured DOS is retained in bulk storage and is hardware protected against alteration.

Bulk Storage Layout

Bulk storage comprises three general areas: system, user, and work. In any configuration only the system area has a fixed size. DOS software modules reside in the protected system area. The user area holds files of user data and object program. The work area provides temporary storage for any program being executed and the object code that is generated by translators.

Core Layout

Core memory consists of a user program area and a system area. The system area holds those modules of the DOS Supervisor necessary to handle all requests, recall (if the module is not core resident) the required module from bulk storage, and transfer control to that module for processing. The user area provides space for execution of user programs; large DOS modules that reside in bulk storage are also executed in the user area of core.

DOS Prices

A minimum DOS hardware configuration starts as low as \$35,600; 115V, 60Hz operation or \$36,150; 230V, 50Hz operation. Provides minimum hardware consisting of an HP 2114 Computer (with 8K memory, direct memory access and memory parity check), a High-Speed Tape Reader, Cartridge Disc Memory (2.4 million bytes) and System Teleprinter (modified Teletype ASR-33). Contact your local HP computer specialist for further pricing information.



DATA COMMUNICATION INTERFACES

Models 12587A, 12622A, 12621A, 12618A, 12589A

Hewlett-Packard data communication interface cards permit the HP computer user to transmit data using a wide variety of privately-owned or common-carrier communication facilities. A full range of interface capabilities is available, permitting data transmission using either asynchronous or synchronous data modems. By including an automatic dialer interface, any data communications terminal in the system can be dialed under software control. Data may then be transmitted to or from the computer via the associated asynchronous or synchronous data modem and data communications interface card. Transmission modes include simplex, half-duplex, full-duplex (synchronous only) and echoplex. Conformance to EIA specification RS-232-B means your HP data communication system is completely compatible with equivalent data modems and automatic dialing equipment.

The data communication cards are easily programmed using HP Assembly Language subroutines. Character size and parity (odd, even or none) are software selectable. Asynchronous cards can be configured for number of stop bits (1 or 2) and clock frequency. Secondary channel control for "stop and retransmit," error correction subroutines, or for low-speed reverse data transmission is a standard feature. Built-in hardware capabilities reduce software engineering to a minimum. And the highly-efficient HP multi-level priority interrupt system keeps communication lines operating at maximum rates. All kits require one computer I/O slot except the 12618A Synchronous Transmit/Receive Interface Kit which requires two slots.

Specifications

12587A Asynchronous Data Set Interface Kit

Function: Asynchronous interface for HP 2100 Series Computers. Operates in the simplex, half-duplex or echoplex, transmit or receive mode.

Compatibility: Western Electric Type 103 or 202 Data Sets or equivalent.

Data Transfer: 100-150 or 800-1200 bits per second; character size*, 1-8 bits plus parity* (odd, even or none), stop bits (1 or 2) determined by strapping.

12622A (Transmit)/12621A(Receive) 12618A(Transmit/Receive) Synchronous Data Set Interface Kits

Function: Synchronous interfaces for HP 2100 Series Computers. Modes consist of simplex transmit (12622A), simplex receive (12621A), half or full-duplex.

Compatibility: Western Electric Model 201 or 203 Data Sets or equivalent.

Data Transfer: 0-9600 bits per second, 1-7 bits* plus parity* (odd, even or none) or 8 bits without parity.

12589A Automatic Dialer Interface Kit

Function: Allows an HP 2100 Series Computer to output data and control signals for operation of automatic dialing equipment.

Compatibility: Western Electric Model 801A or 801C Data Set.

Prices: 12587A, \$2,000; 12622A, \$2,000; 12621A, \$2,000; 12618A, \$3,000; 12589A, \$1,500.

*determined by control word

Punched Tape Readers

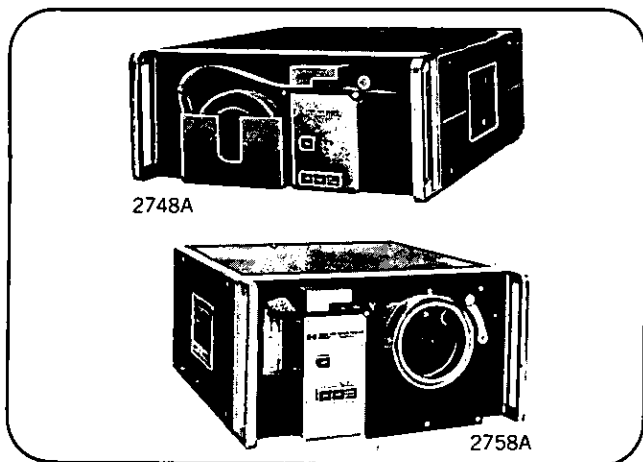

2748A

2758A

Description

The 2748A and 2758A Punched Tape Readers can rapidly and conveniently read-in data to your computers or other digital systems. Offering reading speeds to 500 characters per second, these readers permit greatly reduced read-in times while offering the economy and versatility of punched tape input. Significant advantages in reading accuracy are also provided. A new compensating, sensing technique ensures a maximum of reading accuracy using a wide range of materials. Opaque and oily tapes can be intermixed without the need for adjustment.

And for a maximum of operator convenience, the 2758A Tape Reader Reroller automatically rerolls the tape into the storage canister as it is read, eliminating the need for rewind-

ing. No special threading is required to use the reroller. Just insert the tape, snap in the clear plastic canister and the 2758A is ready to read and reroll.

Both the 2748A and 2758A are offered as a standard peripheral for all HP computers. All interface and software requirements for reader use with HP computers are readily available.

Specifications

Reading Speed: To 500 characters per second (415 characters per second when operated from 50 Hz power).

Reading Technique: Photoelectric, character by character

Tape: Code, 8 levels; Width, 1-inch; material, any material with less than 60% transmissivity.

Reroller Capacity (2758A only): 250 ft. maximum; minimum leader 3 ft. Self threading into canister. Rolls paper outside in. Metal mylar tape cannot be used in canister.

Start/Stop Times: Start, less than 6 msec; stop, less than 500 μ sec.

Dimensions: 7-inches high (2748A), 8- $\frac{3}{4}$ inches high (2758A), 17-inches wide, 16-inches deep not including panel controls and connectors.

Weight: 2748A — net, 42 lb. (19, 1Kg); shipping, 52 lb. (23, 7Kg) 2758A — net, 53 lb. (24Kg); Shipping, 60 lb. (27,2Kg)

Environment: Operating Temperature, 0-55°C; relative humidity to 80% at 40°C (limitation imposed by paper tape)

Input Power Required: 115V \pm 10%, 60 Hz \pm 5% or 230V \pm 10%, 50 Hz \pm 5%, 250W (Specify input voltage when ordering)

Price: HP Model 2748A, \$1,500; HP Model 2758A, \$3,000; add \$100 for 230V, 50 Hz operation; HP Model 12597A-002 Interface Kit for reader use with an HP computer, \$600.

DIGITAL TAPE RECORDER

OEM, On-Line, and Off-Line Applications
Model 7970A



COMPUTER PERIPHERALS

The 7970 is a high-performance, low-cost, on-line-tested digital magnetic tape unit that provides superior operational and reliability margins for small computers and off-line applications. It is capable of writing and reading industry-compatible IBM 7- or 9-track, 1/2-inch computer formatted tapes. (See also models 2020 and 3030.)

Modular construction is used throughout the 7970. In the basic transport, this includes the power supplies, motion control electronics, and control pushbuttons. Direct drive motors eliminate belts, pulleys, or gear trains. This results in an uncomplicated electromechanical assembly that is highly reliable and easy to maintain and service.

For the data electronics, each subassembly is physically and functionally separate on its own circuit board. Write and Read data electronics are divided into separate modules with two channels per board, plus a Write and a Read control board. This modular technique facilitates servicing, reduces spare parts, and precludes replacement of large and costly multifunction circuit board assemblies.

System Configurations

Modular construction also makes it possible to configure systems with varying requirements for OEM, Add-On, and End-User applications. The basic 7970A is a full 9-track tape unit for \$4700* that includes:

Write and Read Electronics (10-25 ips), 115/230 Vac, 48-400 Hz, Write and Read Head Assembly, Single Density (800 bpi), and Local Control.

Options for the basic 7970A are:

- 001 No Data Electronics (9-track)
- 002 Write and Read Electronics (7-track)
- 003 No Data Electronics (7-track)
- 004 Read Only Electronics (9-track)
- 005 Read Only Electronics (7-track)
- 006 Triple Density Select (200, 556, 800 bpi)
- 007 Unit Select (multiple-unit operation)
- 008 Horizontal Mounting
- 010 10 to 37.5 ips Tape Speeds
- 011 7- and 9-Track Read Only Electronics
- 013 Read Parity (7- or 9-track)
- 014 Write Parity (9-track)
- 015 Write Parity (7-track)

Interface To Hp Computers

For Hewlett-Packard computer users, the 9-track tape unit, with a 9-track interface kit and a software kit, may be used as a peripheral to configure a magnetic tape operating system. Systems and accessories available are:

- 7970A-200** Read After Write Electronics (25 ips). Requires 13181A Opt 001 Interface Kit and appropriate 13200A Software Kit.
- 7970A-202** Read After Write Electronics (37.5 ips). Requires 13181A Interface Kit and appropriate 13200A Software Kit.
- 7970A-247** Read After Write Electronics (12.5 ips). Requires 13181A Opt 002 Interface Kit and appropriate 13200A Software Kit.
- 13181A** Interface Kit (9-Track, 37.5 ips).
 - 001 9-Track, 25 ips.
 - 002 9-Track, 12.5 ips.

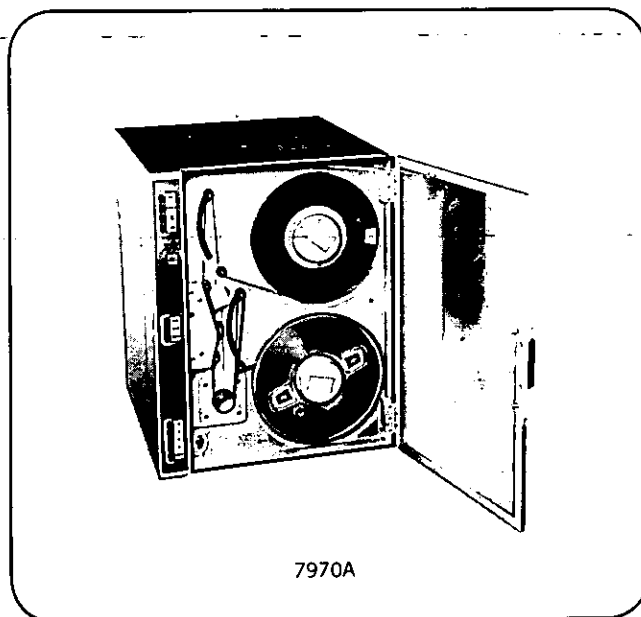

7970A

- 13200A** 8K Memory, Non-EAU** Software Kit.
 - 001 8K Memory, EAU Software Kit.
 - 002 16K Memory, Non-EAU Software Kit.
 - 003 16K Memory, EAU Software Kit.

Specifications***

Start/Stop Time Distance: IBM compatible, constant-velocity profile achieves $\pm 3\%$ of nominal speed within the start time. Long-term speed variations less than $\pm 1\%$.

Reel Time: approximately 3 minutes for 2400-foot reel.

Reel Diameter: up to 10 1/2 inches.

Tape Speed Range: 10 to 37.5 ips.

Interface Logic Levels: TTL compatible and Positive False.

General Specifications

Power Requirements: 115 or 230 ($\pm 10\%$) Vac, 48 to 400 Hz, single phase. 400 VA, maximum, (on high line).

Size: 19" wide, 24" high, 15 3/4" deep overall (12" from mounting surface) (483 x 610 x 400 mm).

Weight: 130 pounds, maximum (58.9 kg).

Environment: hardware temp range is 0° to +55°C, operating.

Accessories Furnished

One Instruction Manual, I/O Connectors, 1 Empty 10 1/2" Reel, 1 Extender Board, and 1 Power Cord.

Accessories Available

13191A Control and Status Test Board; 13192A Write Test Board; 13193A Read Test Board; 13190A Multi-Unit Cable; 9162-0027 Master Alignment Tape; 5952-5405 Model 7970A Interface Guide; 5080-4525 Transport Test Tape (7-Track); 5080-4526 Transport Test Tape (9-Track); 8500-0810 Head Cleaner; 9162-0025 Computer Grade (800 bpi) Magnetic Tape (2400 ft) on 10 1/2" Reel; and 9162-0026 Computer Grade (800 bpi) Magnetic Tape (1200 ft) on 8" Reel.

*OEM pricing also available.

**EAU: Extended Arithmetic Unit.

***Refer to Data Sheet for detailed specifications.

INTEGRATED CIRCUIT TEST EQUIPMENT



IC LOGIC PROBE AND CLIP

Test IC logic at a glance
Model 10525A Probe, 10528A Clip

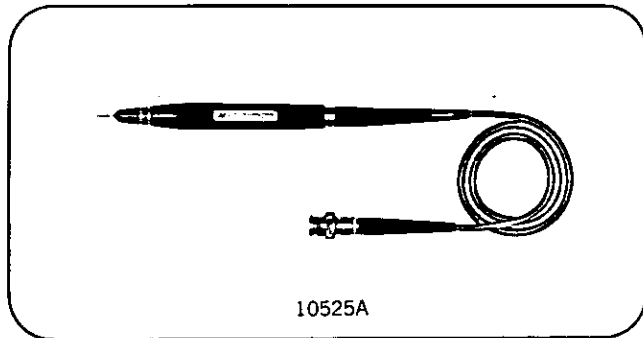

10525A

Model 10525A Logic Probe

Advantages:

Rapid Visual Pulse and Logic Level Indicator
Compatible with TTL, DTL and most other IC logic
Protected against Extreme Overload

Tracing logic levels and pulses through IC circuitry for logic design, maintenance checks, troubleshooting or training becomes easy with the Model 10525A Logic Probe. It has a preset threshold of 1.4 volts which is compatible with conventional TTL and DTL circuits. When touched to a high level or open-circuit, a band of light appears around the probe tip; when touched to a low level the light goes out. Single pulses of 25 ns or wider are stretched to give an indication time of 0.1 s. The light flashes on or blinks off depending on the pulse's polarity. Pulse trains up to 1 MHz produce partial brilliance; pulse trains from 1 MHz to 20 MHz produce either partial brilliance or momentary extinction, depending on duty cycle.

The circuit under test can first be run at normal speed while checking for the presence of such key signals as clock, reset, start, shift, and transfer pulses. Next, the circuit can be stepped, one pulse at a time while checking the truth tables of the logic packages for defects. A complete digital system can be checked by clocking it slowly through its internal states.

With no adjustments needed and with an indicator at the finger tips, the Model 10525A frees the user to concentrate on circuit analysis, rather than measurement technique.

Model 10525A functions equally well with logic schemes other than TTL or DTL, as long as the switching threshold is near 1.4 volts. It is not, however, compatible with ECL current mode logic. A variety of power connecting accessories makes connection to the required 5 volt power supply (eg., HP Model 6213A or 6214A) easy. The circuit under test can frequently provide the necessary drive.

Specifications

Input

Impedance: 10 k Ω .

Trigger threshold: +1.4 V, nominal.

Minimum pulse width: 25 ns.

Overload protection: -50 V to +200 V continuous, -200 V to +200 V transient, 120 V ac for 10 s.

Power: 5 V \pm 10% at 75 mA, BNC power connector. Internal overload protection to \pm 7 V supply.

Temperature: 0 to 55°C.

Accessories included: BNC to Alligator Clips, BNC to banana plug adapter, BNC bulkhead connector, ground cable assembly.

Price: Model 10525A, 1 to 4 units, \$95; 5 to 9, \$90; 10 to 20, \$85; for larger quantities, please consult Hewlett-Packard.

Model 10528A Logic Clip

Advantages:

Logic states at a glance
Self-powered, self-contained

This handy accessory clips onto TTL or DTL IC's and instantly displays the logic states of all 14 or 16 pins. Each of its 16 light-emitting diodes independently follows level changes at its associated input; a lighted diode corresponds to a high logic state. The behavior of gates, flip-flops, counters, and adders are visible at a glance. No power connections or adjustments need be made; the Logic Clip contains its own logic circuitry for locating the ground and +5 V pins. Buffered inputs ensure that the circuit under test will not be loaded down.

The Logic Clip and Logic Probe (described above) are designed to complement one another in both IC network development and troubleshooting. By presenting logic states and pulses simultaneously in an intuitive form—high states light indicators—they give the user a much broader view of circuit behavior, and circuit analysis becomes greatly simplified.

Specifications

Input threshold: 1.4 \pm .4 V; TTL or DTL compatible.

Input impedance: one TTL load (-1.6 mA typical per input).

Input protection: voltages <-1 or >7 must be current-limited to 10 mA.

Supply voltage: 5 V \pm 10% across any two or more inputs.

Maximum current consumption: 100 mA.

Price: Model 10528A, 1 to 4 units \$125; 5 to 9 units, \$120; 10 to 19 units, \$115; for larger quantities please consult Hewlett-Packard.

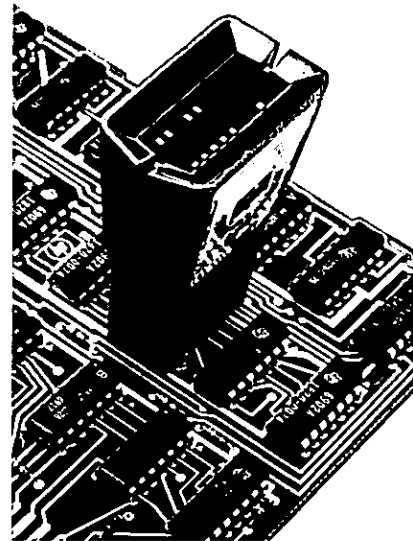

10528A

MULTIPROGRAMMER

Data Distribution system
Models 6936A, 6937A



COMPUTER PERIPHERALS

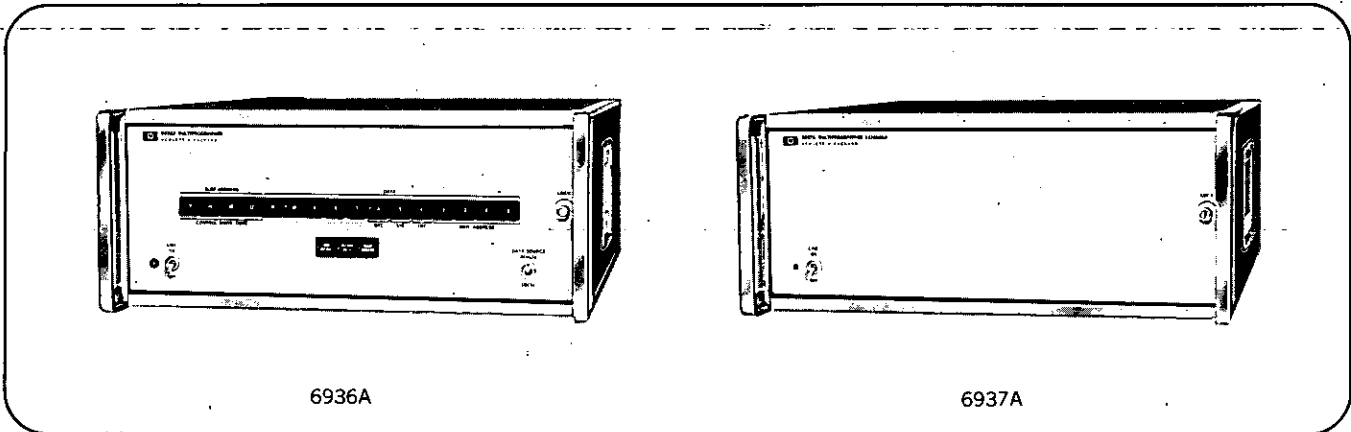

The Multiprogrammer is a computer-controlled digital data distribution system for programming many devices from a single computer or controller output channel. In its simplest configuration, one Multiprogrammer mainframe can control up to 15 devices; add-on capability enables a full system (containing 15 Extender mainframes) to program up to 240 devices.

Binary input to the Multiprogrammer is 16-bit parallel mode; randomly addressable outputs are available in several interchangeable forms:

- programmable resistance
- programmable analog voltage
- relay contact closures
- 12-bit binary logic levels

The output versatility of the Multiprogrammer suggests an almost unlimited number of programming applications, including:

Programming power supplies, variable loads, attenuators, filters, modulators, and function generators.

Driving CRT's, curve plotters, X-Y and strip chart recorders.

Switching solenoids, electrically operated valves, and alarm circuits.

Controlling servos and stepping motors, and testing memory systems.

For complete information on the Multiprogrammer System, Models 6936A and 6937A, contact your local HP Sales Office.

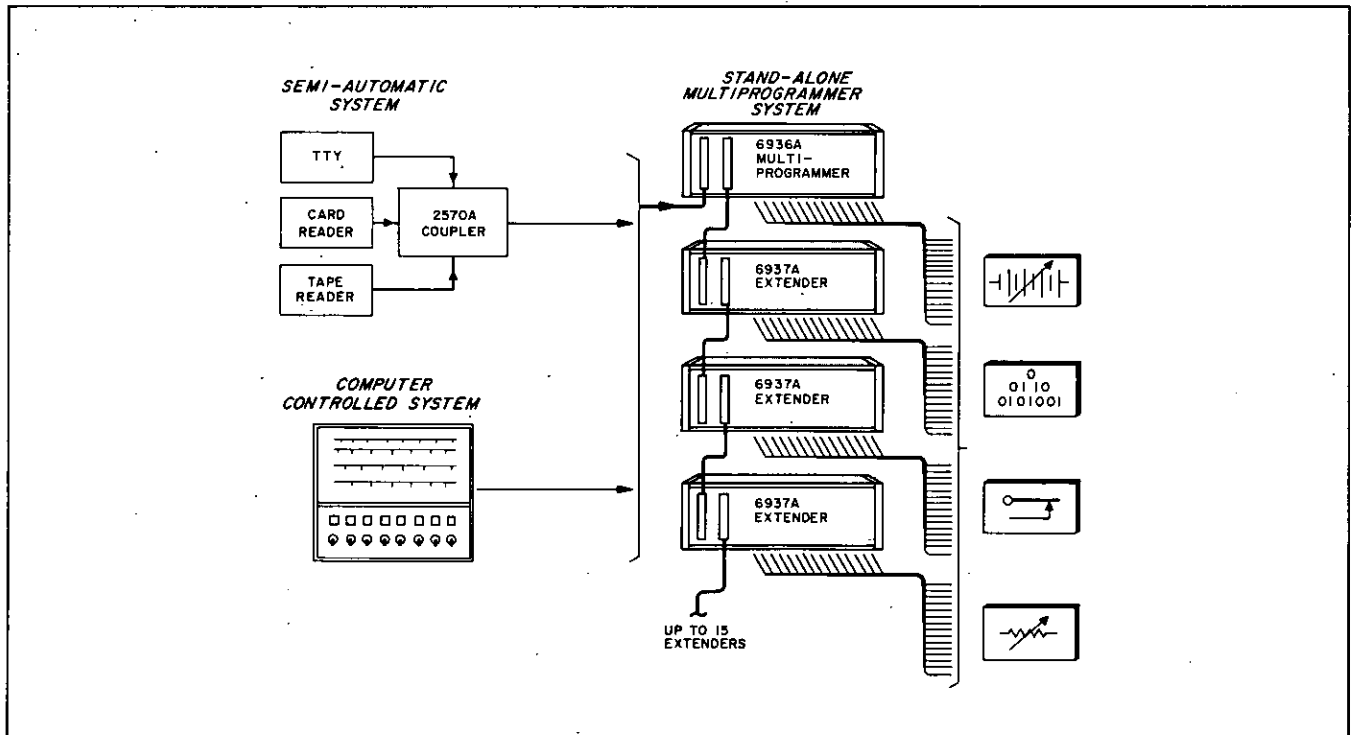

**COMPUTERS,
PERIPHERALS, DAS**



SPECTRUM STABILIZER; ADC SYSTEM
 Improve MCA Stability. Fast, accurate ADC
 Model 5586A Stabilizer; 5411A ADC

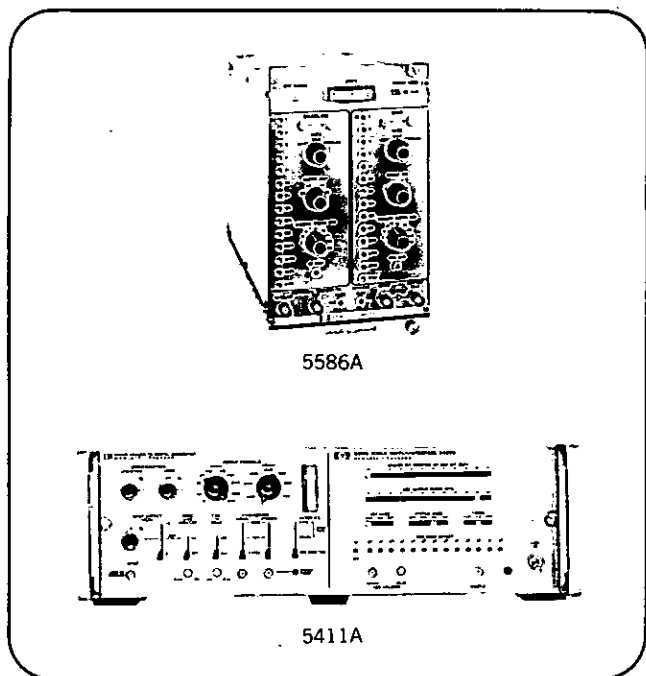

5586A

5411A

5586A Spectrum Stabilizer Stabilizes Gain and Baseline . . .
 DC coupled Built-in Correction Element . . . Drift Meter . . .
 Fine Gain and Baseline Setup Controls . . . Remote Control
 Capability . . . 4-width NIM

The Hewlett-Packard 5586A Nuclear Spectrum Stabilizer is designed to compensate for the analog drifts encountered in all nuclear detector/pulse height analyzer data systems. Each 5586A includes a Baseline (zero channel of a nuclear spectrum) and Gain Stabilizer. Using both assures the compensation of all drifts.

Drift compensation takes place in the correction element of the 5586A. This element is a dc coupled amplifier that has a nominal gain of X1 and controllable offset (baseline) and gain. Correcting for drifts in the stabilizer rather than the ADC minimizes the stabilizer interaction with the ADC and optimizes the spectral resolution of the pulse height analysis. Several features have been included in the 5586A that make it easy to set up and monitor. There is a meter that indicates how much compensation has been required to keep the spectrum from drifting; lights that indicate the direction of drift at any moment; and a light to indicate that the system drift has exceeded the compensation range selected on the stabilizer. It is possible to make small adjustments of gain and baseline during system set up using controls provided in the 5586A.

Either a feature of the nuclear spectrum or a pulser input to the system can be used as a reference for the 5586A; reference information can be accepted or rejected from the spectrum.

All the data from the ADC being stabilized by the 5586A is routed through the stabilizer and buffered on to the output data lines of the stabilizer. All the digital inputs and outputs are TTL level signals for maximum compatibility with a variety of ADC's, pulse height analyzers, and computers. The 5586A can be remotely controlled for use in computer systems. For full details request 5586A data sheet.

5411A ADC Subsystem

Features

5416B Analog-to-Digital Converter: 8192 Channel Resolution . . . DC coupled input . . . Integral Nonlinearity, <0.05% . . . Ultra Stable Conversion, <0.005% Drift/°C . . . 200 MHz Clock Rate

Optional Interfaces provide: Multiparameter Formatting . . . Multiplex scanning and coding . . . Live Timer . . . Complete Data Buffering . . . Interface to any general purpose computer with +TTL logic levels . . . Delayed Time Totalizing Control

Description

The Hewlett-Packard 5411A ADC Subsystem consists of the 5416B ADC and the 5410A Power Supply. These elements are part of the 5401B Multichannel Analyzer, the 5402A MCA System, the 5403A MCA/Calculator System and the 5406B Nuclear Analyzer System. Now the 5416B ADC can be added to any system that accepts +TTL logic levels.

For the improved resolution and efficiency of modern nuclear detector systems the 5416B ADC provides superior accuracy, stability, and analysis speed. When these features are combined with the flexibility and control of the optional interface packages, a powerful system element results.

Options to the 5411A provide Control, Live Timer operations, Data Formatting, and Data Buffering. These options are arranged to allow the choice of necessary functions yet allow for complete control and interface capability.

The 5411A is a self-contained unit; the ADC and Interface options plug into the 5410A Power Supply. For complete details please request 5411A data sheet.

Partial Specifications

OPTIONAL INTERFACE CAPABILITY

Inputs: 4 to 13-bit addresses from ADC, Ready for Data signal from Computer.

Outputs: 0 to 14-bit addresses from buffer storage to Computer, Data Ready signal to Computer, ADC Holdoff signal (500 ns to 3 μ s variable, 4.5 V pulse for slow coincidence gating of the ADC).

Controls

Timer: LIVE, CLOCK, or OFF; counts stored in channel zero of spectrum (10 counts per second).

ADC mode: Pulse Height Analysis, Sampled Voltage Analysis

System mode: Single Parameter (SGL), Multiparameter (MPR), Multiplex (MPX) Analysis, or Delayed Time Totalizing (DTT).

FUNCTIONS

Selects number of address bits output from buffer storage.

Selects digital offset to be applied to Interface output.

Provides digital formatting to allow one address to be formed from several ADC outputs in MPR operation.

Provides up to 4-bit code for each ADC in MPX operation.

5416B ANALOG-TO-DIGITAL CONVERTER: Same as 5416B Specifications 1970 Catalog, page 39.

5410A POWER SUPPLY: Provides all power requirements for 5416B ADC and Optional Interfaces. Provides crystal controlled clock for 5416B ADC and Live Timer operation.

GENERAL: 19" Rack mountable, 50-60 Hz, 115 V or 230 V operation. Temperature range: 0 to 55°C.

COUPLER/CONTROLLER

Programmable, Bidirectional Device Interface

Model 2570A



DATA ACQUISITION

The HP 2570A Coupler/Controller is an instrumentation coupler, an automated test system controller, a calculator or computer interface. Because it can perform many different functions, it can assume different identities.

The 2570A is a programmable, modular bi-directional link that interfaces as many as eight digital devices or peripherals to communicate with each other; thus it enables unattended data acquisition through its control of measuring instruments, stimuli, and logging devices. And because it can establish two-way communication, the 2570A can take full advantage of the computational and decision making capability of the HP 9100 calculator, any HP 2100 series computer, and most time-sharing systems.

Plug-in cards enable mating with measuring instruments — DVMs and counters . . . stimuli — voltage sources and frequency synthesizers . . . logging devices — teleprinters, high speed tape punches, and graphic plotters. As your system grows, various interfaces can be acquired.

The 2570A provides powerful capabilities that enable a wide range of activity, from programmed automatic control of small data acquisition systems to sophisticated control of instrumentation terminals and the processes they measure.

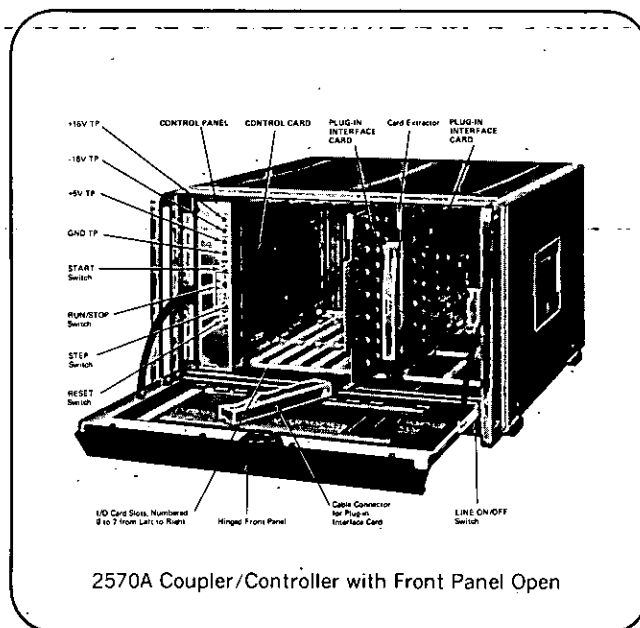

2570A Coupler/Controller with Front Panel Open

Operating Principles

Operation of the 2570A is based on the concept of providing a common communication code — ASCII (American Standard Code for Information Interchange). The main elements of the instrument consist of a control card with pinboard programmer for directing and programming system operation, a multi-line backplane for handling transfer of all input and output data and control signals, eight input/output slots for plug-in cards to interface I/O devices, and a self-contained power supply.

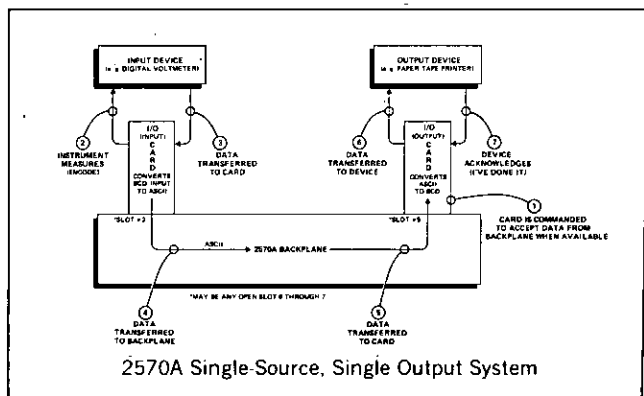

2570A Single-Source, Single Output System

The simple illustration shows how a device such as a DVM, inputs its data to the data coupler/controller which, in turn routes the data to an output device such as a paper tape printer. The sequence of operation is as shown: Note that the input data signal is converted from BCD to ASCII on the BCD input card; all data must be in ASCII when it reaches the 2570A backplane. Thus, a single 8-line ASCII bus on the backplane handles all data transfer between devices.

Assume now that the system is expanded to include two more DVMs plus a teleprinter. One at a time the DVMs input their data to the backplane where it is then transferred and output to either the paper tape printer or the teleprinter, or both. The input/output system is highly flexible, allowing any combination of input/output devices, i.e., any of the 8 posi-

tions can be used for input or output by merely plugging in the appropriate circuit board.

The highly diversified operating capabilities of the coupler/controller are all implemented under program control. All I/O operations can be programmed by either a self-contained pinboard programmer (up to 15 instructions) on the control card or by an external ASCII source, such as a teleprinter keyboard or tape reader.

The basic format for all instructions to the 2570A is in the form @ ac, where:

"@" informs the 2570A that this is an instruction. It alerts the 2570A to interpret the next two ASCII characters as address and command, respectively.

"a" is the numeric address of the card slot being commanded. It must be in the range of 0 through 7.

"c" is an alphabetic command to the card located in the specified card slot. This must be in the range of A through O.

To illustrate the relative ease of pinboard programming a complete measurement/recording cycle, consider again the single-source, single-output configuration shown in the illustration. Note that the DVM is interfaced through the BCD input card in slot 2, and the paper tape printer is interfaced through the BCD output card in slot 5. The complete program instruction for this specific example would be pinned into the programmer in the form:

```
@5I @2E @2O
(@ denotes that an address and command will follow)
```

Where:

@5I alerts the paper tape printer in channel 5 to print information

@2E encodes the DVM in channel 2 to take a reading

@2O instructs the DVM in channel 2 to output data when available

In addition to program instructions, the pinboard programming matrix can also accept standard ASCII words for the purpose of providing "header" information to any of the output devices.

The BCD input card also includes a data formatter allowing the operator to arrange the order in which the characters are recorded, insert special characters and source ID, indicate polarity, and reduce the length of the recorded word, if desired.

Applications

The 2570A is capable of serving in many different system applications, some of which are listed below.

1. Stand-alone system. The 2570A interfaces BCD instruments to an output recorder.

2. Calculator-based automatic test system. The HP 9100 Calculator adds decision making capability to a test system. The 2570A interfaces BCD measurement instruments, stimulus to the device under test, and the calculator.

3. Computer-based system. One or more coupler/controllers are used to extend and remote the computer I/O system, thus allowing multiple test stations to be under control of a single computer.

4. Time-sharing system. Single or multiple coupler/controllers interface test systems to time-sharing systems, thus enabling access to an on-line computer without investing in an in-house system.

An overall general description of the 2570A along with brief descriptions of compatible HP instruments is described in Application Note 130. Application Note 131 describes the 2570A in computer time-sharing systems, and Application Note 132 describes the 2570A in HP calculator systems. These application notes are available from Hewlett-Packard without charge.

Interface Cards

Interface cards for many applications are available as kits specifically for the 2570A. The interface cards generate the necessary interface control signals, provide storage if required, and provide the necessary control logic for I/O operations, e.g., proper timing conditions. The following is a brief description of interface cards available.

The **HP12797A BCD Input Card** equips the 2570A to receive the digital output from a variety of instruments, including digital voltmeters, counters and quartz thermometers. The card translates up to 10 characters of 8421 BCD information from a digital source into ASCII and makes it available in serial form on the 2570A ASCII bus. Patch panel programming on the card permits format control of the input/output slot, and insertion of certain special characters. The HP 12797A BCD Input card interfaces the following HP instruments to the 2570A: Counters: 5221A/B, 5245L/M, 5321A/B, 5323A, 5225A/B, 5326A/B, and 5330A/B; DVMs: 2401C, 2402A, 3450A, and 3480A/B; 2801A Quartz Thermometer; 4270A Capacitance Bridge.

The **HP 12798A BCD Output Card** provides a 10-digit parallel data output register as a means to interface the 2570A with parallel entry digital devices such as digital recorders or the frequency synthesizer programmer. In addition, the 12798A is suitable for providing general purpose 10-digit BCD output, such as needed for driving a variety of displays. The HP 12798A BCD Output card interfaces the following HP instruments to the 2570A: 2759B Frequency Synthesizer Programmer; Printer Paper Tape Recorders: 562AR, 5050A/B, and 5055A.

The **HP 12799A 16-Bit Relay Register** provides 16 programmable contact closures for control of external devices such as power supplies, solenoids, electrically activated control valves, or instruments requiring control voltage outside of the normal logic ranges. The contact closures may be subdivided in any combination for controlling one or several devices. The voltages switched through the relay contacts can differ from each other and from the 2570A ground by as much as 100 volts peak. Contacts can be connected in series, parallel, or series-parallel, with or without diode isolation. Floating contact

closure permits switching of diverse voltages and avoids ground loops.

The **HP 12800A 8-Bit Duplex Register** provides the 2570A with the capability to "talk" directly with 2100 series computers, the 2753A High Speed Tape Punch, and the 2748A/58A High Speed Punched Tape Reader. Through this interface, the computer can provide on-line computational power and can act as a system controller. Interconnect cables are available to allow the punch and reader to be operated independently or simultaneously (see 12800A specifications).

The **HP 12801A Teleprinter Interface** allows any HP teleprinter to interface with the HP 2570A. Compatible HP teleprinters, used mainly with computers and data acquisition systems, are the 2752A (modified ASR-33) and the 2754B (modified ASR-35); the 2749A (modified ASR-33) is used in HP time-sharing systems. A system incorporating a 2570A can be manually controlled by entering instructions from the teleprinter keyboard. Alternatively, the system may be controlled by paper tape programs read from the teleprinter tape reader.

The **HP 12802A Calculator Interface** enables the 2570A and the HP 9100 Calculators to communicate directly with each other. Data can be input through the 2570A to the calculator x-register and conversely, processed data can be output from the x-register through the 2570A, to such devices as a teleprinter or tape punch. Additionally, the program storage capability of the 9100 can be used to exercise system control. Through the use of a two-key sequence of "FMT" and a number or letter, the calculator can take readings from DVMs, counters, etc., control scanners, program power supplies, and in essence, do any of the things that can be done through the normal pinboard program. Furthermore, the 9100 brings computational power and decision making capability to the system for minimal cost.

The **HP 12803A Ten-Channel Reed Relay Scanner** switches multiple analog input signals, in either numerical or random sequence, to a single measuring device such as a DVM or frequency counter. Reed relays switch up to 10 channels per plug-in card. Up to six cards (60 inputs) can be used at one time in the 2570A. A two-digit channel identification is available for recording along with the data, or it may be suppressed, if desired.

The **HP 12807A Pinboard Program Card** provides 45 additional program steps for the 2570A. The steps are divided into five separate nine-step program segments, each of which can be treated as a separate subprogram that can be addressed directly and executed. A null step (no diodes inserted) determines the end of that subprogram. Program chaining is possible for programs longer than nine steps. More than one program card can be used at a time, greatly expanding programming capability.

The **HP 12809A Time-Sharing Interface** enables the 2570A to establish two-way communication with a time-shared computer. Any device interfaced to the 2570A also becomes interfaced to the computer, thereby enabling instruments and peripheral devices to communicate with each other and the computer. Thus, a system incorporating stimulus devices enables the computer program to control the process being measured. The time-sharing interface (and an acoustical coupler, as described in the specifications) allows data to be transferred on-line to a time-shared computer for analysis without the need for manual data logging and the subsequent re-keying of information into a computer terminal. Logging is performed unattended and can be recorded, automatically. All the mass data storage and powerful processing power of the most sophisticated computers are readily available without the capital outlay for an in-house system. Other benefits include access to pre-written statistical routines, capability of accumulating large historical files, and storing sophisticated programs at a low cost; these files are available on instant recall, making it possible to get maximum usage from the computer.

Specifications



(Most interface cards are supplied with a 48-pin PC connector kit, less cable, to allow the user to make his own device interconnecting cable; the kit is not supplied if one of the optional cables is ordered. The 10-channel scanner card is supplied with a 24-pin connector.)

2570A MAINFRAME

Input/Output Code: ASCII (8-Bit Parallel)

Programming: 15 I/O instructions or ASCII characters may be programmed using diode pins.

Power Requirements: 115V ac (2.5A) or 230V ac (1.25A), $\pm 10\%$, 48 to 440Hz, 275W

Character Transfer Rate: 200 kHz

Operating Ambient: 0° to 50°C (32° to 122°F)

Relative Humidity: to 95% at 40°C (104°F)

Dimensions: 10-1/2 inches (267mm) in 19-inch rack, 22 inch (559mm) depth behind panel, including clearance for heat sink and cables.

Weight: Net: 42 lb. (19kg), shipping: 60 lb. (27kg).

Accessories Available:

Program-Board Diode Pins: HP Part No. 5080-1620.

Price: \$2 each.

I/O Card Extender: HP 12805A. Service aid for I/O card.

Price: \$75.

Control Card Extender: HP 12806A. Service aid for control card.

Price: \$75.

Diagnostic Control Panel: HP 12804A. Programming and service aid. Makes all data, command and control lines available.

Price: \$400

Price: 2570A Mainframe including plug-in control card capable of 15 program instructions, 64 program-board diode pins, and power cable: \$1625.

12797A BCD Input Interface Card

Input Capacity: 10 digits (+ 8421 BCD)

Serial Data Output to 2570A Backplane Bus: Up to 13 ASCII characters, including special characters, that can be added to format the data for computer or calculator input.

Weight: Net: 3 lb. (1,4 kg); Shipping: 5 lb. (2,3 kg)

Price: 12797A BCD Input Interface Card plus 48-pin connector kit (kit not supplied if optional cables are ordered), \$600.

Option 001 Cable, 8 ft. long, terminated with Amphenol 57-30500 receptacle. HP Part No. 02547-6040.

Weight: Net: 1.25 lb. (0,6 kg), shipping: 1.75 lb. (0,8 kg).

Price: \$50.

Option 002 Cable, 8 ft. long. Interconnects HP IC counters with P.C. BCD output. HP Part No. 02547-6063.

Weight: Net: 1.25 lb. (0,6 kg), shipping: 1.75 lb. (0,8 kg).

Price: \$50.

12798A BCD Output Interface Card

Output Capacity: 10 digits

Weight: Net: 3 lb. (1,4 kg), shipping: 5 lb. (2,3 kg)

Price: 12798A BCD Output Interface Card plus 48-pin connector kit (kit not supplied if optional cable is ordered), \$500.

Option 001 Cable, 8 ft. long, interconnects BCD Output Card and HP 5050A/B or HP 562AR Digital Recorder.

HP Part No. 02547-6040. Weight: Net: 1.25 lb. (0,6 kg), shipping: 1.75 lb. (0,8 kg).

Price: \$50.

Option 002 Interface for HP 2759B Synthesizer Programmer.

Price: No charge.

12799A 16-Bit Relay Register Interface Card

Relay Contacts: All contacts are normally open when power is off; contacts close individually in response to '1' bit states.

Maximum Power: 10W peak or continuous, per contact.

Maximum Voltage: 100V peak or continuous across open contacts, between output connector pins, and with respect to controller ground on the register card.

Maximum Current: 500 mA per contact, peak or continuous.

Data Output: 16 floating relay contacts, with ratings as specified above. See "Relay Contacts".

Weight: Net: 3 lb. (1,4 kg) shipping: 5 lb. (2,3 kg)

Price: 12799A 16-Bit Relay Register Interface Card Plus 48-pin connector kit, \$500.

12800A 8-Bit Duplex Register Interface Card

Data:

Output High: 12V $\pm 10\%$, 10K source (jumper selectable) or 5V $\pm 5\%$, 10K source.

Low: 0 to 0.5V; sink 15 mA to ground.

Input High: 3.0V to 50V

Low: 0 to 1V; sink 5 mA to ground

Flags

One incoming (device) line and one outgoing (control) line are provided for both inputting and outputting.

Voltage

Output.....Same as Data Output

Input.....Same as Data Input

Weight: Net: 3 lb. (1,4 kg), shipping: 5 lb. (2,3 kg)

Price: 12800A 8-Bit Duplex Register Interface Card plus 48-pin connector kit (kit not supplied if optional cables are ordered), \$500.

Option 001 Interconnects 8-Bit Duplex Register to HP 2748A (or 2758A) High Speed Punched Tape Reader (only).

Price: \$50.

Option 002 Interconnects 8-Bit Duplex Register to HP 2753A High Speed Tape Punch (only). HP Part No. 12597-6005.

Price: \$50.

Option 003 Interconnects 8-Bit Duplex Register to HP 2748A (or 2758A) and HP 2753A (Y-shaped cable). HP Part No. 12800-60002.

Price: \$75.

Option 004 Interconnects 8-Bit Duplex Register to HP 2100 Series Computer. HP Part No. 12800-60003.

Price: \$50.

12801A Teleprinter Interface Kit

Code: Eight level, 11 unit ASCII code; 10 characters/second.

Compatibility: Interfaces any of the following teleprinters with the 2570A: HP 2752A, HP 2754B, HP 2749A. **Weight:** Net: 3 lb. (1,4 kg), shipping: 5 lb. (2,3 kg).

Price: 12801A Teleprinter Interface Card, \$450.

12802A Calculator Interface

System Speed: Input: 20 readings/sec. Output: 20 readings/sec.

System Programming: In addition to the 15 program steps in the 2570A, the calculator interface includes 15 routines hardwired on the interface card, plus 4 user-programmable routines. **Compatibility:** Interfaces with HP 9100 Series Calculators. **Weight:** Net: 1 lb (0,454 kg), shipping: 2 lb. (0,908 kg).

Price: HP 12802A Calculator Interface Card plus interconnecting cable, \$1775.

12803A Ten-Channel Reed Relay Scanner

Configuration: 10 ea. reed relays, 2 pole, form A. Common output bus, 2 line.

Input Connector: 24-pins (2 wires per channel)

Absolute Maximum Ratings: Open Circuit Switch Voltage, absolute maximum (line to line or line to HP 2570A ground):

120V at 1W ($\pm 60V$ mixed polarity), 50V at 5W ($\pm 25V$ mixed polarity). Short Circuit Switch Current, absolute maximum: 150 mA at 5W.

Signal Path Specifications:

Differential Thermal Offset: $< 50\mu V$

Single-Line Thermal Offset: $< 100\mu V$

Scanning Speed (Maximum Permissible):

(After receipt of scan advance command, scanner interrupts 2570A program control for 2.7 ± 0.5 ms, including relay switching time): 300 channels/sec.

Weight: Net: 1 lb. (0,454 kg), shipping: 2 lb. (0,908 kg)

Price: 12803A Ten-Channel Reed Relay Scanner plug-in card plus 48-pin connector kit, \$600.

12807A Pinboard Program Card

System Programming: In addition to the 15 program steps in the 2570A, the pinboard program card includes 45 program steps (5 subprograms with 9 steps each)

Program Source: Subprograms may be called from any ASCII source or program card in 2570A

Weight: Net: 1 lb. (0,454 kg), shipping: 2 lb. (0,908 kg)

12809A Time-Sharing Interface

Code: Eight level, 11 unit ASCII code; 10 characters/second.

Compatibility: Interfaces to the HP 2749A Teleprinter or any EIA compatible teleprinter.

Recommended Acoustic Coupler: The Anderson-Jacobson ADC 262 Acoustic Coupler, or equivalent, is recommended (EIA port necessary).

Price: HP 12809A EIA Teleprinter/Acoustic Coupler Interface Card plus interconnecting cables, \$1500.

DIGITAL RECORDERS



DIGITAL RECORDER

10 lines/s with economy and quality
Model 5055A

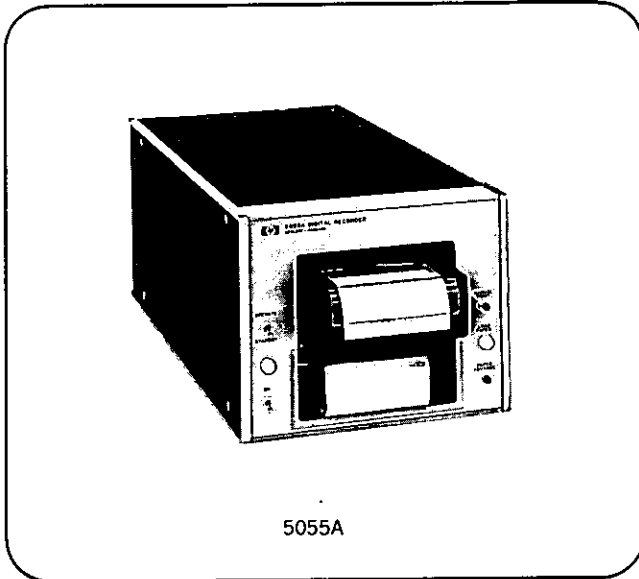

5055A

Hewlett-Packard Model 5055A Digital Recorder provides a high-performance economical method of making permanent records of digital data. The unit is supplied with complete electronics for 10 columns of input data and will print at rates up to 10 lines per second. It accepts TTL integrated circuit logic levels in either a +8421, or -8421 code, the code being switch selectable on the rear panel.

Quiet, reliable operation is inherent in the design, resulting from the use of very few moving parts. The printer mechanism, manufactured by Hewlett-Packard, is a modified version of a mechanism whose reliability and serviceability has been demonstrated in other HP recorders for years.

The 5055A prints in ink on regular paper or on pressure sensitive paper. For ink printing, the mechanism includes a continuously rotating ink roller - inherently a more reliable system than a start-stop ribbon mechanism. Paper loading is easy from the front, and when the paper supply runs out, an alarm lamp lights and recording stops automatically. An output signal is provided for inhibiting the data source.

Each column has an individual print wheel which can be changed independently if a different character set is desired in any column. Special wheels can be factory installed at nominal cost or may be field installed at a later date.

The recorder's cabinet is half-rack width and only six inches high. It can be used either on a bench or side by side with another instrument in a rack.

Specifications

Accuracy: Identical to input device used.

Print Cycle Time: 100 ms.

Printing Rate: 10 lines/sec maximum, asynchronous.

Print Wheels: 16 positions, numerals 0 through 9, +, -, V, A, Ω, *, special wheels available at minimal cost.

Column Capacity: Supplied complete for 10-column operation.

Electrical:

Data Input: Parallel entry, BCD ±8421 (selected by rear panel switch).

Blanking: HP counters with blanking will give insignificant zero suppression since blanked digit's output is (1111). May be defeated with rear panel switch.

Logic Levels: High state $\geq +2.4$ V, +5 V maximum (open input line results in high state); low state $\leq +0.4$ V (1.6 mA max., low), 0 V minimum.

Print Command: Line 1-low to high transition causes print (nominal 1 kΩ input impedance); Line 2-high to low transition causes print (nominal 400 Ω input impedance). Voltage levels are same as logic levels above, and a minimum pulse width of 0.5 μs is required.

Inhibit Voltage: (+) Inhibit = transition from $\geq 0, \leq 0.4$ V to ≥ 2.4 V, ≤ 5.0 V upon receipt of print command. Remains at high state until paper advance occurs, approximately 85 ms (< 5 mA in low state).

(-) Inhibit = inverse of (+) inhibit.

Line Spacing: Fixed, 4 to 5 lines per inch.

Inking: Ink roller or pressure sensitive paper. Pressure sensitive paper is recommended for operation under extreme temperatures.

Accessories Furnished: One pad regular paper, one pad pressure sensitive paper, one ink roller, one paper deflector, one power cable.

Operating Temperature: 0°C to +50°C with pressure sensitive paper, +10°C to +40°C with ink roller.

Input Connector: Amphenol 57-40500-375, HP Part No. 1251-0087, 50-pin female. Mating input cable connector: Amphenol type 57-30500-375, HP Part No. 1251-0086, 50-pin male.

Front Panel Controls: Power switch, power on indicator light, manual print pushbutton, manual paper advance pushbutton, out-of-paper light, standby/operate switch. (Paper loaded from front.)

Paper Requirement: HP folded tape. Approximately 15,000 lines per pad of regular paper, 18,000 lines per pad of pressure sensitive paper (pad fills 5055A twice and must be divided).

Power: 115 or 230 V $\pm 10\%$, 60 or 50 Hz (two-speed motor pulley incorporated), approximately 25 W idle, 55 W at 10 lines/sec.

Dimensions: Cabinet: 8" wide, 6 1/2" high, 16" deep (203 x 154 x 406 mm).

Weight: Net, 18.5 lb (10 kg) (approximately). Shipping, 22 lb (8.9 kg) (approximately).

Price: \$1,150.00

Accessories Available: Rack Adapter frame 5060-0797, \$25.00.

Option 001: Delivered set up for 50 Hz operation. No charge.

Option 002: Input cable, 562A-16C. For use with 3450A*, 3480A/B, 5326A/B, 5500A*, 8443A. \$50.00.

Option 003: Input cable, 10513A. For use with 5216A*, 5221B*, 5321B*, 5325A/B, 5330A/B, 5331A/B*, 5332A/B*. \$65.00.

Option 004: Input cable, 10524A. For use with 5323A. \$65.00.

*Slight modification may be necessary.

Description	Part Number
Ink Roller (Black)	9260-0071
Standard Paper (Single Pad*)	9281-0386***
Standard Paper (Carton of 15 Pads*)	05050-8002***
Pressure Sensitive Paper (Single Pad**)	9281-0387***
Pressure Sensitive Paper (Carton of 15 Pads**)	05050-8003***

*One pad of standard paper is 250 feet long.
**One pad of pressure sensitive paper is 305 feet long.
***Each pad fills 5055A twice and must be divided.

PLUG-IN MODULES

Expanded recording capability
Models 17505A & 17177A



RECORDERS

100 μ V Input Module - Model 17505A for 7100 Series Strip Chart Recorders

The 17505A High Sensitivity Input Module expands the sensitivity capability of the 7100 Series of strip chart recorders to 100 μ V full scale. Maximum sensitivity allows input signal variations smaller than 1 μ V to produce accurate measurable recordings.

Two scales of zero suppression, input filter, and zero check, are standard. Ten scales of calibrated zero suppression are available as an option. This suppression (Option 001) increases the resolution of the 17505A an order of magnitude. The selected suppression is unaffected by adjustment of the input vernier control.

For more information on the 7100 Series recorders and on companion input modules refer to pages 124 and 125 of the main catalog.

Specifications

Voltage spans: 0.1, 0.2, 0.5, 1, 2, 5, 10, 20, 50, 100, 200, 500 mV, 1, 2, 5, 10, 20, 50, 100 V full scale; Vernier provides continuous overlapping coverage.

Type of input: single ended, floating.

Input resistance: 1 M Ω .

Maximum allowable source resistance: 10 k Ω on six most sensitive ranges, no restriction on others.

Normal mode rejection: switchable, >60 dB or >100 dB at line frequency.

Common mode rejection: 120 dB at dc and 100 dB at line frequency on six most sensitive ranges.

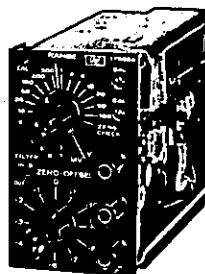

100 μ V to 100 V
17505A
(with Option 001)

Accuracy: $\pm 0.25\%$ at full scale.

Reference stability: $\pm 0.005\%/^{\circ}\text{C}$.

Zero set: zero may be set ± 2 full scale lengths from zero index. Zero check position on span selector.

Zero stability: $< \pm 1$ μ V after one hour at constant temperature between 10 $^{\circ}\text{C}$ and 40 $^{\circ}\text{C}$.

Weight: net, 2 lb (0.9 kg); shipping, 5 lb (2.2 kg).

Price: Model 17505A

\$400.

Options:

001 Calibrated offset: +1 to -10 scales of calibrated offset in one scale steps. Accuracy $\pm 0.25\%$ per step. \$100.

AC/DC Converter/DC Preamplifier-Model 17177A for 7004 Series and 7034A X-Y Recorders

The 17177A AC/DC Converter/DC Pre-Amplifier Plug-in enables you to make ac as well as dc recordings on your HP 7004B and HP 7034A X-Y Recorders. The 17177A offers a wide frequency range with high sensitivity. Its CMR allows accurate recordings in noisy environments. It is a double-width plug-in that can be used in either axis.

For additional information on the 7004B and 7034A X-Y Recorders and on companion plug-ins, refer to pages 117 thru 119 in the main catalog.

Specifications

Input ranges: 5 mV/in. to 20 V/in. (2.5 mV/cm to 10 V/cm) in 1, 2, 5 steps.

Minimum usable input (ac only): $\pm 0.2\%$ of full scale.

Maximum allowable input: 300 V peak.

Type of input: floating and guarded signal pair. Rear inputs not available.

Input impedance: 1 M Ω shunted by less than 40 pF.

Maximum allowable source resistance: 10 k Ω .

Common-mode rejection: 80 dB at dc and 50 Hz and above with 100 Ω between low side and guard connection point and at 5 mV/in. (2.5 mV/cm). On other ranges CMR decreases 20 dB per decade step in attenuation.

Rise/fall time (ac only, 10-90%):

Fast response (50 Hz to 100 kHz): 0.5 s maximum.

Slow response (5 Hz to 100 kHz): 2.5 s maximum.

Calibration (ac only): responds to average value of input waveform; calibrated in rms value of sine wave.

Accuracy: dc $\pm 0.5\%$ of full scale.

ac (expressed as percent of full scale).

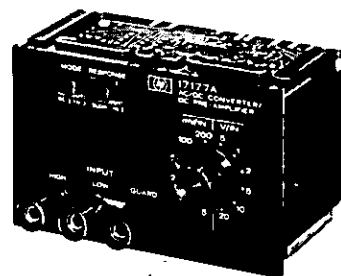

AC/DC Converter
DC Preamplifier
Model 17177A

Fast Response

50 Hz	150 Hz	50 kHz	100 kHz
$\pm 0.5\%$	$\pm 0.25\%$	$\pm 0.5\%$	

Slow Response

5 Hz	30 Hz	50 kHz	100 kHz
$\pm 0.5\%$	$\pm 0.25\%$	$\pm 0.5\%$	

Linearity: ac (expressed as percent of full scale, measured from 0.5% of full scale to full scale).

5 Hz	50 Hz	50 kHz	100 kHz
$\pm 0.35\%$	$\pm 0.25\%$	$\pm 0.35\%$	

Warm-up time: 3 minutes nominal.

Zero drift (referred to input): ± 30 μ V/ $^{\circ}\text{C}$.

Offset: up to one full scale of offset by use of recorder's zero.

Size: double width, occupies both plug-in spaces in axis.

Price: HP 17177A

\$500.

Options:

001 Metric scaled

N/C

RECORDER

10 in. AND 5 in. RECORDERS

Linear Motor Drive — Dedicated Applications
Models 7123A/B and 7143A/B

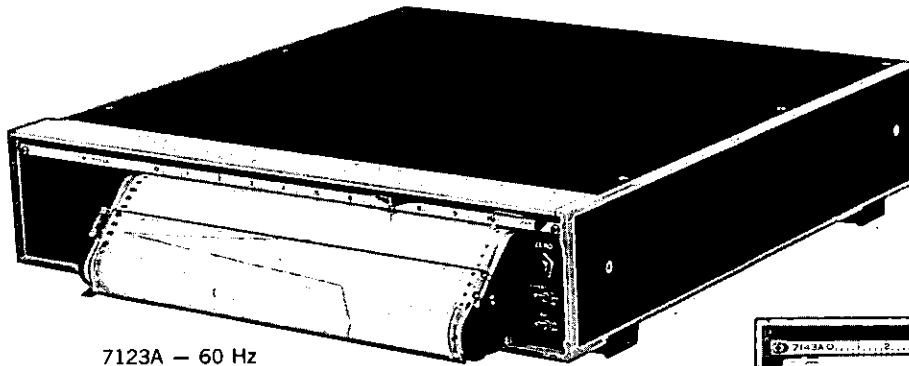

7123A — 60 Hz
7123B — 50 Hz

7143A — 60 Hz
7143B — 50 Hz

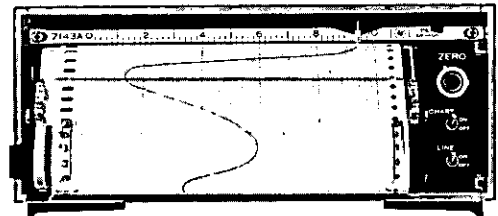

The 7123A/B and 7143A/B Strip Chart Recorders were developed specifically for dedicated recording applications. High reliability and exceptional performance plus a multitude of options allow custom tailoring to each application. These 3½ inch high recorders conserve rack space but still incorporate an effective chart drive and chart viewing system.

The 7123A/B uses chart paper with a 10 inch wide grid, the 7143A/B accommodates paper with a 5 inch grid. The suffix A denotes a recorder for use at 60 Hz line frequency; B denotes 50 Hz.

Reliability

Reliability is the keynote. Maximum reliability was achieved through the development of a unique linear servo motor. The motor enabled the design of a servo drive system with only one moving part — the motor slider/pen assembly. This single moving part replaces the many cables, pulleys, and gears found in a conventional servo system.

The entire radial field of the motor is produced by a permanent magnet, resulting in low power consumption and virtually no internal temperature rise. In addition, the motor can be driven continuously off scale with no audible noise and no possibility of damage to the recorder.

The traditional weak link of servo recorders has been eliminated. A conductive film potentiometer is used in place of the conventional wirewound slidewire. This conductive film potentiometer results in an order of magnitude increase in feedback element life.

Electric Writing

Electric writing (Option 036) is available to further enhance reliability and convenience. Using electrosensitive paper, the low voltage electric writing system provides a crisp, clear trace, eliminating the need for ink refilling and pen priming. The recorded trace is permanent, chemically stable, and insensitive to pressure and moisture. Totally unattended operation is achievable.

Precise Response

The linear motor also provides extremely quick response, producing full scale response in less than ¼ second (1/3 second for 7123A/B). In addition, non-mechanical tachometer feedback is incorporated. The tachometer and the high gain solid state servo amplifier allow the units to faithfully reproduce the input signal and respond to step inputs with less than 1% overshoot.

Versatile Chart Drive

A unique chart drive and viewing system is incorporated. The system allows the paper to be rolled up, or to be fed out and conveniently torn off for inspection or filing. The chart paper is driven at the bottom of the chart drive, insuring proper paper feed. In addition, a slanted viewing/writing area is incorporated to facilitate both viewing and note making. Chart paper may be manually advanced at any time without gear changing or performance interruption.

Minimum Panel Height

The unique linear motor and chart drive/viewing system combine to make a recorder that requires only 3½ inches of rack height. This low silhouette provides the user with additional rack space without sacrificing recorder capability.

Low Cost

The basic price is low. Additional savings are available when qualified for the OEM Purchase Agreement.

Flexibility With Options

With almost 50 options available, the 7123A/B and 7143A/B can be "designed" to fit your exact requirements. Most options are modular and options such as span and chart speed can be changed in the field if the need arises.

Performance Specifications

Input ranges: single span, 1 mV thru 100 V (specified by option).
Type of input: single ended, floating.
Input resistance: 1 M Ω constant on all spans.
Maximum allowable source resistance (R_s): 10 k Ω (unrestricted for spans below 1 V).
Normal mode rejection (at line frequency): > 40 dB.
Common mode rejection: 100 dB at dc and 80 dB at line frequency with 1k Ω between low and high side and common mode signal between low and ground.
Response time ($R_s \leq 10$ k Ω): 7143A/B: < 1/4 s (< 1/2 s for spans \leq below 1 V). 7123A/B: < 1/3 s (< 1/2 s for spans below 1 V).
Overshoot: < 1%.
Accuracy: $\pm 0.2\%$ full scale.
Zero drift: < $\pm 0.005\%/^{\circ}\text{C}$.
Linearity (terminal based): $\pm 0.1\%$ full scale.
Reference stability: $\pm 0.002\%/^{\circ}\text{C}$.
Chart speeds: speed determined by option choice.
Chart speed accuracy: synchronous with line frequency.
Zero set: left hand, adjustable ± 1 full scale (right hand optional).
Environmental (operating): 0 $^{\circ}\text{C}$ to 35 $^{\circ}\text{C}$, < 95% RH (25 $^{\circ}$ to 40 $^{\circ}\text{C}$).

General Specifications

Writing mechanism: servo actuated ink pen (electric writing optional).
Grid width: 7123A/B 10 in. or 25 cm. 7143A/B 5 in. or 12 cm.
Chart length: 100 ft or 30 meters (electric option 80 ft or 24 meters).
Pen lift: manual (electric optional).
Power: 7123A/7143A: 115/230V $\pm 10\%$, 60 Hz, 30 VA.
 7123B/7143B: 115/230V $\pm 10\%$, 50 Hz, 30 VA.
Dimensions: 7123A/B: 3 1/2" high, 17" wide, 19 1/4" deep (89 x 432 x 489 mm).
 7143A/B: 3 1/2" high, 8 1/2" wide, 19 1/4" deep (89 x 216 x 489 mm).
Weight: 7123A/B: net, 42 lb (19 kg); shipping, 51 lb (23 kg).
 7143A/B: net, 25 lb (11.3 kg); shipping, 33 lb (15 kg).
Price: 7123A/B: \$750.
 7143A/B: \$695.

Note: OEM discounts available.

Options for Special Requirements

Options:

Span (specify one, front scale determined by choice of English or metric chart speed).

Span	Option	Price	Span	Option	Price
1 mV (1.2)*	001	\$150.	1 V (1.2)*	N/C	008
5 mV (6)*	002	\$150.	5 V (6)*	N/C	009
10 mV (12)*	003	\$100.	10 V (12)*	N/C	010
50 mV (60)*	004	\$100.	50 V (60)*	N/C	011
100 mV (120)*	005	\$100.	100 V (120)*	N/C	012
500 mV (600)*	006	\$100.			

*Metric 7143A/B

Note: Additional spans are available on special order.

Speed	Option	Price	Speed	Option	Price
6 in./min	016	N/C	15 cm/min	022	N/C
4 in./min	017	N/C	10 cm/min	023	N/C
1 in./min	018	N/C	5 cm/min	024	N/C
1/2 in./min	019	N/C	3 cm/min	025	N/C
1/4 in./min	020	N/C	15 cm/hr	026	N/C
1 in./hr	021	N/C	3 cm/hr	027	N/C

Note: Additional speeds are available on special order.

Chart Speed Control

Description	Option	Price
60:1 speed reducer	028	\$20.
10:1 speed reducer	029	\$20.
4:1 speed reducer	030	\$20.

Remote speed change*	031	\$25.
Remote chart ON-OFF*	032	\$25.
Filter (adds 60 dB normal mode rejection)		
For spans 1 mV thru 5 mV,	007	\$45.
For spans 10 mV thru 100V,	013	\$30.
Electric Writing	036**	\$35.
Remote Pen Lift*	033**	\$20.
Event Marker (RH)*		
Ink	034**	\$40.
Electric	037**	\$35.
Right Hand Zero		
Hard (scale, 10 to 0)	014	N/C
Soft (scale, 10 to -0.5)	015	N/C
Retransmitting Pot		
4k Ω $\pm 3\%$ linearity (10 Vdc max)	039	\$50.
Limit Switch		
SPDT contacts (2A @ 30 Vdc resistive). Front panel adjustable.	040**	\$120.
Rack Slides (7123A/B only)	043	\$65.
Option Power Supply (required for options 031, 032, 033, 034, 036, 037, 040)	041	\$40.

*Actuated by contact closure to ground. Closed circuit current 1.5 mA (max), open circuit voltage +1.5 V (max).

**Requires Option Power Supply.

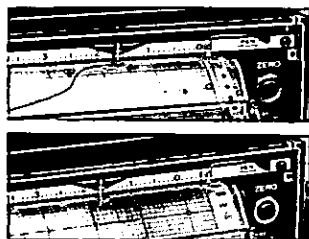

014 RH Hard Zero
015 RH Soft Zero

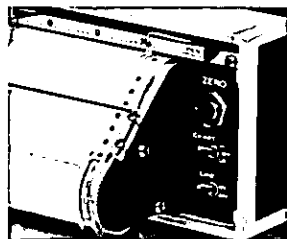

028, 029, 030
Speed Control

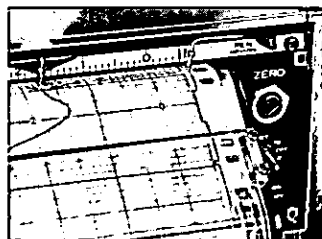

034 Ink
037 Electric

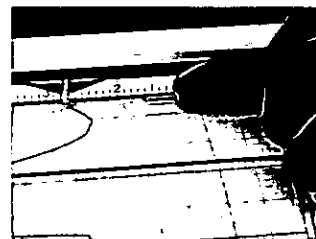

040 Limit Switch

ANALOG TAPE RECORDERS



INSTRUMENTATION RECORDERS

New Accessories and Options
3950 and 3960 Series

3950 Series - Option 011

Option 011 supersedes option 10. As before, it provides a 2.0 MHz bandwidth recording capability for the 3950 series tape recorders. However, option 011 now includes redesigned electronics and improved heads.

Option 011 alters only the frequency response and the output level specifications of the 3950 series tape recorders. For example, frequency response at 3¾ ips is 500 Hz to 62 kHz and at 120 ips, 500 Hz to 2.0 MHz. For option 011, output level is 0.5 Vrms into 75 ohms (adjustable). For complete specifications, request Option 011 Data Sheet.

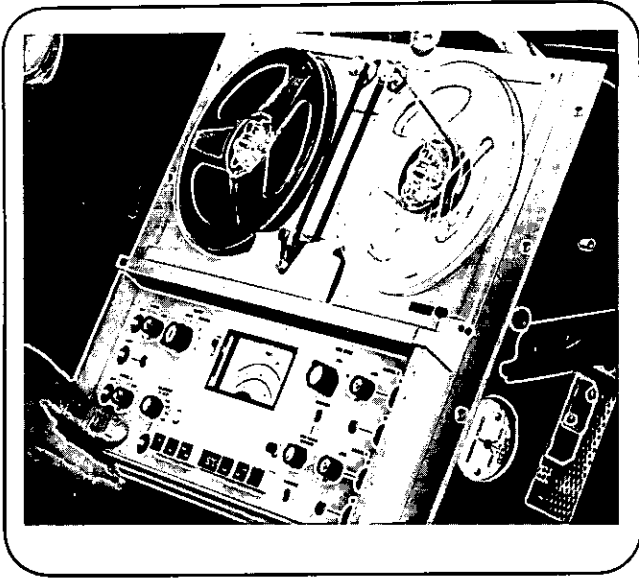

3960 Series Rack Slide Mounting Kit

For flush-mounting the 3960 portable tape recorder in cabinets and equipment racks. This accessory also allows the 3960 to be pulled away from an equipment rack and rotated 90° for easy access to all recorder adjustments. A protective housing, which replaces the portable case, may be removed while the recorder is still in the rack. With the housing removed, any of the printed-circuit boards can be removed and replaced.

Model 13068A (for standard 19" cabinets and racks)
\$165.00

Model 13068B (for HP 2940 cabinets) \$165.00

3960 Series DC-AC Inverter

The model 3960 portable recorder can be operated from a 12 or 28 Vdc power source using one of two accessory DC-AC inverters. Either inverter plugs directly into the 3960 and may be left inside when the recorder is operated from an ac power source. A power input cable is included with each inverter. Specifications are as follows:

13061A DC-AC Inverter: 12 Vdc to 1000 Hz, 115 Vac.
\$190.00

Input Voltage: 11 to 14 V, positive or negative ground.

Typical Current: At 12.5 V in Record mode: 7.0 amps. In

Stop mode (standby): 3.5 amps.

Weight: 1.4 lb (0.63 kg).

Size: Approximately 3¾" x 3¾" x 2¾".

13061B DC-AC Inverter: 28 Vdc to 1000 Hz, 115 Vac.
\$190.00

Input Voltage: 24 to 32 V, positive or negative ground.

Typical Current: At 28 V in Record mode: 2.8 amps. In

Stop mode (standby): 1.4 amps.

Weight and Size: Same as 13061A.

3960 Series Remote Control Option (050) \$380.00

This option allows electronic switching of all operating modes except tape speed and power on-off. Control lines select Forward Play, Reverse Play, Fast Forward, Fast Reverse, Record, and Stop modes with a momentary-contact closure. Status lines indicate the appropriate recorder mode. In a 3960 with the remote control option, the usual function switch assembly and the associated delay circuit assembly are replaced with momentary-contact switch-indicator assemblies, a logic printed-circuit board, and a relay printed-circuit board. Remote control is accomplished by an additional connector and harness connected in parallel with the switch-indicator assemblies. No external cabling or remote control box is provided.

The remote control option does *not* change any characteristic or specification of the recorder except that the "E-to-E" (electronics-to-electronics) mode is also activated during Reverse Record operation.

3960 Series Loop Adapter (13062A) \$370.00

The loop adapter for a 3960 portable Recorder is ideal where data analysis problems require *continual replay* of data into the analysis equipment or for any application that requires recording and continuously reproducing data without the necessity of stopping and rewinding tape.

The loop adapter can be installed in a few minutes on any model of the 3960 series recorder. Only three screws are used to mount the bin assembly over the right (take-up) reel hub and onto the deck casting. The supply hub, the take-up hub, and the bin cover snap onto the standard reel detents. A tape loop of from 5 to 30 feet can be loaded rapidly and easily.

Performance is essentially the same as for reel-to-reel operation except that only Forward Play can be selected. If any reverse mode is selected, the tape transport will shut off.

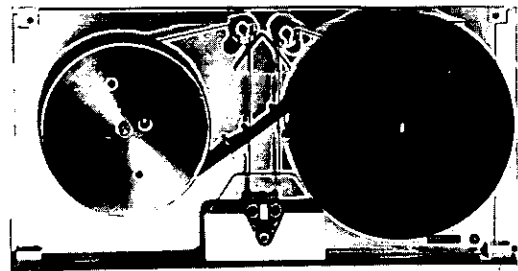

Tape Loop Adapter

Increased counter resolution at low frequency;
119.9 dB attenuation in 0.1 dB steps
Models 4022A; 4436A/4437A



FREQUENCY MULTIPLIERS ATTENUATORS

4022A Frequency Multiplier

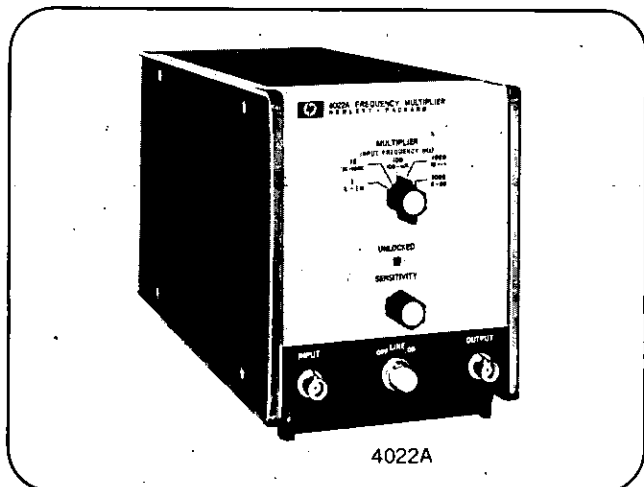

The Model 4022A Frequency Multiplier uses phase-lock techniques to improve the accuracy of low frequency measurements when used with conventional frequency counters, without resorting to a period measurement. The 4022A accepts the low frequency input signal and multiplies it by 10, 100 or 1000.

Tentative Specification, 4022A

Multiplier VS. Frequency range*

- X1 (no multiplier): 5 Hz to 1 MHz.
- X10: 1 kHz to 100 kHz.
- X100: 100 Hz to 10 kHz.
- X1000 (high range): 10 Hz to 1 kHz.
- X1000 (low range): 5 Hz to 50 Hz.

Signal input

- Sine wave sensitivity: 100 mV rms.
- Pulse sensitivity (internal control adjusts for positive or negative pulses): 500 mV peak down to 5% duty factor.
- Impedance: 1 M Ω shunted by 50 pF.
- Overload at maximum sensitivity: <2 V rms for rated input impedance.
- Damage level: 150 V rms over sensitivity range. 250 V rms at minimum sensitivity.

Output

- Output voltage: >1 V peak into 50 Ω , positive pulse with approximately 0.25- μ s pulse width.
- Output frequency: 5 Hz to 1 MHz.

Accuracy**

- X1, X10 ranges: 0 count \pm counter accuracy.
- X100 range: \pm 1 count \pm counter accuracy.
- X1000 range: <500 Hz \pm 1 count \pm counter accuracy.
- 500 Hz to 1 kHz: \pm 2 counts \pm counter accuracy.

Phase lock time constants, typical

Frequency rate of change vs. phase lock maintainability

- 1 decade per 2 s, >100 Hz.
- 1 decade per 3 s, 10 Hz to 100 Hz.
- 1 decade per 8 s, 5 Hz to 50 Hz.

Lock time after decade step frequency change

- 1 s, >100 Hz; 1.5 s, 10 Hz to 100 Hz;
- 3 s, 5 Hz to 50 Hz.

Operating temperature: 0°C to 50°C.

Power: 115 or 230 V \pm 10%, 48-440 Hz, 10 W.

Dimensions: 5-1/8" wide, 6-3/32" high, 11" deep (130 x 155 x 279 mm)

Weight: Net, 6.5 lb (2.9 kg). Shipping, 8.5 lb (3.8 kg)

Price: Model 4022A \$760.

*Overranging 10% beyond specified limits.

**At 1 s time base.

4436A/4437A Attenuators

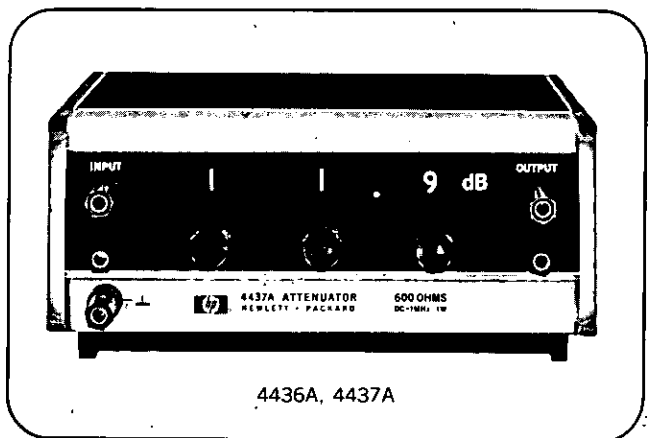

4436A, 4437A

Description

The HP Model 4436A/4437A Attenuators provide accurate steps of attenuation with 0.1 dB resolution for power-level measurements, communication system tests, and gain or loss measurements on filters and amplifiers, and similar equipment. Input/output impedance of the 4436A is 600 ohms balanced and the 4437A is 600 ohms unbalanced. The units are compact, light weight and rugged.

Tentative Specifications, 4436A

- Maximum attenuation: 119.9 dB
- Attenuation increments: 0.1 dB
- Input/Output impedance: 600 Ω , balanced
- Frequency range: DC to 1.5 MHz (0 to 110 dB) DC to 1 MHz (0 to 119.9 dB)
- Accuracy:

Attenuation	500 kHz	1 MHz
90 dB	\pm 0.2 dB	\pm 0.3 dB
110 dB	\pm 0.3 dB	\pm 0.5 dB
119.9 dB	\pm 0.5 dB	\pm 1.0 dB

Maximum input power: 1 Watt (24.5 V max.)

DC Isolation: signal ground may be \pm 300 V dc from external chassis.

Dimensions: 7 $\frac{3}{4}$ " wide, 3" high, 6 $\frac{1}{2}$ " deep (198 x 77 x 167 mm).

Weight: 3.3 lbs. (1.5 kg)

Price: Model 4436A, \$300.

Tentative Specifications, 4437A

The Model 4437A is a 600 ohms unbalanced type, and its specifications are identical to the 4436A.

Price: Model 4437A, \$255.

AMPLIFIERS



WIDEBAND AMPLIFIERS

Low Noise, Flat Response

Models 8447A, 8447B, 8447C, 8447D, 8447E, 8447F

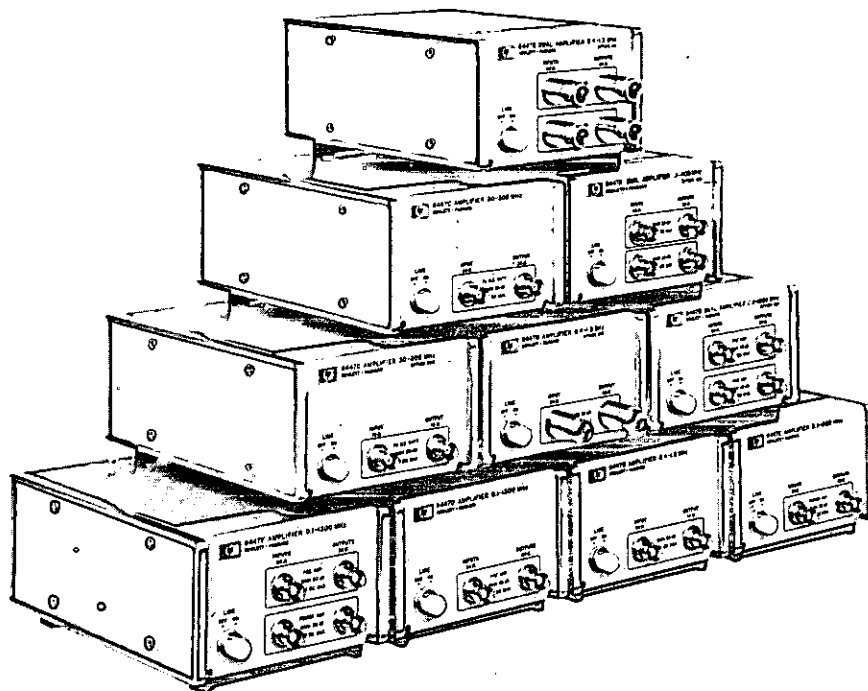

8447A, 8447B, 8447C, 8447D, 8447E, 8447F

Thin film hybrid integrated circuit amplifiers have been combined with fully regulated, solid state power supplies to form a series of general purpose amplifiers. The HP 8447 series of amplifiers embodies the inherently high reliability of integrated circuits and the convenience of a small, lightweight package.

High Performance: General purpose amplifiers have a variety of requirements imposed on them in day-to-day use, and each of these amplifiers has the performance necessary to qualify for a number of applications. The HP 8447 Amplifier series features low noise and wide bandwidth. Flat frequency response and low distortion assure accurate measurements with maximum utility. The hermetically sealed amplifier circuits insure long term stability and reliability.

Broad Frequency Coverage: The 8447 series offers an amplifier for nearly every application in the 100 kHz to 1.3 GHz frequency range. A wide range of options allows you to choose just the right amplifier for your application.

8447A 0.1 - 400 MHz Preamp: The 8447A offers an accurate 20 dB of low noise gain over the 0.1 - 400 MHz frequency range. With a noise figure of less than 5 dB and 0.5 dB flatness, the 8447A is an ideal amplifier for use with counters, spectrum analyzers, RF voltmeters, power meters, and other devices which often require improved sensitivity without degradation of amplitude accuracy. The 8447A is also available in a dual channel model for use with dual channel systems such as oscilloscopes and network analyzers. The two channels may be cascaded for 40 dB of low noise gain.

8447B 0.4 - 1.3 GHz Preamp: The 8447B, with a noise figure less than 5 dB to 1 GHz, acts as a partner to the 8447A for complete frequency coverage from 100 kHz to 1.3 GHz with low noise amplifiers. The 22 dB gain of the 8447B is especially useful for increasing the sensitivity of counters, spectrum analyzers, and EMI meters over the 0.4 - 1.3 GHz range where discrete component amplifiers are difficult to construct. Also available in a dual channel model, the 8447B may be used with such dual channel instruments as network analyzers for increased sensitivity.

8447C 30 - 300 MHz Amplifier: The 8447C operates over the complete VHF range, providing 30 dB of gain and 100 mW output power. The 8447C is an extremely useful general purpose amplifier for most any VHF application. Available in a 75Ω version as well as the standard 50Ω, it may be used to improve the sensitivity of VHF television and FM broadcast equipment. High output power (100 mW or more) allows use of the 8447C as a driver to increase signal generator output level for high level testing of RF circuitry.

8447D 100 kHz - 1.3 GHz Preamp: The extremely wide bandwidth of the 8447D makes it an ideal amplifier for general lab use. With 24 dB of gain and a low 8 dB noise figure, the 8447D adds the sensitivity needed for a variety of measurements. The wide bandwidth of the 8447D enables it to freely handle fast pulses with rise times greater than 0.5 nanoseconds with virtually no degradation, and it makes a fine preamplifier for wide bandwidth oscilloscopes. The 8447D is available in a

dual channel model also, and a wide range of dual channel instruments will benefit from the increased sensitivity.

8447E 100 kHz - 1.3 GHz Power Amp: Covering more than four decades in frequency, the 8447E offers 22 dB of low distortion gain and more than 20 mW output power for general use. The 8447E is ideally suited for such applications as increasing the maximum power available from a signal generator or sweeper. Here too, the wide bandwidth insures free passage of fast rise time pulses for maximum utility.

8447F 100 kHz - 1.3 GHz Preamp-Power Amp: The 8447F combines the preamplifier from the 8447D and the power amplifier from the 8447E in a single package. The input and output ports of both amplifiers are available on the front panel so that the two amplifiers may be used separately or cascaded for 46 dB of gain. The applications for this combination are practically unlimited. The 8447F fills most every amplifier need in the 100 kHz to 1.3 GHz range.

	8447A Preamp	8447B Preamp	8447C Power Amp	8447D Preamp	8447E Power Amp	8447F Preamp- Power Amp
Frequency Range	0.1 - 400 MHz	0.4 - 1.3 GHz	30 - 300 MHz	100 kHz - 1.3 GHz	100 kHz - 1.3 GHz	100 kHz - 1.3 GHz
Typical 3 dB Bandwidth	50 kHz - 700 MHz	0.35 - 1.35 GHz	10 - 350 MHz	50 kHz - 1.4 GHz	50 kHz - 1.4 GHz	50 kHz - 1.4 GHz
Gain (Midband)	20 dB \pm 0.5 dB at 10 MHz	>20 dB 22 dB Typical	30 dB \pm 1dB	24 dB \pm 1.5 dB	22 dB \pm 1.5 dB	↑ 8447D AND 8447E COMBINE IN A SINGLE PACKAGE ↓
Gain Flatness across full Frequency Range	\pm 0.5 dB	\pm 1 dB	\pm 1 dB	\pm 1.5 dB	\pm 1.5 dB	
Noise Figure	<5 dB	<5 dB 0.4 - 1.0 GHz <6 dB 1.0 - 1.3 GHz	<10 dB	<8 dB	<10.5 dB	
Output Power for 1 dB Gain Compression	>+7 dBm	>-3 dBm	>+19 dBm	>+7 dBm	>+14 dBm	
Harmonic Distortion	-35 dB for 0 dBm output	-30 dB for -15 dBm output	-35 dB for +10 dBm output	-40 dB for -5 dBm output	-30 dB for +14 dBm output	
Typical Output for <-60 dB Harmonic Distortion	-25 dBm	-45 dBm	-15 dBm	-25 dBm	-16 dBm	
VSWR	<1.7	2.0 Input 2.2 Output	<2.0	<2.0	<2.0	
Impedance	50 Ω	50 Ω	50 Ω Opt 002 75 Ω	50 Ω	50 Ω	
Reverse Isolation	>30 dB	>40 dB	>35 dB	>35 dB	>35 dB	
Maximum DC Voltage Input	\pm 10V	\pm 10V	\pm 10V	\pm 10V	\pm 10V	

Specifications

GENERAL

Power Requirements: 110 or 230 V ac \pm 10%, 48-400 Hz, 15 watts.

Dimensions: 8½ inches (216 mm) deep by 5¾ inches (130 mm) wide by 3¾ inches (85,8 mm) high.

Weight: Net, 3 pounds, 7 ounces (1,56 kg). Shipping, 5 pounds, 1 ounce (2,30 kg).

Prices:

Model 8447A	\$550
Model 8447B	\$600
Model 8447C	\$450
Model 8447D	\$700
Model 8447E	\$800
Model 8447F	\$1225

Options Available

	Option 001 Dual Channel BNC Connectors	Option 010 Type N Connectors	Option 011 Dual Channel Type N Connectors	Option 002 75 Ω Input and Output Impedance
8447A	Add \$400	-	-	-
8447B	Add \$450	Add \$50	Add \$500	-
8447C	-	-	-	Add \$10
8447D	Add \$500	Add \$50	Add \$600	-
8447E	-	Add \$50	-	-
8447F	-	Add \$100	-	-

METERS, VOM, P, Z, etc.



DIGITAL MULTIMETER

True RMS, DC & Ohms with readings up to 1000/s
Models 3480A/B, Plug-ins 3481A, -82A, -84A

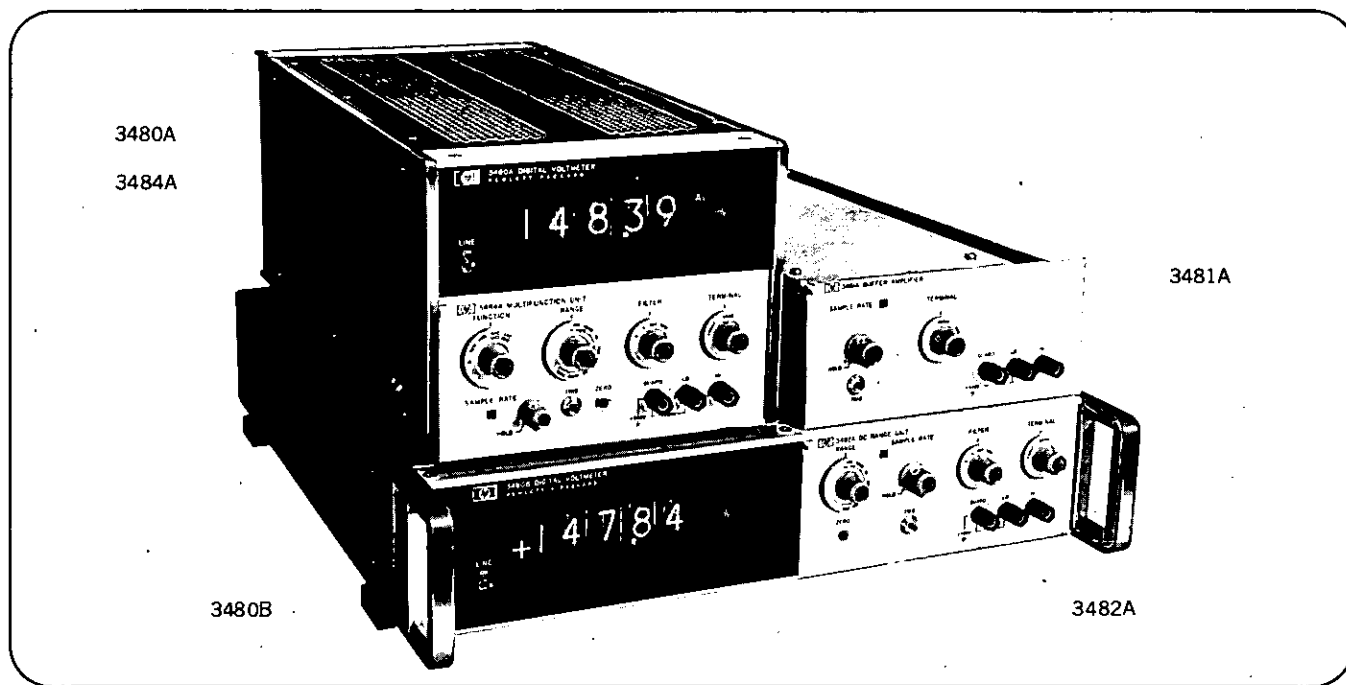

Description

The Model 3480A/B Digital Voltmeter is a multi-function DVM having a four full digit display with a fifth digit for 50% overrange capability.

The 3480A/B uses a successive approximation technique for A/D conversion. Because of its unique design in both the analog portion and in the method used for data transfer, up to 1000 readings/second are possible without performance degradation. This makes the 3480A/B ideal for computer controlled systems.

The 3480A/B is also ideal for bench applications. Its TRUE RMS ac converter enables accurate voltage measurements to be made on waveforms with frequency components from dc to 10 MHz. A three position filter provides selectable noise rejection when making dc voltage measurements. Measurement versatility may be expanded using other options and plug-ins.

The 3480A/B mainframe uses one of three plug-ins. The 3481A Buffer Amplifier provides a single dc voltage range; the 3482A DC Range Unit provides five dc voltage ranges and the 3484A Multi-function Unit, with all options, provides five dc voltage ranges, five TRUE RMS ac voltage ranges and six ohms ranges. When the input filter is switched out, 1000 readings/second are possible on all dc ranges and most ohms ranges. A front panel control allows readings to be taken from 1 to 25 per second.

The 3480A is a half-module bench type instrument while the 3480B is a full module rack version. All plug-ins fit either configuration.

AC Measurements

The 3484A, with the ac option, offers TRUE RMS voltage measurement in five ranges from 100 millivolt to 1000 volts full scale. TRUE RMS eliminates significant errors caused by small amounts of harmonic distortion present in most sinusoidal signals.

Non-sinusoidal signals may also be measured with a full scale crest factor up to 7:1. This converter may be dc coupled thus making it possible to measure a combined ac and dc signal. The ac frequency range is from 1 Hz to 10 MHz; this is outstanding for rms responding meters.

A dual-thermopile is used in the ac converter to achieve 30 times the sensitivity of a single thermocouple. This sensitivity permits accurate measurements on the 100 millivolt range.

DC Measurements

The 3482A or the 3484A has five dc voltage ranges from 100 millivolts to 1000 volts full scale - autoranging is standard. Input errors are virtually eliminated by the combination of an input resistance of $> 10^{10}$ ohms (three lower ranges) and a leakage current of < 10 pA. Normal-mode noise is reduced by a three position input filter. Common-mode noise is reduced by guarding.

Systems Options

These options combined with the millisecond sampling period, fast response time and rapid overload recovery, make the 3480A/B ideal for systems use. This variety of configurations allows the user to tailor his instrument to fit his specific needs.

Specifications

3480A/B With 3481A Buffer Amplifier DC Voltage

Range

Voltage range: ± 10.000 V. Overrange: 50%.

Performance

Accuracy: 90 days ($25^{\circ}\text{C} \pm 5^{\circ}\text{C}$, $< 95\%$ R.H.) $\pm(0.01\%$ of reading $+0.01\%$ of range).

Temperature coefficient: 0°C to 55°C : $\pm(0.001\%$ of reading $+0.0003\%$ of range) per $^{\circ}\text{C}$.

Measuring speed

Response time: 1 ms Reads within 1 count of final reading when triggered coincident with step input voltage.

Reading period: 950 μs .

Reading rate

Manual: reading may be manually initiated with front panel pushbutton.

Internal: 1 to 25 readings per s with front panel control.

External: 0 to 1000 readings per s with external trigger.

Note: Instrument meets dc voltage accuracy specification when rate of change of input voltage is less than 1 V/s during the reading period. If this rate of change is exceeded, voltage readings may not be within specification.

Input CharacteristicsInput resistance: $> 10^{10} \Omega$.**Shunt capacitance**High to Low, front terminals (filter out): $< 50 \text{ pF}$.High to Low, rear terminals (filter out): $< 80 \text{ pF}$.Guard to Low: $< 4000 \text{ pF}$.Guard to Chassis: $< 1200 \text{ pF}$.Common mode rejection: $> 80 \text{ dB}$, DC to 60 Hz (1 k Ω in either lead).Maximum input voltage: Guard to Chassis: $\pm 500 \text{ V peak}$; Guard to Low: $\pm 200 \text{ V peak}$; High to Low: $\pm 1200 \text{ V peak}$.**3480A/B With 3482A DC Range Unit****DC Voltage****Ranges**Full range display: $\pm 100.00 \text{ mV}$, $\pm 1000.0 \text{ mV}$, $\pm 10.000 \text{ V}$, $\pm 100.00 \text{ V}$, $\pm 1000.0 \text{ V}$.Overrange: 50% on all ranges. $\pm 1200 \text{ V}$ maximum input.

Range selection: manual, automatic or remote.

Automatic ranging: upranges at 140% of range; downranges at 10% of range.

PerformanceAccuracy: 90 days ($25^\circ\text{C} \pm 5^\circ\text{C}$, $< 95\% \text{ R.H.}$)100 mV range: $\pm(0.01\% \text{ of reading} + 0.02\% \text{ of range})$.All other ranges: $\pm(0.01\% \text{ of reading} + 0.01\% \text{ of range})$.**Temperature coefficient****100 mV range**Filter out: $\pm(0.001\% \text{ of reading} + 0.0005\% \text{ of range}) / ^\circ\text{C}$ Filter A or B: $\pm(0.001\% \text{ of reading} + 0.0015\% \text{ of range}) / ^\circ\text{C}$ All other ranges (with or without filtering): $\pm(0.001\% \text{ of reading} + 0.0005\% \text{ of range}) / ^\circ\text{C}$.**Measuring speed****Response time (without range change)**

Filter out: 1 ms. Reads to within 1 count of final reading when triggered coincident with step input voltage.

Filter A: 200 ms to within 1 count of final reading when triggered coincident with step input voltage.

Filter B: 1 s to within 1 count of final reading when triggered coincident with step input voltage.

Reading period: 950 μs .**Reading rate (without range change)**

Manual: reading may be manually initiated with front panel pushbutton.

Internal: 1 to 25 per s with front panel control.

External: 0 to 1000 per s with external trigger.

Input Characteristics**Input resistance**100 mV, 1000 mV, 10 V ranges: $> 10^{10} \Omega$.100 V, 1000 V ranges: 10 M $\Omega \pm 0.1\%$.**Shunt capacitance**High to Low, front terminals (filter out): $< 50 \text{ pF}$.High to Low, rear terminals (filter out): $< 80 \text{ pF}$.Guard to Low: $< 4000 \text{ pF}$.Guard to Chassis: $< 1200 \text{ pF}$.Effective common mode rejection (ECMR): ECMR is the ratio of the peak common-mode voltage to the resultant error in reading with 1 k Ω unbalance in either lead.DC: $> 80 \text{ dB}$

AC (50-60 Hz)

Filter out: $> 80 \text{ dB}$.Filter A: $> 110 \text{ dB}$.Filter B: $> 160 \text{ dB}$.

Normal mode rejection (NMR): NMR is the ratio of the peak normal mode signal to the resultant error in reading.

	50 Hz	60 Hz and above
Filter out	0 dB	0 dB
Filter A	$> 27 \text{ dB}$	$> 30 \text{ dB}$
Filter B	$> 77 \text{ dB}$	$> 80 \text{ dB}$

Filter selection: manual or remote.

Zero offsetVoltage stability (at constant temperature): $< 10 \mu\text{V/week}$.Voltage temperature coefficient (0°C to 55°C) $< \pm 1 \mu\text{V}/^\circ\text{C}$.Current ($25^\circ\text{C} \pm 5^\circ\text{C}$): $< \pm 10 \text{ pA}$.Current temperature coefficient (0°C to 55°C): $< \pm 1 \text{ pA}/^\circ\text{C}$.Noise: $< 30 \mu\text{V}$ peak-to-peak (unfiltered). Peak-to-peak noise is less than $30 \mu\text{V}$ 95% of the time since the noise amplitude approximates a Gaussian distribution where the standard deviation (which is also the rms value) = $8 \mu\text{V}$.Maximum input voltage: Guard to Chassis: $\pm 500 \text{ V peak}$; Guard to Low: $\pm 200 \text{ V peak}$; High to Low: $\pm 1200 \text{ V peak}$.**3480A/B With 3484A Multifunction Unit****DC Voltage**

Same specifications as 3482A

Ohms, Option 042**Ranges**Full range display: 100.00 Ω ; 1000.0 Ω ; 10.000 k Ω ; 100.00 k Ω ; 1000.0 k Ω ; 10.000 M Ω .

Overrange: 50% on all ranges.

Range selection: manual, automatic or remote.

Automatic ranging: upranges at 140% of range; downranges at 10% of range.

PerformanceAccuracy: 90 days ($25^\circ\text{C} \pm 5^\circ\text{C}$, $< 95\% \text{ R.H.}$)1000 Ω thru 1000 k Ω ranges: $\pm(0.01\% \text{ of reading} + 0.01\% \text{ of range})$.100 Ω range: $\pm(0.02\% \text{ of reading} + 0.05\% \text{ of range})$.10 M Ω range: $\pm(0.1\% \text{ of reading} + 0.01\% \text{ of range})$.Temperature coefficient (0°C to 55°C)100 Ω thru 100 k Ω ranges: $\pm(0.0015\% \text{ of reading} + 0.0005\% \text{ of range}) \text{ per } ^\circ\text{C}$.1 M Ω , 10 M Ω ranges: $\pm(0.0035\% \text{ of reading} + 0.0005\% \text{ of range}) \text{ per } ^\circ\text{C}$.**Measuring speed****Response time (without range change, full scale step input)**100 Ω thru 100 k Ω ranges (no filtering): 1 ms. reads to within 1 count of final reading when triggered coincident with step input.1000 k Ω range (Filter A): 200 ms to within 1 count of final reading when triggered coincident with step input.10 M Ω range (Filter A): 2 s to within 1 count of final reading when triggered coincident with step input.Reading period: 950 μs .**Reading rate (without range change)**

Manual: reading may be manually initiated with front panel pushbutton.

Internal: 1 to 25 per s with front panel control.

External: 0 to 1000 per s with external trigger.

Input Characteristics

Voltage across unknown: 1 V at full scale, all ranges.

Current thru unknown100 Ω range: 10 mA; 1000 Ω range: 1 mA; 10 k Ω range: 100 μA .100 k Ω range: 10 μA ; 1000 k Ω range: 1 μA ; 10 M Ω range: 100 nA.Overload protection: $\pm 75 \text{ V peak}$, all ranges.**True RMS AC Voltage Option 043**

(condensed specifications)

Ranges

Full range display: 100.00 mV; 1000.0 mV; 10.000 V; 100.00 V; 1000.0 V.

Overrange: 50% on all ranges. 1500 V peak maximum input.

Range selection: manual, automatic or remote.

Automatic ranging: upranges at 140% of range; downranges at 10% of range.

PerformanceAccuracy (90 days, $25^\circ\text{C} \pm 5^\circ\text{C}$, $< 95\% \text{ R.H.}$)**AC coupled**100 mV, 1000 mV ranges: 10 Hz to 10 MHz: $\pm 0.1\%$ of reading at full scale, midband, degraded to $\pm 0.2\%$ at 10 Hz and $\pm 2\%$ at 10 MHz.10 V, 100 V ranges: 10 Hz to 1 MHz: $\pm 0.1\%$ of reading at full scale, midband, degraded to $\pm 0.2\%$ at 10 Hz and $\pm 0.4\%$ at 1 MHz.1000 V range: 10 Hz to 100 kHz: $\pm 0.1\%$ of reading at full scale, degraded to $\pm 0.2\%$ at 10 Hz.

DC coupled

All ranges

- DC: ±1% of reading at full scale.
- 1 Hz to 4 Hz: ±1% of reading at full scale.
- 4 Hz to 10 Hz: ±0.2% of reading at full scale at 10 Hz degraded linearly to ±1% at 4 Hz.
- 10 Hz to 10 MHz: same as AC Coupled specifications listed above.

Response

AC coupled function: responds to true rms value of AC coupled input signal.

Direct coupled function: responds to true rms value of DC and AC input signal.

Reading is $\sqrt{(DC)^2 + (AC \text{ rms})^2}$. An external 10 μF coupling capacitor can be used to remove the dc component and measure only the ac component to 1 Hz.

Function selection: manual or remote.

Measuring speed

Response time (step input of 10% to 100% of full scale without range change).

AC coupled: 1 s to within ±0.1% counts of final reading.

DC coupled: 15 s to within ±0.1% counts of final reading.

Reading period: 950 μs.

Reading rate

Manual: reading may be manually initiated with front panel pushbutton.

Internal: 1 to 25 per s with front panel control.

External: 0 to 1000 per s with external trigger.

Input Characteristics

Coupling: AC and Direct Coupled functions.

Input impedance

Front terminals: 300 nH in series with the parallel combination of 2 MΩ ±1% and 45 pF ±5 pF.

Rear terminals: 700 nH in series with the parallel combination of 2 MΩ ±1% and <70 pF.

Crest factor: 7:1 at full scale, 35 Hz and above, derated linearly to 2.2:1 at 5 Hz.

Maximum input voltage

AC coupled: 1500 V peak ac, 100 V dc (10 V dc on 100 mV range). DC + AC = 1500 V peak.

DC coupled: 1000 V rms max; DC + AC = 1500 V peak.

General Specifications

Mainframes, Plug-Ins And Options

DC Ratio 3480A/B Option 002

Displayed Ratio: display in all functions is proportional to the ratio of the input voltage to the external 10 V dc or 100 V dc reference voltage applied to rear-panel ratio terminals.

Accuracy (with respect to external reference voltage)

10 V or 100 V ±5% external reference: Same as basic instrument accuracy specifications.

10 V, 100 V + 5% to + 35% or Add ±0.02% of reading to 10 V, 100 V -5% to -13%: basic instrument accuracy specifications.

Input Characteristics (ratio reference terminals)

Input voltage: +10 V or +100 V (referenced to Low side of measurement).

Input resistance: 10 V ratio range: 100 kΩ ±1.5%.

100 V ratio range: 100 kΩ ±0.5%.

Ratio measurement selection: manual or remote.

Ratio range selection: manual

Remote Control

Remote controls are selected by application of a "Low" state (logical "0") to the remote control lines through a rear-panel connector.

State	Requirements
"Low" (logical "0")	0 V to +0.5 V (2 mA max.) or contact closure to ground thru <250 Ω.
"High" (logical "1")	+2.4 V to +5 V or removal of contact closure to ground.

Remote Control Lines

Encode (external trigger): initiates a measurement period. Actuated by application of "Low" state for >50 μs. Line must be in "High" state >50 μs before applying "Low" state. Minimum time between Encode commands: 1 ms.

Inhibit (interface Hold): disables front-panel Sample Rate control.

Ratio select: selects ratio measurement (if mainframe has the Ratio option).

Filter select (3482A, 3484A only): selects Filter A or Filter B; one line per filter.

Range select (3482A, 3484A only): selects measurement range; one line per range.

Function select (3484A only): selects measurement function; one line per function.

Program (3482A Option 021, 3484A Option 041 only)

Actuation (applying "Low" state for >50 μs) causes program commands (Function, Range, Filtering, etc.) to be entered and executed. Prevents changes in selected program when "High" state is applied for >50 μs. Does not affect operation of Encode line. A minimum of 1 ms must be allowed between Program and Encode commands.

Output Lines

State	Output Characteristics
"High" (logical "1")	+5 V, 6 kΩ source resistance.
"Low" (logical "0")	0 V to +0.5 V, 12 mA max. sink current

Output "High" and "Low" states will differ by at least 4 V if output load is 100 kΩ or greater.

Flag (print command)

Line remains "High" during reading period. Line changes to "Low" to indicate completion of reading period and remains "Low" until start of next reading period.

Program Flag (3482A Option 021, 3484A Option 041 only):

Line remains "Low" until Program is executed. Line then goes "High" upon execution, then "Low" after programming is completed (1 ms).

Non-isolated Remote Control

Non-isolated remote control is standard on the 3481A, 3482A, and 3484A.

Isolation characteristics

All control lines are referenced to a ground line which is electrically common with the measurement Low terminals. Floating measurements can be made only if the programming source can be floated. Common Mode Rejection may be degraded, however, if external instrumentation is connected to these lines.

Program storage

Sustained "Low" state on control lines required for maintaining selected controls (Filtering, Ranges, etc.). Lines not selected remain in "High" state.

Isolated Remote Control (3482A Option 021, 3484A Option 041)

Note: 3482A Option 021, 3484A Option 041 will operate only with 3480A/B mainframes equipped with Isolated Digital Output (Option 004). Isolated Remote Control for the 3481A is provided in the mainframe Isolated Digital Output option.

Isolation characteristics

All control lines are referenced to earth ground (instrument chassis). Instrument will make floating measurements and maintain all Normal and Common Mode Rejection specifications when control lines are programmed.

Program storage

Allows entry and storage of the selected program (except Encode) eliminating the need for sustained "Low" states on the selected control lines. Program is automatically protected from inadvertent change. Remote control line logic states are entered only when a "Low" state is applied to the Program line. Program Flag (output line) verifies receipt of program.

Digital Output Options

The **Digital Output Options** provide measurement data outputs in digital form for printer and systems applications. In addition, input lines are included to remotely control triggering of the 3480A/B.

Print command output: DC coupled.

Print level: 0 V, 12 mA max current sink.

Inhibit level: +5 V or +10 V, 6 k Ω source resistance. (5 V or 10 V level selected with internal slide switch).

BCD outputs

4 line BCD (1-2-4-8) "1" state positive, 8 columns of information: 5 columns for measurement magnitude.
2 columns for function and polarity.
1 Column for range.

BCD levels

Output data is represented by a "High" state (logical "1") as defined below.

State	Characteristics
"High" (logical "1")	+5 V, 6 k Ω source resistance
"Low" (logical "0")	0 V to +0.5 V, 12mA max. sink current

Output "High" and "Low" states will differ by at least 4 V if output load is 100 k Ω greater.

BCD reference levels:

Reference Level	Output Characteristics
Negative	0 V, 0 Ω source resistance
Positive	+5 V \pm 10%, 6.8 k Ω source resistance

Storage

BCD output levels for previous reading are held until beginning of next measurement period.

Input lines

Printer Hold-off: Application of "High" state (+6 V to +15 V) disables front-panel Sample Rate and Trigger controls.

Encode, Inhibit: Same as Remote Control Encode and Inhibit lines.

Non-isolated Digital Output (3480A/B Option 003)

Non-isolated Digital Output is available both as a factory-installed option (3480A/B Option 003) and field installable accessory (HP 11147A).

Isolation characteristics

Output data lines and input control lines are referenced to a ground line which is electrically common with the measurement Low terminals. Floating measurements can be made only if the printer, coupler, etc., connected to the data and input lines can be floated. Common Mode Rejection Characteristics may be degraded, however.

Isolated Digital Output (3480A/B Option 004)

Isolated Digital Output is available only as a factory-installed option (3480A/B Option 004) and must be ordered at time of initial purchase if the mainframe is to be used with a 3482A or 3484A equipped with Isolated Remote Control (3482A Option 021, 3484A Option 041).

Isolation characteristics

Output data lines and input control lines are referenced to earth ground (instrument chassis) and are well isolated from the measurement input terminals. Instrument will make floating measurements and maintain all Normal and Common Mode specifications when the data and control lines are utilized.

General

Operating Temperature: 0°C to 55°C.

Storage Temperature: -40°C to +75°C.

Warmup Time: DC voltage, Ohms: 1 hour. AC voltage: 1/2 hour

Power: 115 V or 230 V \pm 10%, 50 Hz to 400 Hz, 60 VA max (including plug-in, options, normal environment conditions).

Input Terminals: High, Low and Guard terminals on both front and rear panels of 3481A, 3482A and 3484A. Front/Rear selector switch on front-panel of plug-in. High and Low Ratio Reference Input terminals on 3480A/B rear panel. Low Ratio and Low Input terminals are electrically common.

Dimensions: 3480A: 8" wide, 6 3/32" high, 16" deep (203 x 155 x 406 mm); 3480B 16 3/4" wide, 3 3/8" high, 18 3/8" deep (425 x 86 x 467 mm).

Weight

3480A:	basic instrument:	11 lbs 12 oz (5,25 kg)
	including options:	12 lbs 8 oz (5,7 kg)
	shipping:	17 lbs (7,65 kg)
3480B:	basic instrument:	12 lbs 12 oz (5,71 kg)
	including options:	13 lbs 8 oz (6,15 kg)
	shipping:	18 lbs (8,1 kg)
3481A:	net weight:	2 lbs 11 oz (1,2 kg)
	shipping:	5 lbs (2,3 kg)
3482A:	basic instrument:	4 lbs (1,8 kg)
	including options:	4 lbs 4 oz (1,9 kg)
	shipping:	7 lbs (3,15 kg)
3484A:	basic instrument:	4 lbs 6 oz (1,97 kg)
	including all options:	6 lbs 2 oz (2,76 kg)
	shipping:	8 lbs (3,6 kg)

Accessories Furnished

3480A/B

HP part no. 5060-6033 (2) Extender Boards.

HP part no. 03480-84402 BCD Connector for Options 003 and 004.

HP part no. 03480-84401 Rack Mounting Kit (3480B only).

3482A

HP part no. 03482-84401 Service Tools and Spare Parts Kit.

HP part no. 11149-61601 Remote Control Cable for Option 021.

3484A

HP part no. 03482-84401 Service Tools and Spare Parts Kit.

HP part no. 11149-61601 Remote Control Cable for Option 041.

Accessories Available

HP 11146A: 3480A/B Computer Interface Kit. Price: \$1000.

HP 11148A: Plug-in Extender Cable for servicing all plug-ins with 3480A (not required for 3480B). Price: \$45.

HP 11149A: Remote control cable for all plug-ins (furnished as part of 3482A Option 021 and 3484A Option 041). Price: \$25.

Note: The following accessories add optional capabilities not included with the basic instrument. Optional capabilities which are not listed as accessories can be ordered only at the time of initial purchase. The Isolated Remote Accessory, HP 11151A, can be used only with the 3480A/B Option 004, which is not available as an accessory.

HP 11147A: Non-isolated Digital Output for 3480A/B. Price: \$200.

HP 11151A: Isolated Remote Control for 3482A, 3484A. (Same as 3482A Option 021 and 3484A Option 041). Price: \$200. (Use only with Mainframes having Option 004).

HP 11152A: Ohms Converter for 3484A (Same as 3484A Option 042). Price: \$200.

HP 11153A: True RMS AC Converter for 3484A. (Same as 3484A Option 043). Price: \$800.

Prices

HP 3480A 1/2 module main frame. Price: \$800.

HP 3480B full rack width main frame. Price: \$900.

Main frame options:

Option 002 DC Ratio **Price:** Add \$200.

Option 003 Digital Output **Price:** Add \$200.

Option 004 Isolated Digital Output **Price:** Add \$375.

HP 3481A Buffer Amplifier (includes single 10 V dc voltage range and non-isolated remote control). Price: \$350.

HP 3482A DC Range Unit (includes 5 ranges dc voltage and non-isolated remote control). Price: \$700.

Option 021 Isolated Remote Control (requires main frame with Opt 004, HP 11149A Remote Cable furnished). Price: Add \$200.

HP 3484A Multifunction Unit (includes 5 ranges DC voltage and non-isolated remote control). Price: \$900.

Option 041 Isolated Remote Control (requires main frame with Opt 004, HP 11149A Remote Cable furnished). Price: Add \$200.

Option 042 Ohms Converter. Price: Add \$200.

Option 043 True RMS AC Converter. Price: Add \$800.

Note: Options, not also listed above as **Accessories Available**, must be ordered with the instruments. Accessories may be purchased later.



Q METER

Measures Q, L, C, & resonant frequency
Model 4342A

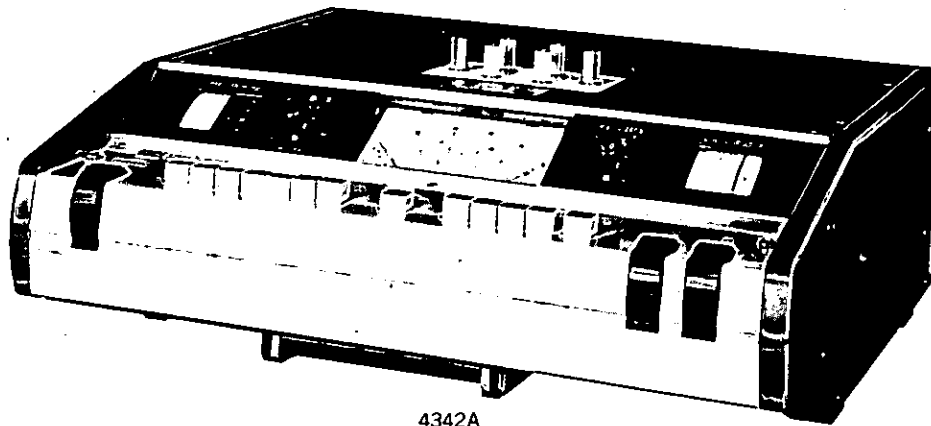

Description

The direct-reading expanded scale of the 4342A permits measurement of Q from 5 to 1000 and readings of very small changes in Q resulting from variation in test parameters. The 4342A is solid state with the elimination of specially matched, fragile thermocouple components.

The Q meter consists of a stable, continuously variable oscillator, with automatic level-control. The output is applied in series with an external unknown and an internal variable capacitor. A Q voltmeter with high input Z is connected across the internal variable capacitor portion of the tuned circuit to measure the reactive voltage in terms of circuit Q.

Usefulness

The 4342A will measure dissipation factor and dielectric constant of insulating materials. The Q meter can measure coefficient of coupling, mutual inductance, and frequency response of transformers. RF resistance, reactance, and Q of resistors and capacitors can also be determined.

Internal Oscillator

The internal oscillator covers a frequency range from 22 kHz to 70 MHz (10 kHz to 32 MHz in Option 001) in seven bands. This source is automatically leveled to provide a constant injection voltage. This ALC feature eliminates the Q multiplier control found on other Q meters.

4342A Q Meter

RF Characteristics

RF range: 22 kHz to 70 MHz in 7 bands: 22 to 70 kHz, 70 to 220 kHz, 220 to 700 kHz, 700 to 2200 kHz, 2.2 to 7 MHz, 7 to 22 MHz, 22 to 70 MHz.

RF accuracy: $\pm 1.5\%$ from 22 kHz to 22 MHz.
 $\pm 2\%$ from 22 MHz to 70 MHz.
 $\pm 1\%$ at "L" point on Frequency Dial.

RF increments: approximately 1% resolution.

Q Measurement Characteristics

Q range: 5 to 1000 in 4 ranges: 5 to 30, 20 to 100, 50 to 300, 200 to 1000.

Q accuracy: % of indicated value. (at 25°C)

Frequency

Q/Freq.	22 kHz - 30 MHz	30 MHz - 70 MHz
5 - 300	± 7	± 10
300 - 600	± 10	± 15
600 - 1000	± 15	± 20

Q Voltmeter

High stability of the Q Voltmeter eliminates Q-zero adjustment for routine measurements. Accurate information on changes in Q is obtainable on all Q-ranges through the greater resolution ($\times 10$) of delta-Q measurement.

Constant Voltage Injection System

The 4342A utilizes a Constant Voltage Injection System eliminating the fragile thermocouple system found in other Q meters. The low impedance of this injection system increases Q accuracy.

Rapid Inductance Measurement

A single "L" point on the frequency dial eliminates the necessity to readjust frequency during inductance measurements.

GO/NO-GO Q Selector

The Q-Limit selector will be especially useful for rapid Go/No-Go testing. The high response speed of the Go/No-Go indicator compared to the meter movement is an added feature. External devices may be remotely controlled by the Go/No-Go Over Limit signal.

Simple, Easier Operation

Push-button operation of Frequency Range and Q/ Δ Q Range selection provides straight forward measurement. Automatic indication of meter scales, frequency dials and frequency multipliers are featured, adding to simplicity and reading speed.

Specifications

Q increments: upper scale: 1 from 20 to 100, lower scale: 0.5 from 5 to 30.

Δ Q range: 0 to 100 in 4 ranges: 0 to 3, 0 to 10, 0 to 30, 0 to 100.

Δ Q accuracy: $\pm 10\%$ of full scale.

Δ Q increments: upper scale: 0.1 from 0 to 10, lower scale: 0.05 from 0 to 3.

Inductance Measurement Characteristics

L range: 0.09 μ H to 1.2 H, direct reading at 7 specific frequencies.

L accuracy: $\pm 3\%$ after substitution of residuals (approx. 10 nH).

Resonating Capacitor Characteristics

Capacitor range: main dial: 25 to 470 pF; vernier dial -5 to +5 pF.

Capacitor accuracy: main dial: $\pm 1\%$ or 1 pF, whichever is greater; vernier dial ± 0.1 pF.

Capacitor increments: main dial: 1 pF from 25 to 30 pF, 2 pF from 30 to 200 pF, 5 pF from 200 to 470 pF; vernier dial: 0.1 pF.

Rear Panel Outputs

Frequency monitor: 170 mV rms min. into 50 Ω .

Q analog output: 0 to 1 V \pm 50 mV dc after 15 minutes warm-up, proportional to meter deflection. Output impedance approximately 1 k Ω .

Over limit signal output: contact closure at the rear panel. Relay contact capacity 0.5 A/15 VA.

Over limit display time: selectable, 1 s or continuously on, after limit exceeded.

Temperature range: 0°C to 50°C.

Power: 115 or 230 V \pm 10%, 50-400 Hz, 25 Watts.

Dimensions: 16 $\frac{3}{4}$ " wide, 5 $\frac{1}{2}$ " high, 16 $\frac{1}{2}$ " deep (425 x 138 x 414 mm).

Weight: 31 lbs. (14 kg).

Price: Model 4342A, \$1500.

4342A Opt 001

(Changes from the standard specifications)

RF Characteristics

RF range: 10 kHz to 32 MHz in 7 bands: 10 to 32 kHz, 32 to 100 kHz, 100 to 320 kHz, 320 to 1000 kHz, 1 to 3.2 MHz, 3.2 to 10 MHz, 10 to 32 MHz.

RF accuracy: \pm 1.5% from 10 kHz to 10 MHz.
 \pm 2% from 10 MHz to 32 MHz.
 \pm 1% at "L" point on Frequency Dial.

Q Measurement Characteristics

Q accuracy: % of indicated value (at 25°C).

Q		
5 - 300	300 - 600	600 - 1000
\pm 7	\pm 10	\pm 15

Price: Model 4342A Opt 001, add \$100, to base price.

Accessories For Model 4342A Q Meter

Auxiliary Capacitor

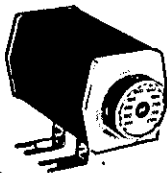

The 16462A Auxiliary Capacitor is designed to extend the Q and L measurement capability of the 4342A Q Meter. It is especially useful for measuring small inductors at low frequencies.

Specifications, 16462A

Capacitance range: 300 pF to 2700 pF in steps of 300 pF. 10 ranges including OFF position.

Capacitance accuracy: \pm 1% on all ranges.
 $Q \geq 10,000$ at 20 kHz on all ranges.

Residual inductance: approximately 0.1 μ H.

Residual capacitance at off position: approximately 23 pF.

Price: HP 16462A, \$150.

Series Loss Test Adaptor

The 16014A Series Loss Test Adaptor is designed for measuring low impedance components, low-value inductors and resistors, and also high-value capacitors. Using the adaptor adds convenience in connecting components in series with the test circuit of the 4342A Q Meter. This adaptor consists of a Teflon printed-circuit base on which are mounted binding posts, to accept the Reference Inductors, and a pair of low-inductance series terminals for the unknown.

Specifications, 16014A

Usable frequency range: 10 kHz to 10 MHz.

Measurable capacitance range: 450 pF to 0.225 μ F.

Measurable resistance range: 4 Ω to 8 k Ω at 10 kHz. 10 m Ω to 80 Ω at 10 MHz.

Equivalent parallel capacitance between unknown terminals: 3 pF.

Equivalent parallel resistance between unknown terminals: approximately 10 M Ω at 1 MHz.

Residual inductance: approximately 30 nH.

Price: HP 16014A, \$35.

Reference Inductors



A range of 20 inductors, any of which can be supplied separately, is available for use with the 4342A Q Meter for measuring the RF characteristics of capacitors, resistors, and insulating materials. These inductors have 3 terminals. One terminal is connected to the case to stabilize measurements.

Specifications, 16471-16490A, 16465A

Model	Inductance	Approx. resonant frequency for tuning capacitance of			Approx. Q.	Capacitance pF
		400 pF	100 pF	50 pF		
16471A	130 mH	22	40	62 kHz	270	8
16472A	52 mH	35	70	100 kHz	270	8
16473A	25 mH	50	100	140 kHz	270	8
16474A	10 mH	80	160	220 kHz	270	8
16475A	5.2 mH	110	220	300 kHz	270	8
16476A	2.8 mH	150	300	420 kHz	270	8
16477A	1 mH	250	500	700 kHz	270	8
16478A	520 μ H	350	700	1000 kHz	270	8
16479A	250 μ H	500	1000	1400 kHz	270	7
16480A	100 μ H	800	1600	2200 kHz	270	7
16481A	56 μ H	* 1	2.2	3.1 MHz	270	7
16482A	28 μ H	1.5	3	4.2 MHz	270	7
16483A	10 μ H	2.5	5	7 MHz	270	6
16484A	5.2 μ H	3.5	7	10 MHz	270	6
16485A	2.5 μ H	5	10	14 MHz	270	6
16486A	1 μ H	8	16	22 MHz	270	6
**16465A	630 mH	10	20	28 kHz	270	9
		100 pF		35 pF		
16487A	0.52 μ H	22 MHz		35 MHz	270	6
16488A	0.28 μ H	30 MHz		50 MHz	270	4
16489A	0.1 μ H	50 MHz		70 MHz	250	3
16490A	0.07 μ H	60 MHz		100 MHz	250	2

*Approximate resonant frequency for tuning capacitance of 450 pF.

**For 4342A option 001 use only.

Prices: HP 16471A through HP 16490A, and HP 16465A, \$25 each.

HP 16470A set of twenty (16471A-16490A), \$500.

Q Standards

The 00513A and 00518A Q standards are hermetically sealed reference inductors having accurately measured, highly stable inductance and Q characteristics. These Q standards are particularly useful for checking the overall operation and accuracy of Q-meters. The 00513A/00518A series must be used in conjunction with appropriate correction factors given in the Model 4342A Instruction Manual.

Specifications, 00513A, 00518A

Model	00513-A	00518-A1	00518-A2	00518-A3	00518-A4	00518-A5
Inductance	250 μ H	0.25 μ H	2.5 μ H	25 μ H	2.5 mH	25 mH
Low-freq. data: Frequency	0.5 MHz	15 MHz	5 MHz	1.5 MHz	150 kHz	50 kHz
Resonating C	400 pF	420 pF	395 pF	440 pF	440 pF	400 pF
Indicated Q	183	175	195	175	170	90
Middle-freq. data: Frequency	1 MHz	30 MHz	10 MHz	3 MHz	300 kHz	100 kHz
Resonating C	100 pF	100 pF	95 pF	105 pF	100 pF	85 pF
Indicated Q	234	235	235	225	180	130
High-freq. data: Frequency	1.5 MHz	45 MHz	15 MHz	4.5 MHz	450 kHz	150 kHz
Resonating C	50 pF	40 pF	40 pF	45 pF	40 pF	35 pF
Indicated Q	200	225	205	230	135	125

Prices: HP 00513A, HP 00518A, \$125. each ; set of one HP 00513A and five HP 00518A, \$675.



PSOPHOMETER

Measures transmission level and noise
Model 3556A

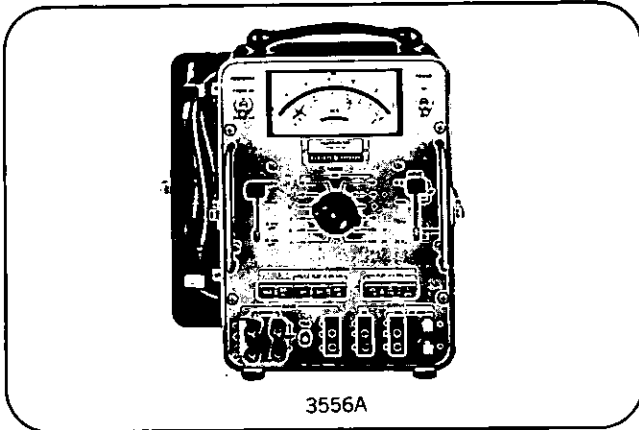

Description

The 3556A Psophometer has been designed to combine the features of an accurate level meter with a noise meter including the psophometric weighting filters adopted by the CCITT in 1960 and reviewed in 1964 and 1968. It, with the 236A option H10 Telephone Test Oscillator, makes a complete Transmission Test Set.

The 3556A measures transmission gain, loss, crosstalk coupling, metallic noise and noise to ground. Built-in Telephone and Program filters, according to CCITT recommendation, 15 kHz and 3 kHz low-pass filters and a 3 MHz bandwidth adapt this instrument to carrier and voice frequency level measurements as well as noise measurements.

Input impedances are 150 and 600 ohms symmetrical and 75 ohm asymmetrical, terminated. 15 k ohm symmetrical and 100 k ohm asymmetrical are non-terminated input impedances. The rms meter response of 200 and 500 ms is supplied to simulate the human ear's response. All these characteristics make this instrument an ideal transmission measuring set where CCITT standards are adopted.

Specifications

Voice frequency level measurements (Flat input < 20 kHz functions)

Voltage range: 0.1 mV to 30 V full scale, 12 ranges, in a 1, 3 sequence; dBm range: -78 dBm to +32 dBm full scale, 12 ranges.
Frequency range: 20 Hz to 20 kHz.
Level accuracy: 100 Hz to 5 kHz: ± 0.2 dB.
20 Hz to 20 kHz: ± 0.5 dB.

Input

Terminated: 600 Ω symmetrical
Return loss: 30 dB min. (50 Hz to 20 kHz)
Non-terminated: > 15 k Ω symmetrical
Non-terminated error: < 0.4 dB at 800 Hz.
Symmetry: > 80 dB at 50 Hz, > 70 dB to 6 kHz, > 50 dB to 20 kHz.
Holding circuit (available only on 600 Ω , a/ \oplus and b/ \oplus): 700 Ω dc resistance, 60 mA max loop current at 300 Hz. With the holding circuit in, above specs apply from 300 Hz to 4 kHz.

Noise measurements

(Filtered input < 20 kHz functions)

Voltage range: 0.1 mV to 30 V full scale, 12 ranges, in a 1, 3 sequence.
dBm range: -78 dBm to +32 dBm full scale, 12 ranges.
Weighting filters: telephone and program weighting curves meet joint requirements of CCITT Psophometric Recommendation P53.

3 kHz low-pass filter. 15 kHz low-pass filter.

Input: Terminated: 600 Ω symmetrical.

Non-terminated: > 15 k Ω symmetrical.

a/ \oplus and b/ \oplus : > 100 k Ω from each side to ground (40 dB attenuation).

Symmetry: exceeds the CCITT balance requirement.

Carrier frequency level measurements (Flat input > 1 kHz functions)

Voltage range: 3 mV to 3 V full scale, 7 ranges, in a 1, 3 sequence; dBm range: -48 dBm to +12 dBm full scale, 7 ranges.

Frequency range: 30 Hz to 3 MHz.

Level accuracy

600 Ω symmetrical: 1 kHz to 150 kHz: ± 0.5 dB; 10 kHz to 100 kHz: ± 0.2 dB.

150 Ω symmetrical: 1 kHz to 600 kHz: ± 0.5 dB; 10 kHz to 300 kHz: ± 0.2 dB.

75 Ω asymmetrical: 100 Hz to 600 kHz: ± 0.2 dB; 30 Hz to 1 MHz: ± 0.5 dB; 1 MHz to 3 MHz: ± 0.5 dB $\pm 10\%$ of meter reading.

Input

Terminated: 150 Ω , 600 Ω symmetrical, 75 Ω asymmetrical.

Return loss: 600 Ω : 3 kHz to 150 kHz, 26 dB min; 150 Ω : 1 kHz to 600 kHz, 26 dB min; 75 Ω : to 3 MHz, 30 dB min.

Non-terminated: > 15 k Ω symmetrical, 100 k Ω asymmetrical.

Non-terminated loss: < 0.05 dB at 10 kHz. Symmetry: > 70 dB to 10 kHz; > 60 dB to 100 kHz; > 40 dB to 600 kHz.

General

Meter reading: linear dBm scale with 12 dBm range and logarithmic voltage scales with 1, 3 sequence, indicate rms value of input signal. dBm scale is valid on 600 Ω and 150 Ω impedances, voltage scales are valid on 600 Ω and 75 Ω impedances.

Meter response: 200, 500 ms to indicate readings from -10 to 0 dBm.

Max input voltage: a to b: 150 V peak, a or b to \oplus : 500 V peak.

Protection against electric and magnetic interfering fields: exceeds the CCITT requirement by 20 dB.

Input jacks: Siemens 9 REL KLI-6A (accepts 4 mm diameter banana plugs or mating 3 prong Siemens 9 REL STP 6AC connector). Standard banana jack; BNC (75 Ω asymmetrical).

AC monitor: 0.23 V rms for 0 dBm on meter. R out = 8 k Ω , available at Dial/AC Monitor jacks. Sufficient to drive a handset or earphone.

DC monitor: 1 V open circuit or 390 μ A short circuit current for 0 dBm on the meter.

Note:

AC/DC monitor jacks accept Siemens 9 REL STP 6AC connectors.

Power requirements

HP Model 3556A Standard: 4 rechargeable batteries (25 V total) or power line from 90 V ac to 250 V ac (without switch), 48 Hz to 440 Hz, < 10 VAW during battery charge.

HP 3556A Option 001: Internal dry battery: single 45 V "B" battery furnished. Battery life: 180 hrs at 4 hr/day.

External battery: -24 V to -48 V office battery, < 15 mA.

AC: 115 or 230 V (switch), 48 Hz to 440 Hz, < 10 VAW.

Temperature range: -15°C to +50°C.

Dimensions: 197 mm wide, 299 mm high, 207 mm deep (7 $\frac{3}{4}$ " x 11 $\frac{3}{4}$ " x 8 $\frac{1}{8}$ ").

Weight: net 6.8 kg (15 lb); shipping 7.5 kg (17 lb).

Complementary Equipment Available: HP Model 236A Opt H10 Telephone Test Oscillator. Refer to page 61 in this Supplement.

Price: HP 3556A (ac line and rechargeable battery) \$800. HP 3556A Option 001 (ac line, internal battery, external supply) \$775.

(Operating instructions printed in protective cover in English supplied. Also available at no charge in German, Opt. 002; Italian, Opt. 003; French, Opt. 004; Spanish, Opt. 005; Portuguese, Opt. 006; Dutch, Opt. 007; Finnish, Opt. 008.

SPECIFIC SIGNAL SOURCES

Added single & multicycle; Telephone Test Osc.
Models 3310A, Option H10; 236A, Option H10



SIGNAL SOURCES

3310A Opt H10 Function Generator

The 3310A Opt H10 has all the features of the standard 3310A (page 273 in the 1970 Catalog) plus single and multiple cycle output capability. With the start/stop phase knob in the detent position (max ccw) the instrument has the same specifications as the standard 3310A. When the start/stop phase knob is out of the detent, single or multiple cycle outputs can be obtained using either manual or external triggering. The start/stop phase knob will vary the phase at which the single or multiple cycle output starts and stops, and an integral number of cycles is always generated.

When properly triggered, the 3310A Opt H10 can generate many useful waveforms. Some of these are: 1) variable duty cycle rectangular functions, 2) variable slope ramps, 3) tone bursts with FM inside the burst by using VCO input and EXT Gating at the same time, and 4) the output is phase coherent with input; phase relationship of the output is variable from -90° to $+90^\circ$ with the input.

The 3310A Opt H10 is an inexpensive solution to generating many types of waveforms.

3310A Opt H10 Specifications

(In addition to the 3310A specifications)

Modes of operation: single cycle; multiple cycle

Frequency range: 0.0005 Hz to 1 MHz (usable to 5 MHz)

Single cycle: EXT TRIGGER (AC coupled) requires a positive-going square wave or pulse from 1 V p-p to 30 V p-p of a lower frequency than that set on the 3310A; the triggering signal can be dc offset, but $(V_{ac\ peak} + V_{dc}) \leq \pm 30$ V.

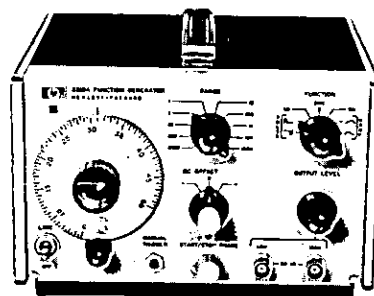

3310A Opt H10

Multiple cycle: MANUAL TRIGGER will cause the 3310A to free run when depressed. When the trigger button is released, the waveform will stop on the same phase as it started. EXT GATE will cause the 3310A to free run when the gate input is held at between +1 and +30 V. When the gate signal goes to zero volts or negative the 3310A will stop on the same phase as it started. For accurate gating, a square wave or square pulse is recommended.

Start-stop phase: the start-stop phase can be adjusted over a range of approximately $\pm 90^\circ$ using the front panel control.

Input impedance EXT GATE: 500 Ω . EXT TRIGGER: 390 pF in series with 500 Ω

Price: 3310A Opt H10, \$735.

Reference: Hewlett-Packard Journal Article (3310A) June 1969.

Model 236A Opt H10 Telephone Test Oscillator

The 236A option H10 is a special version of the 236A Test Oscillator (page 431 of the 1970 General Catalog), to be used with the 3556A Psophometer. These two instruments make a complete Telephone Transmission measuring set designed for telephone maintenance both in the plant and in the field.

236A Opt. H10 Specifications

Frequency range: 50 Hz to 560 kHz.

Frequency dial accuracy: $\pm 3\%$ of setting.

Frequency response (15°C to 27°C operating temperature):*

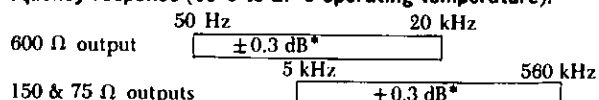

Output level: -31 dBm to +10 dBm in 0.1 dBm steps.

Output level accuracy: ± 0.2 dBm from -31 dBm to +10 dBm (800 Hz reference), when operating into selected output impedance.

Distortion: at least 40 dB below fundamental output.

Noise: ≥ 65 dB below full output or -90 dBm, (the greater).

Output impedance: 600 $\Omega \pm 5\%$; 150 $\Omega \pm 10\%$; 75 $\Omega \pm 10\%$.

Output symmetry: 70 dB at 100 Hz; 55 dB at 3 kHz (600 Ω output); 50 dB at 5 kHz; 30 dB at 560 kHz (150 Ω output).

Output jacks: accepts 3 prong Siemens 9 REL STP 6AC or 4 mm diameter banana plugs. Binding post accept banana plugs, spade lugs, phone tips or bare wires. Removable shorting bar between c terminal and ground binding posts.

Dial jacks: accepts 3 prong Siemens 9 REL STP 6AC or 4 mm diameter banana plugs. Clip posts accept lineman's handset clips, such as alligator clips.

DC holding coil: 700 $\Omega \pm 10\%$ dc resistance; 60 mA maximum loop current at 100 Hz (600 Ω output only).

*Response is ± 0.5 dB from 0°C to 15°C and 27°C to 50°C.

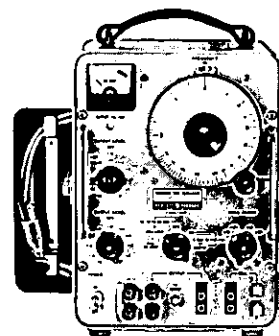

236A Opt H10

Power requirements

Line: 115 or 230 V (switch) $\pm 10\%$ ac, 48 Hz to 440 Hz, 1 W.

Internal battery: single NEDA 202 45 V "B" battery furnished.

Battery life: expected life 180 hrs at 4 hrs per day.

Dimensions: 197 mm wide, 299 mm high, 207 mm deep. (7 $\frac{3}{4}$ " x 11 $\frac{1}{4}$ " x 8 $\frac{1}{8}$ ").

Weight: net (6.1 kg) 13.5 lbs; shipping (7.2 kg) 16 lbs.

Complementary equipment available: HP Model 3556A Psophometer.

Refer to page 60 in this Catalog Supplement.

Price: HP 236A Opt H10, \$650.

(Operating instructions printed in the protective cover in English supplied; also available at no charge in German, Option 002; in Italian, Option 003; in French, Option 004; and in Spanish, Option 005).

SWEEPERS



SWEEP OSCILLATOR

Solid State, Self-Contained System to 18GHz
Series 8620

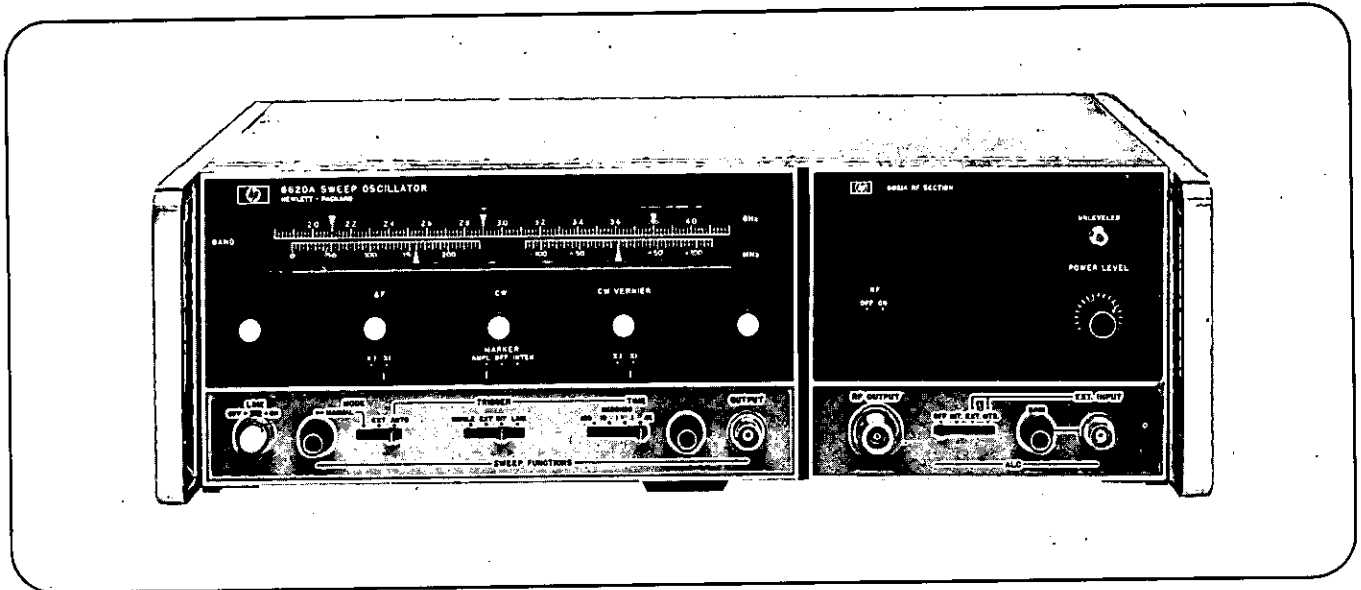

The 8620A, a compact, self-contained, all solid state, multiband sweeper system.

Flexibility For Wide-Band And Narrow-Band Swept Measurements

The new 8620 Sweep Oscillator System is a self-contained multiband, all solid-state sweep system which offers economy as well as ease of use as a swept signal source for both wide-band and narrow-band swept measurements. To achieve this in a small, lightweight, portable instrument without the sacrifice of performance, Hewlett-Packard developed ultra reliable microelectronic circuits for miniature oscillators, modulators, couplers, detectors and filters.¹ The result is a sweep oscillator which is portable enough for field use and also offers increased performance and flexibility for precision wide-band or narrow-band laboratory applications.

Self-Contained, Multiband Capacity Using Wider Than Octave Coverage Oscillators For Wide-Band Measurements

On the right of the 8620A Sweep Oscillator Mainframe is located the 8621A RF Section which is a convenient plug-in drawer. This drawer serves as a shell for RF modules such as oscillators and attenuators. Because of its modular design, one can start a system with a single oscillator in the drawer for single-band performance and economy. Then when needs grow for multiband performance, additional oscillators and other RF modules can be added without the necessity to purchase extra, separate units. The designed-in multiband capacity of the 8620 system doesn't require these separate units—specifically, RF unit holders, control units and multiplexers. They have already been incorporated in the multiband 8621A RF Drawer. Full RF drawer capacity consists of two wider than octave frequency range fundamental-type oscillator modules, a wider than decade frequency range heterodyne oscillator module and 70 dB programmable attenuator. All of the above units in a full capacity system are fully multiplexed and self-contained in the drawer. With a touch of the band switch lever just to the left of the dial scale, the

proper oscillator scale is rotated into position while completing all dc, RF and leveling switching necessary between modules in the drawer. This represents a truly convenient wide-band capacity, one which doesn't necessitate changing plug-ins or the addition of costly, bulky, additional instruments to make wide-band swept measurements.

Self-contained, multiband oscillator capacity coupled with a convenient method for switching between bands contributes two of three important characteristics for wide-band swept measurements. The third characteristic necessary is a good approach to making sure no swept frequency information is lost where one must change bands. Hewlett-Packard's 8620 system oscillator modules, Series 8630, solve this problem by offering wider than octave coverage or band overlap. For example, as pictured above, our standard 2 to 4 GHz module is specified over a 1.8 GHz to 4.2 GHz range and the dial scale is so marked. This assures an 8620 owner that he will never have any doubt about his design's wide-band swept frequency performance at the band break points of 2 GHz and 4 GHz.

Excellent stability, low-residual FM, and good sweep linearity are contributed by the choice of oscillators for the 8620A. Our YIG oscillators use transistors or bulk effective devices as active elements and YIG (Yttrium Iron Garnet) spheres as frequency determining elements. The YIG sphere is extremely high Q and therefore, contributes stability as the frequency determining element. Its resonant frequency is a linear function of current and therefore doesn't require the extensive shaping networks commonly associated with BWO or varactor-tuned oscillators. Low-residual FM in CW and sweep modes is achieved through high stability, all solid-state power supplies.

Continuously Calibrated ΔF Sweep For Precision Narrow-Band Measurements

Excellence in narrow-band swept frequency measurements depends on two important features attributable to the source. First, a convenient method of pin-pointing and expanding the portion of a wide-band sweep that is of interest for narrow-

¹ See Hewlett-Packard Components Catalog.

band consideration is necessary. Second, a continuously variable, fully calibrated direct reading dial scale for use in narrow-band sweep should be available.

The first feature, a convenient and accurate ability to switch between wide-band and narrow-band sweeps, is facilitated in the 8620A through a unique sweep mode selection scheme. This sweep mode selection technique positively identifies the sweep mode in use and the frequency controls that set the frequencies. Pushbuttons concentrically located in the frequency control knobs, light when actuated to indicate the sweep mode in use. As such, they also indicate the frequency controls to be utilized in setting frequencies. For example, the wide-band START/STOP mode is selected by actuating either the START or STOP buttons in their respective frequency control knobs. Both knobs light to indicate both controls are in use.

In the START/STOP sweep mode a marker is available. It may be either an intensity marker where the Z axis of the CRT display is modulated to produce a bright spot or it may be an amplitude marker which causes a sharp dip in the RF output power. The marker is selected and its frequency controlled by the CW knob and switch below. The marker is of the constant width type, i.e., it always occupies the same percentage of the display even with reduced sweep widths. Therefore, even in narrow START/STOP sweeps it doesn't lose accuracy because it is too wide.

To conveniently change from the wide-band START/STOP sweep to the narrow-band ΔF sweep, we employ this marker. The marker is set on the discontinuity of interest in the START/STOP mode. When ΔF sweep is actuated, the ΔF control, which controls the ΔF sweep width, lights along with the CW control. The CW control lights because it sets the center frequency of ΔF sweeps. When switching from START/STOP to ΔF , the marker at the center of the discontinuity in START/STOP becomes the center frequency of the ΔF sweep. Thus, the discontinuity is automatically centered when changing from the wide-band START/STOP sweep to the narrow-band ΔF sweep. Now all that remains to be done is to select an appropriate sweep-width that optimizes the display.

A continuously-variable ΔF sweep width allows optimum display of the frequency response. One does not lose display accuracy because only fixed width ΔF positions are fully calibrated. The 8620 is fully calibrated for any ΔF sweep width. Having chosen an optimum width, one can read the total sweep width from the calibrated dial scale just above the ΔF knob and to the left, below the main dial scale. Note that two continuously variable ΔF widths are available by using the range switch below the ΔF knob. This allows calibrated dial scale presentations of sweep widths of up to 1% or 10% of full band at the users choice.

When sweeping very narrow-band, less than 1%, the CW knob, which controls the center frequency, will feel coarse to the touch. One should then engage the CW vernier control for more convenient setting of the ΔF sweep center frequency. With the CW vernier engaged, the center frequency of ΔF sweep is read as the sum of the frequency set with main dial scale CW control and the incremental value set on the fully calibrated, CW vernier dial scale. Using the CW vernier control in this manner results in a smooth action with which to set the center frequency on the narrowest of sweeps. Its operation is identical to its function as explained under Signal Generator Applications.

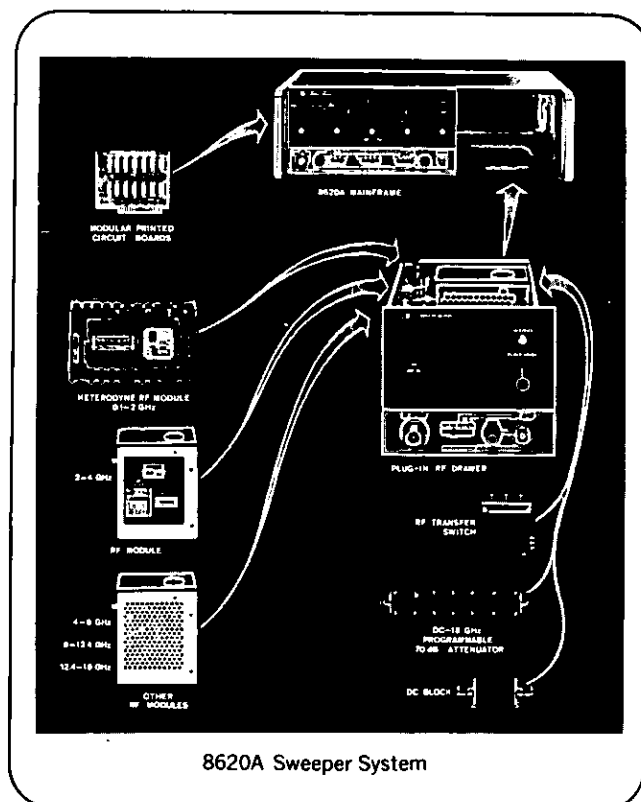

Signal Generator Applications

Besides swept measurements, the 8620A is well-suited for tests requiring signal simulation. The inherent stability and high-spectral purity of the 8620A's Solid-State Oscillators, plus the versatile modulation format, commend the sweeper for such applications. Both the AM and FM functions can be employed simultaneously to simulate complex modulation schemes.

The CW mode is selected by depressing the CW knob. It is possible to also engage the CW vernier knob to achieve very accurate setability. With the uniquely-shaped main dial scale cursor placed on any convenient mark, it is possible to accurately interpolate between dial scale markers by utilizing the CW vernier. This vernier makes the effective length of the dial scale extremely long and contributes to the increased setability.

A signal generator has two basic characteristics that most sweepers don't have: wide dynamic power range and high-frequency stability. Both of these features are available in the 8620 Sweeper System. As the system pictured above shows, one can order a precision 70 dB attenuator as optional equipment installed in the Model 8621A RF Drawer, Option 010. The basic frequency stability of the 8620A Series is generally satisfactory for many applications. Stabilities achieved by precision reference oscillators (up to 10^{11}) can be transferred to the 8620A by operating in the phase-lock mode. Interfacing is achieved with the fully-compatible HP 8709A Synchronizer.

Other Features And Ordering

The 8620A offers many features as standard equipment. For example, 1) both normally-open and normally-closed penlift

SWEEPERS *continued***Solid State, Self-Contained System to 186Hz
Series 8620**

signals are available for X-Y recorder operation, 2) a phase-lock input for locking to reference oscillators has been supplied, 3) a power meter leveling input is available on the front panel (HP 431 and HP 432 Series Power Meters), 4) either polarity crystal leveling may be selected by a switch just inside the drawer and 5) an RF off switch on the front of the drawer allows quick calibration of zero power without disconnecting the equipment. Optional features include full BCD frequency programming on the Model 8620A Mainframe. Complete information is available from the data sheet. Be sure when ordering to specify a complete system that consists of at least an 8620A, an 8621A RF Drawer and one of the 8630 Series fundamental-type Oscillator Modules.

Specifications**8620A Sweep Oscillator****(With RF Units and Drawer Installed)****Frequency**

Frequency Range: Determined by band switching leveler and RF oscillator modules installed in 8621A drawer.

Frequency Linearity: Refer to RF unit specifications.

Sweep Functions

START/STOP Sweep: Sweeps from START TO STOP frequency setting. Selected by depressing either START or STOP frequency buttons on the front panel.

Range: Both settings continuously and independently adjustable over the entire frequency range; can be set to sweep either up or down in frequency.

End-point Accuracy: Refer to RF unit specifications, same as frequency accuracy.

ΔF Sweep: Sweeps upward in frequency, centered on CW setting. CW Vernier can be activated for fine control of center frequency.

Width: Continuously adjustable from zero to 1% or zero to 10% of usable frequency band as selected with front-panel switch. Scale calibrated directly in MHz.

Width Accuracy: $\pm 1\%$ of maximum ΔF plus $\pm 2\%$ of ΔF being swept.

Center-Frequency Accuracy: Refer to RF unit specifications, same as frequency accuracy.

Frequency Marker: The frequency marker is independently adjustable over the entire frequency range and set with the CW/Marker control. Front panel switch provides for the selection of either-amplitude or intensity markers (amplitude modulation the RF output or Z-axis modulation the CRT display).

Accuracy: Refer to RF unit specifications, same as Frequency Accuracy.

Resolution: Better than 0.25% of RF unit bandwidth.

Marker Output: Available from Z-axis output jack in rear (BNC). Rectangular pulse, typically -5V peak. Source impedance, 1000 ohms.

CW Operation: Single-frequency RF output selected by depressing pushbutton in CW/Marker control.

CW Vernier: Calibrated direct in MHz about CW setting. CW Vernier activated by pushbutton in CW Vernier control: $\pm .5\%$ or $\pm 5\%$ of full bandwidth selectable with front-panel switch.

Accuracy: Refer to RF unit specifications, same as frequency accuracy.

Preset Frequencies: Start-stop sweep end points and CW frequency can be used as three preset CW frequencies.

Sweep Modes

Auto: Sweep recurs automatically.

Manual: Front-panel control provides continuous manual adjustment of frequency between end frequencies set in any of the above sweep functions.

Triggered: Sweep is actuated by front-panel switch, or by externally applied signal $> +2$ V peak, $> \frac{1}{2}$ μ s pulse width, and < 1.0 MHz repetition rate. (Signal applied to external trigger input at rear panel BNC connector.)

Sweep Time: Continuously adjustable in four decade ranges, 0.01 to 100 seconds. Can be synchronized with the power-line frequency, front panel switch.

Sweep Output: Direct-coupled sawtooth, zero to approximately +10V, concurrent with swept RF output. Zero at start of sweep, approximately +10V at end of sweep regardless of sweep width or direction. In CW mode dc output is proportional to frequency. Source impedance approximately 10,000 ohms.

Modulation

Internal AM: Square-wave modulation internally adjustable from approximately 950 to 1050 Hz on all sweep times. On/off ratio greater than 20 dB at rated output.

External AM:

Frequency Response: dc to 100 kHz unlevelled, dc to 50 kHz levelled at rated output.

Sensitivity: Refer to RF unit specifications.

Input Impedance: Approximately 5000 ohms.

External FM: Refer to RF unit specifications.

Phase-lock: Refer to RF unit specifications.

General

Blanking: With blanking switch enabled, RF automatically attenuated during retrace, and turned on after completion of retrace. On automatic sweeps, RF is on long enough before sweep starts to stabilize external circuits and equipment whose response is compatible with the selected sweep rate.

Blanking Output: Direct-coupled rectangular pulse approximately +6.0V coincident with RF blanking available from Z-axis output jack in the rear. Source impedance approximately 1000 ohms.

Pen Lift: For use with X-Y graphic recorders. Penlift terminals available at programming connectors either shorted during sweep and open during retrace or open during sweep and shorted during retrace. Available only on slowest sweep speed.

Remote Band Select: Frequency range can be controlled remotely by three binary contact closure lines available at the programming connector.

Furnished: 7½ foot (2290 mm) power cable with NEMA plug; rack-mounting kit; accessory kit.

Power: 115 or 230 volts $\pm 10\%$, 50 to 400 Hz. Approximately 140 watts.

Dimensions: 5¼ in. (133,4 mm) high, 11 in. (279,4 mm) deep, 16¼ in. (425,5 mm) wide.

Weight: (not including RF modules or drawer): Net, 25 lb (11,5 kg). Shipping, 30 lb (13,7 kg).

Price: Model 8620A \$1,450.00

SWEEPERS *continued*

Solid State, Self-Contained System to 186Hz
Series 8620

Option 001 Remote Frequency Programming

Function:**Enable:** 1-line binary.**Frequency Select:** 1000 points, 12-line BCD.**Sweep Function:** Automatically in CW mode during remote programming.

Logic: 5-volt positive logic or remote contact closure.
Price: Option 001, add \$500.00

*For sweep durations ≤ 30 msec width accuracy is $\pm 1\%$ of maximum $\Delta F \pm 6\%$ of ΔF being swept.

Model 8621A RF Drawer

The basic RF drawer (without any options) is configured to accept one fundamental oscillator or one fundamental oscillator working with its associated heterodyne oscillator. There are also three options available for the drawer that can be ordered initially installed or installed later as needed. All options have plug-in connectors for electrical connections and a minimum number of mechanical connections. Any combination of options can be used together and the drawer can be up-dated later to accept other options (see Operating and Service Manual for instructions).

RF drawer and option specifications can be found below. RF power output depends on the drawer configuration used and the options included. The table below gives the insertion losses due to optional RF drawer components. To find the output power available at the RF output connector for any RF drawer configuration and for any oscillator, subtract the insertion loss figure (in dB) in the table below from the power rating (in dBm) shown in the 8630 Series RF Oscillator Specifications.



Specifications

Model 8621A RF Drawer

Frequency Range: Up to 18 GHz.**Oscillator Capacity:** One fundamental oscillator or one fundamental oscillator and heterodyne converter. Multiplexing for this capacity, supplied standard.**Reference Output:** Direct-coupled voltage proportional to RF frequency, compatible with HP 8410A Network Analyzer. Output impedance, approximately 1000 ohms.**FM Input (on rear panel):****Frequency Response:** Refer to RF unit specifications.**Leveling Indicator:** Front-panel indicator lights when power level set too high to permit leveling over entire selected sweep range or when operating in unleveled mode.**Equivalent Source Match:****Externally Leveled:** Depends on coupler.**Unleveled:** Less than 2.5:1**Internally Leveled:** Less than 1.6:1**Power Leveling Amplifier:** Internal dc-coupled leveling amplifier provided.**Crystal Input:** Approximately -20 to -350 mV for specified leveling at rated output; for use with positive or negative polarity detectors such as 780 Series Directional Detectors, 423A and 424 Series Crystal Detectors. Polarity switch provided in RF drawer.**Power Meter Input:** Switch in RF drawer selects proper compensation for Hewlett-Packard Models 431B, 431C, and 432A.**Weight:** Net 3 lb (1,5 kg).**Price:** Model 8621A, \$300.00

Option 100

Oscillator Capacity: Two fundamental oscillators and one heterodyne converter. Multiplexing for this capacity, supplied standard with this option.

All Other Specifications: Same as 8621A above.
Price: Option 100, add \$400.00.

Option 010, 70-dB Attenuator

Attenuation Range: 70 dB in 10 dB steps.**Attenuation Accuracy (including frequency response):****Up to 12.4 GHz:** Less than $\pm 3\%$ of attenuation used.**12.4 to 18 GHz:** Less than $\pm 5\%$ of attenuation used.**Programming Inputs:** 4-line binary, 5-volt logic or contact closure, available at 8620A programming connector.**Weight:** Net, 2 lb (1,0 kg).**Price:** Option 010, add \$650.00.

Option 004, Rear RF Output

Connector: Type N**Price:** Option 004, add \$75.00.

INSERTION LOSSES FOR 8621A RF DRAWER AND OPTIONS*			
Options Included in 8621A RF Drawer		Insertion Loss Due to Optional RF Drawer Components	
Multiband Config- uration Option 100	70 dB Attenuator Option 010	Up to 12.4 GHz	12.4 to 18 GHz
Yes	No	0.8 dB	1.1 dB
No	Yes	1.0 dB	1.0 dB
Yes	Yes	1.8 dB	2.1 dB

*Option 004, Rear Output, No Insertion Loss.

SWEEPERS *continued*

Solid State, Self-Contained System to 18GHz
Series 8620

Specifications: 8630 Series RF Oscillator Modules

Specifications in 8620A/8621A System	RF Oscillator Modules				
	8632A ¹³	8633A	3634A	3635A	3636A
FREQUENCY					
Frequency Range:	0.1 - 2 GHz ¹²	1.8 - 4.2 GHz	4 - 8 GHz	8 - 12.4 GHz	12.4 - 18 GHz
Frequency Accuracy (25° C):					
CW Mode ¹	±20 MHz	±20 MHz			
All Other Modes ²	±25 MHz	±25 MHz			
Frequency Stability:					
With Temperature	±750 kHz/° C	±500 kHz/° C			
With 10% Change in Line Voltage	±100 kHz	±100 kHz			
With 10 dB Power Level Change	±1 MHz	±1 MHz			
Residual FM-CW Mode ³	<20 kHz peak	<15 kHz peak			
Linearity: As % of sweep width (for widths ≥1% of calibrated frequency range)⁴	±0.5%	±0.5%			
POWER OUTPUT					
Maximum Levelled Power:⁵	>+10 dBm (10 mW)	>+10 dBm ⁸ (10 mW)	To be announced	To be announced	To be announced
Typical Temperature Coefficient (0 to 55° C)	-0.2 dB/° C	-0.1 dB/° C			
Insertion loss due to internal leveling detector	-	0.5 dB			
Power Variation:					
Internally Levelled	±0.7 dB	±0.6 dB ^{9,10}			
Externally Levelled:					
Crystal Detector ⁶	±0.1 dB	±0.1 dB ¹⁰			
Power Meter ^{6,7}	±0.2 dB	±0.1 dB ¹⁰			
Unlevelled	<±8 dB	<±3 dB			
Spurious Signals (down from fundamental output):					
Harmonic in dB	>-30 dB ¹¹	>-20 dB			
Nonharmonic in dB	>-30 dB ¹¹	>-50 dB			
Residual AM: AM noise in 100 kHz bandwidth (in dB below carrier at maximum rated power)	>-50 dB	>-50 dB			
MODULATION					
External FM (Available on 8621A Rear Panel):					
Frequency Response and Sensitivity:					
FM Mode:	Dc to 2 MHz -20 MHz/V	Dc to 2 MHz -20 MHz/V			
Phase-Lock Mode:	Dc to 2 MHz -1 MHz/V	Dc to 2 MHz -1 MHz/V			
Maximum Deviation:					
DC to 100 Hz rates	±75 MHz	±75 MHz			
To 1 MHz rates	±5 MHz	±5 MHz			
To 2 MHz rates	±2 MHz	±2 MHz			
AM Modulation (On 8620A Rear Panel):					
Internal square wave, blanking on/off ratio at rated power	20 dB min	40 dB min			
External: attenuation with -10V input	15 dB min	20 dB min			
Price:					
Option 001, Internal Leveling	\$1750.00 (Standard)	\$1850.00 Add \$250.00			

¹ Approach desired CW frequency from the low-frequency end of band.

² For sweep durations ≤30 msec. add 2% of sweep width.

³ Bandwidth used in measurement: 8632A, 10 kHz; 8633A, 10 kHz.

⁴ For sweep durations ≤30 msec., first 10% of sweep excluded.

⁵ This specifies the 8621A RF Drawer output power with no options. See 8621A RF drawer specifications for insertion loss of drawer options.

⁶ Excluding coupler and detector variation.

⁷ Works with Hewlett-Packard Models 431B, 431C, and 432A.

⁸ +4.7 dBm when used with 8632A Heterodyne Module. Specified over 2 to 4 GHz; 2 dB less over 1.8 to 4.2 GHz range.

⁹ ±0.8 dB with 8621A, Option 010, 70 dB Attenuator.

¹⁰ Specifications apply 2 dB down from maximum levelled power.

¹¹ Specified at +10 dBm output.

¹² Dial calibrated in START/STOP sweep mode to 100 MHz. Usable in ΔF sweep mode to 50 MHz.

¹³ 8632A is heterodyne unit which requires that 8633A also be installed.

HIGH STABILITY SWEEPER SYSTEMS

Exceptional Frequency Stability, 0.5 - 40 GHz
Models 8320A/8321A/8324A, 8457A



SWEEPERS

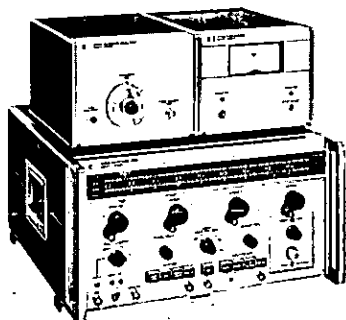

8320A STABILIZED SOURCE

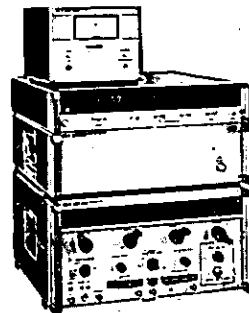

8457A MICROWAVE SYNTHESIZER SIGNAL SOURCE

8320A, 8321A and 8324A Stabilized Microwave Sources

The 8320A, 8321A and 8324A are microwave sources phase-locked to a reference oscillator having good frequency stability. These sources utilize the 8690B and 8620A Sweepers with their plug-in RF units to provide a continuously tunable signal over the 0.5 - 40 GHz range. The 8709A Synchronizer provides a correcting voltage to the Sweeper tuning ramp thus stabilizing it. The 8464A Oscillator is the standard Reference Oscillator supplied, however these sources can be custom-designed to meet most higher frequency stability needs by replacing the 8464A with more stable oscillators. Typical replacements are synthesizers, such as HP 5105A/5110B.

These stable sources are required for sophisticated microwave applications, such as narrow-band receiver and filter tests, parametric amplifier pumps, Doppler system sources, satellite relay communications, radio astronomy, microwave spectroscopy and many others.

Several outstanding features make these sources reliable, easy to use and very flexible. A light on the front panel of the 8709A indicates the Lock or Unlock mode. This light is controlled by an automatic search oscillator which is triggered on as power is applied to the Synchronizer. This oscillator searches continuously for a lock frequency and when the proper frequency is located the signal is locked and the search oscillator is disabled simultaneously. Capture and Lock ranges are wide so that the system can go into phase lock and lock is not interrupted by short term frequency deviations or drifts. The system is broadband so that essentially the stability of the reference oscillator is imparted to the Sweeper. Two more important features are positive identification of lock frequency and system flexibility. Identification of lock frequencies is achieved by elimination of one sideband so that adjacent lock frequencies are separated by the fundamental of the reference oscillator frequency. System flexibility enhances its applications. Higher frequency stability, synchronous and offset phase-lock are variations of its application, which can be configured to meet customers' requirements. Refer to 8320A/8321A/8324A Stabilized Microwave Sources data sheet for details.

Selected Specifications

Stabilized Mode:	CW Only
Frequency Range:	0.5 - 12.4 GHz (8320A) 12.4 - 40 GHz Waveguide (8321A) 0.5 - 4 GHz (8324A)
Typical Frequency:	$\leq 5 \times 10^{-5}$ /hr, $\leq 4 \times 10^{-6}$ /1 min, ≤ 5

Stability:	$x 10^{-7}$ /sec
Typical Residual FM:	$\leq 5 \times 10^{-7}$ rms
Dimensions:	15" high, 19" wide, 18" deep (approximately)
Price:	\$7,500 to \$16,000 depending on band.

8457A Microwave Synthesizer, 8-40 GHz

The 8457A Programmable Microwave Synthesizer System offers today's user the utmost in frequency stability, operating simplicity and systems compatibility. Typical areas of application include automatic test systems, CW/Doppler radar, telecommunications, secure communications, narrow-band filter and receiver testing, anechoic chamber evaluations, radio and radar astronomy, MRR and EPR analytical spectroscopy.

The fully solid-state 8455A Digital Reference Oscillator and 8456A Sweep Control combine with the time-proven 8690B Sweep Oscillator to provide an extremely high degree of frequency stability, ease of operation, flexibility and dependability. Digital frequency readout enables easy verification of programmed output frequency. Unique automatic phase lock circuitry eliminates time consuming manual adjustments and harmonic number calculations required in conventional systems. Precision eight-digit frequency selection is achieved simply from either front panel digital thumbwheel switches or from remote commands. Versatile operating modes include CW, auto sweep, manual sweep and triggered operation. Variable digital sweep rates are provided. Frequency marker spacing is selectable from the front panel.

Full remote and computer interface capability for frequency selection is built-in and no separate programming units are needed. Rapid switching speed further contributes to the ease with which this programmable microwave signal source can be integrated into a wide variety of applications.

Specifications, 8457A

Frequency ranges:	8-12.4 GHz, 12.4-18GHz, 18-26.5 GHz, 26.5-40GHz
Frequency Stability:	Short term: RMS fractional frequency deviation typically less than: 5×10^{-5} per 10 msec, 4×10^{-5} per 100 msec, 7×10^{-10} per second. Long term: better than 5×10^{-9} per 24 hours.
Output power:	same as specifications for HP 8694-7 RF Units
Sweep rates:	0.2, 2, 20, 200 KHz/step, 5, 10, 25, 50 steps/sec
Frequency switching speed:	20 msec
Remote Interface:	F ₁ frequency programmable; T ² L logic levels; 1248 BCD lines per decimal digit.
Complete specifications and options available on request.	
Price:	Model 8457A, \$21,900 to \$28,900 depending on frequency range and options ordered.

SWEEPERS



DIGITAL MARKER

Precise Frequency Measurements while Sweeping
Model 8600A

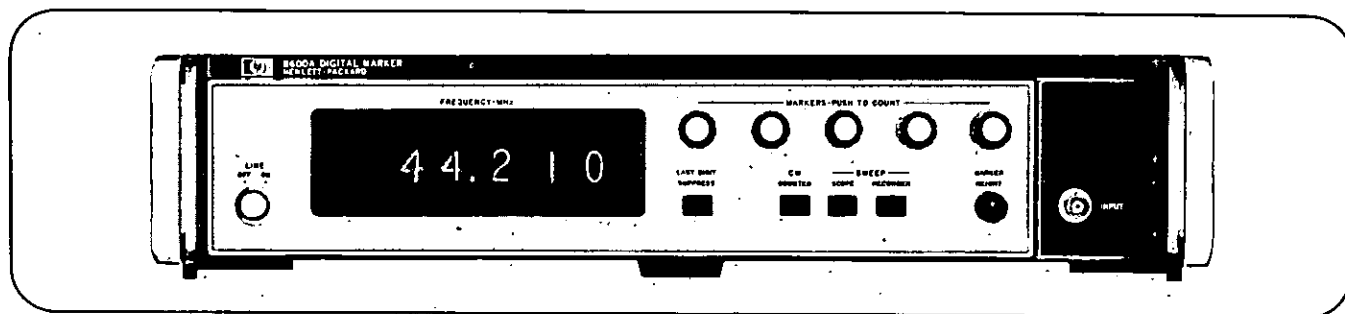

Have you ever wished you could pinpoint key frequencies in a network's response without laborious CW techniques? The new Model 8600A Digital Marker could be the answer. It provides five independent, continuously variable frequency markers over the range 0.1 - 110 MHz when used with the HP 8601A or 8690B/8698B Generator/Sweeper.

The high resolution controls and 6-digit readout permit 0.05% Frequency settability. The frequency of any marker may be read while sweeping, simply by pushing a button within the marker control. The marker selected is brighter than the others and points in the opposite direction, ensuring positive marker identification. The MARKER HEIGHT control varies the height of the marker.

The 8600A must be used with 8601A or 8690B/8698B, since it requires the "sweep inhibit" capability. All sweeper functions are preserved, such as sweep modes and sweep rates. A divide-by-ten frequency output from the sweeper permits frequency markers over the full 0.1 - 110 MHz range of the sweeper with automatic decimal point placement. The LAST DIGIT SUPPRESS may be used to blank the least significant digit. The 8600A may be used with any display having an external horizontal input, such as an oscilloscope, the HP 8407A/8412A Network Analyzer, or a graphical recorder.

Still want more capability? Then push COUNTER mode and use the 8600A as a 100 Hz to 15 MHz counter. Gate time is 10 msec and sensitivity is 100 mV. The internal crystal time base ensures high-accuracy measurements.

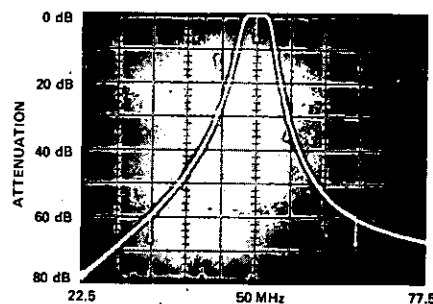

The center frequency, 30 dB, and 60 dB frequencies of this 50 MHz bandpass filter are being identified with the 8600A's variable markers. The marker being counted points up (44.21 MHz), the others point down (34.57, 50.01, 54.87, and 65.39 MHz, from left to right). The height of the markers may be varied with the MARKER HEIGHT control.

Specifications

Marker

When providing markers, the 8600A must be used with the 8601A or 8690B/8698B Generator/Sweeper. Hence, all marker specifications apply only for the 8600A/8601A combination. Markers may be generated on an oscilloscope (SCOPE mode) or recorder (Recorder mode):

Marker Accuracy: Any marker may be placed at a desired frequency $\pm(0.05\%$ of sweep width + 8601A sweeper stability*).

Marker Drift: $\pm 0.1\%/^{\circ}\text{C}$ temperature change.
 $\pm 0.001\%/V$ line voltage change.
 \pm sweeper drift.
 \pm counter stability (refer to COUNTER section).

Typical Marker Drift: When the 8601A is in SYMMETRICAL mode and SWEEP speed < 1 sweep/second is:
 < 5 kHz/10 min. high range.
 < 0.5 kHz/10 min. low range.

Minimum Marker Separation: Approximately 1% of display width.

Counter

Display: 6-digit readout with automatic blanking of leading zeros; least significant digit may be suppressed.

Frequency Measurement:

Range: 0.1 kHz to 15 MHz.

Gate Time: 10 msec (100 Hz resolution).

Input Sensitivity: 100 mV rms to 10 V rms.

Overload: Input should be less than 10 V rms.

Damage Level: 15 V rms, ± 50 V dc.

Impedance: 0.5 M Ω shunted by 30 pF.

Accuracy: ± 1 count \pm time base accuracy.

Time Base:

Frequency: 1 MHz ± 1 Hz

Stability:

Temperature: ± 30 ppm (0° - 50°C); ± 5 ppm (10° - 40°C).

Line Voltage: < 1 ppm for $\pm 10\%$ line voltage variation.

Sample Rate: 5/sec.

Reset: Automatic.

General

Line Voltage: 115-230 V ac $\pm 10\%$; 50-400 Hz; 35 watts.

Weight: Model 8600A: Net, 12 lb 12 oz (5.78 kg). Shipping, 18 lb (8.16 kg).

Dimensions: 3 $\frac{3}{8}$ in. high x 16 $\frac{1}{4}$ in. wide x 13 $\frac{3}{4}$ in. long (99 x 413 x 337 mm).

Price: \$1,100.00.

Option 001: Includes modif. kit for 8690B/8698B; no additional charge.

*Typically < 2 kHz high band, < 0.2 kHz low band.

PROGRAMMABLE COAX ATTENUATORS

Versatile Application to 18 GHz
Models 355E/F; 33300A/B/C/D



MICROWAVE TEST EQUIPMENT

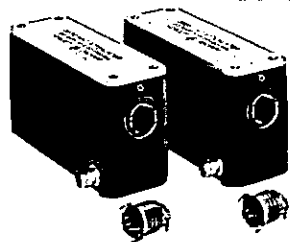

355E/F

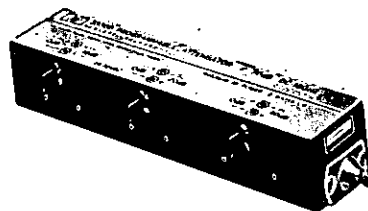

33300A/B/C/D

355E,F Programmable VHF Attenuators

Precision attenuation from DC to 1000 MHz is available with these programmable versions of the reliable manual attenuators - the 355E providing 0-12 dB in 1 dB steps and the 355F providing 0-120 dB in 10 dB steps. Access to highly accurate fixed increments of attenuation is attained by switching power to the proper solenoids through a 7-pin connector. This allows remote control by BCD signals.

Specifications	355E	355F
Attenuation	0-12 dB in 1 dB steps	0-120 dB in 10 dB steps
Frequency Range	DC to 1 GHz	
Overall Accuracy	±0.1 dB @ 1 kHz; ±0.25 dB, DC-500 MHz; ±0.35 dB, DC-1 GHz	±0.3 dB to 120 dB @ 1 kHz; ±1.5 dB to 90 dB, ±3 dB to 120 dB to 1 GHz
Impedance	50Ω nominal	
Max SWR (both ports)	1.2 to 250 MHz; 1.3 to 500 MHz; 1.5 to 1 GHz	
Max Insertion Loss	0.25 dB @ 100 MHz; 0.75 dB to 500 MHz; 1.5 dB to 1 GHz	
Power Dissipation	0.5W average, 350V peak	
Switching Speed	50 ms	
Solenoid Power	+18 to +24V, 1/8 amp.	
Control Connectors	7-pin connector for external control (4 control lines, 1 ground). Mating connector supplied.	
Dimensions (in.)	5 1/16 long, 2 1/16 wide, 2 1/16 high (139 x 97 x 97 mm)	
Weight	Net 1 1/2 lb (0.7 kg); shipping 3 lb (1.4 kg)	
Price	\$275.00	
Option 001	Type N female connectors, add \$25.00	
Option 005	TNC female connectors, add \$10.00	
Option 007	Transistor driver protection, add \$50.00	

33300A,B,C,D Programmable Step Attenuators

These Step Attenuators provide a fast and precise means for electrically controlling the level of signal attenuation in automatic test systems, receivers and other Rf equipment. They provide a total attenuation of 70dB, programmable in 10dB steps over a frequency range of DC to 18 GHz. Magnetic latching solenoids are used to switch individual attenuation elements (tantalum resistive films on sapphire substrates) into and out of contact with a 50 ohm transmission line. Each attenuator is comprised of three attenuation sections (10dB, 20dB and 40dB). By energizing the appropriate solenoids, any combination of these three sections may be put across the 50 ohm transmission line to give the desired level of attenuation. Indicator contacts, which allow the user to determine whether a given section is engaged or not can be supplied. The contacts are closed and remain closed when its respective attenuator section is engaged in series with the transmission line.

Specifications 33300 A/B/C/D

Frequency range: DC - 18 GHz.

Attenuation range: 70dB in 10 dB steps.
Characteristic impedance: 50 ohms.
Insertion loss (max): 0.8 dB DC to 8 GHz
1.2 dB 8 to 12.4 GHz
1.8 dB 12.4 to 18 GHz.

Attenuation accuracy, referenced from 0 dB setting:

Frequency Range	Attenuator Setting						
	10 dB	20	30	40	50	60	70
DC - 12.4 GHz	±.5	±.7	±.9	±1.2	±1.5	±1.8	±2.1
DC - 18 GHz	±.6	±.8	±1.2	±1.6	±2.0	±2.4	±2.8

Power Sensitivity: .001 dB/dB/watt.
Attenuation temperature coefficient: < .0001 dB/dB/°C
Repeatability: ±.02 dB after 1,000,000 cycles (typ).
VSWR:

Frequency Range	Connector-Type		
	SMA	Type N	7 mm
DC - 8 GHz	1.35	1.3	1.25
8 - 12.4 GHz	1.5	1.4	1.35
12.4 - 18 GHz	1.7	1.6	1.5

Input power (max): 2 watts average, 500 watts peak.
Switching speed (max): < 50ms
Life: > 1,000,000 steps, each attenuator section.
Solenoid voltage: 33300 A/C 12 to 15 volts
33300 B/D 24 to 30 volts
Voltage polarity reversal is necessary to switch attenuator section.

Power required to switch one section: 3.3 watts. Continuous operation requires 10 watts dissipation.
Mounting position: any
Weight: 19 ounces (545 grams) with type N connectors.
Dimensions, without connectors: 7" x 1.5" x 1.25" (178 mm x 38 mm x 32 mm).
Prices, 1-9 quantities: 33300A/B \$665.
33300C/D \$690.

Ordering Information 33300

Options are selected by choosing the appropriate model and option numbers:
33300C
selects solenoid voltage and indicator contacts
left port right port
Option 025
connector configuration

	Solenoid Voltage	Indicator Contacts
A	12 - 15V	No
B	12 - 15V	No
C	24 - 30V	Yes
D	24 - 30V	Yes

Option Code	Connector Type
0	Type N Female
1	Type N Male
2	7mm Female
3	7mm Male
5	SMA Female
6	SMA Male



DIGITAL POWER METER

Automatic Zero, High Accuracy
Model 432B

The 432B Digital Power Meter allows convenient, accurate power measurements to be made over the 10 MHz to 40 GHz range. Digital readout and automatic zero simplify measurements over a wide dynamic range from 1 μ W to 10 mW. The 432B is designed to operate with the same temperature compensated, field-proven thermistor mounts as the analog 432A. The internal circuitry is the same as the extremely reliable and accurate 432A Power Meter. The same 8477A Calibrator may be used, allowing use of the digital meter without a large expenditure for new equipment.

Automatic Zeroing: A unique circuit allows you to zero the 432B by merely depressing a front panel switch. The meter can easily be zeroed before each measurement since the time required is so short.

DC Bridge Circuit: Using DC instead of the conventional 10 kHz bias current allows increased accuracy on all measurements. There is no signal emission from the cable or mount to disturb sensitive circuits, and measurements are not affected by capacitive changes caused by movement of the thermistor mount cable. Furthermore, meter zeroing is independent of the impedance connected to the RF terminal of the thermistor mount.

High Accuracy: The 432B offers 0.5% instrumentation accuracy on all power ranges except the 10 μ W range which is 1% over the temperature range, from 20° to 30°C. Even higher accuracy, 0.2% \pm 0.5 μ W, can be attained by measuring the output voltage of the thermistor bridges with a digital voltmeter and computing the corresponding RF power.

Effective Efficiency and Calibration Factor* data are supplied on each thermistor mount; and a front panel control on the 432B is set to the appropriate Calibration Factor or Effective Efficiency to automatically account for losses in the mount.

Flexibility: The 432B provides both analog and digital (BCD) outputs on the rear panel for use with recorders and printers, or for use in power meter leveling of sweepers. Optional thermistor cables up to 200 feet long can be used with the 432B.

Excellent long term temperature stability results from the use of dual self-balancing bridges in a dc feedback amplifier. Thus, long term power level recording is made practical.

Specifications

Instrument Type: Automatic, self-balancing power meter for use with temperature-compensated thermistor mount.

Power Range: 40 dB with full-scale ranges of 10 and 100 μ W, 1 and 10 mW.

Accuracy:

Instrumentation Uncertainty: \pm 0.5% of full scale on 10 and 1 mW and 100 μ W ranges; \pm 1.0% on 10 μ W range.

Zero Uncertainty: \pm 1 count on all ranges.

Calibration Factor Control: 13-position switch normalizes meter reading to account for thermistor mount calibration factor. Range 100% to 88% in 1% steps.

Thermistor Mount: External temperature-compensated thermistor mounts required for operation (HP 478A, 8478B, and 486A series; mount resistance 100 or 200 ohms).

Meter: 3 digits with 1 digit overrange. 20% over range capability on all ranges.

*"Calibration Factor" and "Effective Efficiency" are figures of merit expressing the ratio of the substituted signal measured by the power meter to the microwave power incident on and absorbed by the mount, respectively. The data supplied with each thermistor mount is traceable to the NBS.

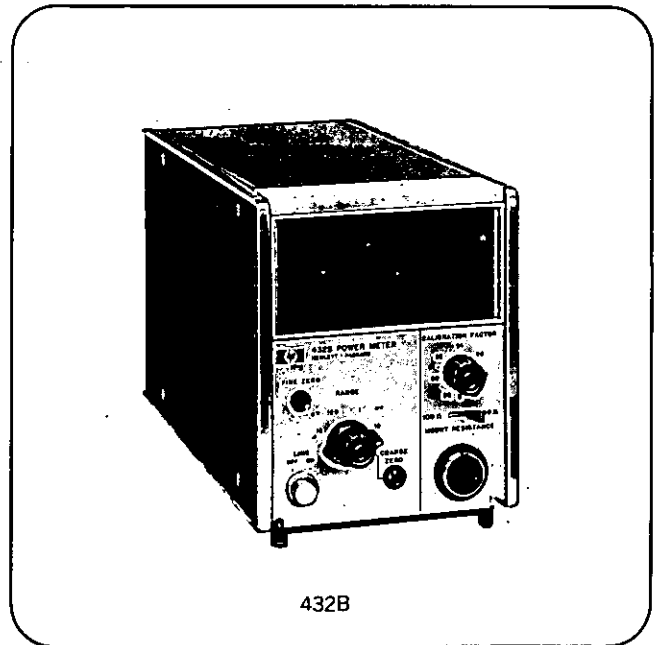

432B

Zero Carryover: Less than 0.5% of full scale when zeroed on most sensitive range.

Noise: Less than 0.25% of full scale peak.

Fine Zero: Automatic, operated by front panel switch.

Recorder output: Proportional to indicated power with 1 volt corresponding to full scale. 1 K Ω output impedance.

BCD Output: 8, 4, 2, 1 code: "1" positive. TTL compatible logic "Print" and "Inhibit" lines available. Operates with HP 5055A Digital Recorder.

RFI: Meets all conditions specified in MIL-I-6181D.

Power: 115 or 230 V ac \pm 10%, 50 to 400 Hz, 8 watts.

Dimensions: 5" wide, 6 3/32" high, 11" deep (130 x 155 x 279 mm).

Accessories Furnished: 5 ft. (1.52 m) cable for Hewlett-Packard temperature-compensated thermistor mounts; 7 1/2 ft. (2.29 m) power cable, NEMA plug.

Accessories Available:

5060-0797 Rack Adapter Frame (holds three instruments the size of the 432B).

11075A, Carrying Case.

Combining Cases:

1051A, 11 1/4" (286 mm) deep.

1052A, 15 3/8" (416 mm) deep.

Weight: Net, 6 lb. 14 oz (3.1 kg). Shipping, 10 lb 5 oz (4.7 kg).

Options:

002: Input connector placed on rear panel in parallel with front, add \$25.

003: Input connector on rear panel only, add \$10.

Note: For cables over 10 feet long, the bridge is matched to specific cable options, so the various cables should not be interchanged.

009: 10 foot (3.05 m) cable only for 100 ohm or 200 ohm mounts, add \$25.

010: 20 foot (6.10 m), add \$50.

011: 50 foot (15.24 m), add \$100.

012: 100 foot (30.48 m), add \$150.

013: 200 foot (60.96 m), add \$250.

Price: Model 432B, \$975.

AUTOMATIC NETWORK ANALYZER

Accuracy to 0.01dB and 0.1°, 0.1 - 110 MHz
Model 8543A



NETWORK ANALYZERS

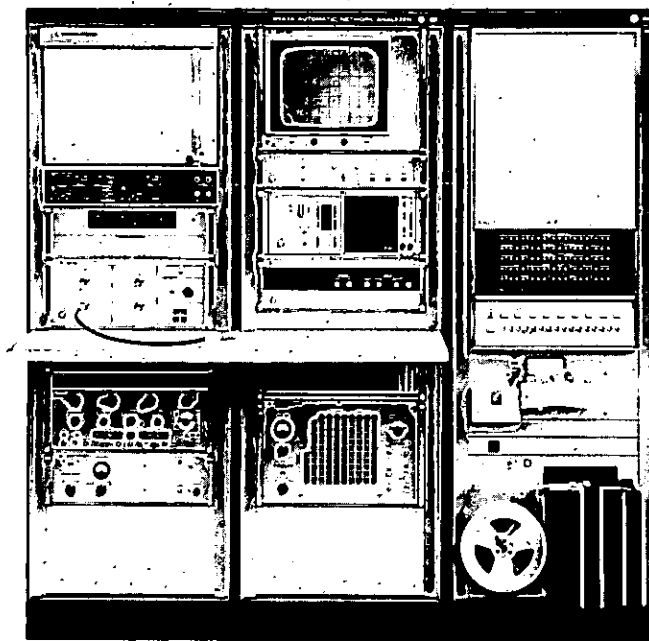

8543A

Introduction

The Hewlett-Packard Model 8543A Automatic Network Analyzer is a complete measurement system covering the important RF range from 0.1 to 110 MHz. Capable of characterizing both active and passive linear devices, the system represents an optimum integration of a small digital computer, a flexible software structure, and broad band RF instrumentation. It achieves unprecedented levels of accuracy, speed, convenience, and flexibility. As a result, the 8543A is capable of making major contributions in such diverse areas as production testing, quality control, RF design, and calibration laboratories. Many RF and IF components and sub-assemblies, such as amplifiers, filters, switches and cable can be accurately and economically characterized.

Description

The 8543A provides all the functions necessary, for the measurement of both driving-point and transfer parameters on the device under test. Its major components include a signal source to provide excitation, a network analyzer to measure the appropriate response, and a small computer for control and data manipulation.

In operation, the 8543A is first calibrated against precise physical standards. The results of these measurements are used to determine the system's own frequency dependent characteristics. During the measurement of an unknown device, the process is reversed and systematic errors are removed by performing computations on the raw data. In this manner, the 8543A achieves a degree of accuracy and repeatability which far exceeds that which is possible utilizing manual techniques.

Operation of the system is extremely simple. All communication is accomplished via teletype, in English language, with the controlling program requesting information and issuing commands. Measurements are made at rates up to 40 per second. Any desired network characteristic can be calculated and outputted in the form of hard copy, CRT display, X-Y graphs, or punched tape. In a high-speed production testing application, the system can compare a test device against predetermined specifications and give a pass/fail indication. In addition, the system is capable of comparing two devices, such as a standard and an unknown, to a high degree of accuracy. This feature is also useful for selecting matched components rapidly and economically.

Software

The 8543A is supplied with a series of general purpose application programs in the form of absolute tapes. These programs are thoroughly documented and ready to execute. They accommodate a large number of measurement needs.

In some user applications, effective utilization of the system will require that modified or special measurement programs be constructed. To this end, the 8543A software structure has been designed in a highly modular form. Included are FORTRAN sub-routines which perform the major system functions such as calibration, corrected measurements, complex mathematics, data plotting, and instrument control. These sub-routines are documented and supplied in the form of source or library tapes. In this way, the 8543A can quickly be adapted to a large number of special applications with a minimum of programming effort.

For complete system information or a quotation on a system designed to meet your needs, call your local Hewlett-Packard Field Engineer.

NETWORK ANALYZERS



MICROWAVE SYSTEMS

Swept Measurements 0.11 - 12.4 GHz
Model 8410S, Option 110, 210, 310 Systems

Choice of three new options.

These three options of the 8410S Network Analyzer System include the 8412A Phase Magnitude Display. This unit replaces the 8413A Phase Gain Indicator meter display that is part of the 8410S Options 100, 200, and 300. A complete description of the capabilities and benefits of the 8410S Sys-

tem as well as system and individual instrument specifications can be found on pages 379-384 of the 1970 Hewlett-Packard Electronic Instrument Catalog or in the 8410S Network Analyzer data sheet.

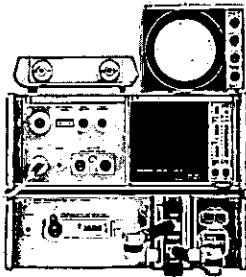

8410A Network Analyzer
8411A Harmonic Frequency Converter
8412A Phase Magnitude Display
8414A Polar Display
8745A SParameter Test Set
11599A Quick Connect Adapter
11604A Universal Extension
11609A Cable Kit
11650A Accessory Kit
Frequency range: 0.11 - 2.0 GHz.

The 8410S Option 110 System

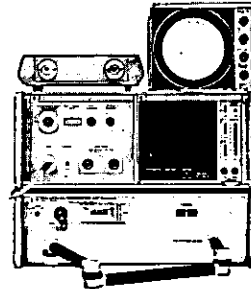

8410A Network Analyzer
8411A Harmonic Frequency Converter
8412A Phase Magnitude Display
8414A Polar Display
8743A Reflection - Transmission Test Unit
11605A Flexible Arm
11609A Cable Kit
11650A Accessory Kit
Frequency range: 2.0 to 12.4 GHz.

The 8410S Option 210 System

Transmission-reflection selection: manual by front panel lighted pushbuttons indicating the S-parameter being measured; remote by contact closure or saturated transistors through 36-pin connector contacts.

RF input: 20 dB range between -21 dBm and +7 dBm. 20 dB variation causes less than 0.5 dB and 4° change in amplitude and phase reading.

Directivity: > 36 dB (typically > 39 dB), 0.11 - 1.0 GHz.
> 32 dB (typically > 36 dB), 1.0 - 2.0 GHz.

Accuracy: Completely specified in the data sheet.

Price: \$12,520.00

Transmission-reflection selection: manual by front panel lighted pushbuttons; remote by contact closure or saturated transistors through 36-pin connector contacts.

RF input: 20 dB range between -14 dBm and +14 dBm. 20 dB variation causes less than 1.5 dB and 4° change in amplitude and phase readings.

Directivity: ≥ 30 dB, 2.0 - 12.4 GHz.

Accuracy: Completely specified in the data sheet.

Price: \$11,680.00

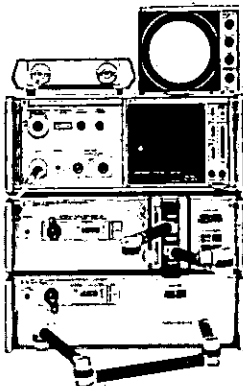

8410A Network Analyzer
8411A Harmonic Frequency Converter
8412A Phase Magnitude Display
8414A Polar Display
8743A Reflection-Transmission Test Unit
8745A SParameter Test Set
11599A Quick Connect Adapter
11604A Universal Extension
11605A Flexible Arm
11609A Cable Kit
11650A Accessory Kit
Frequency Range: 0.11 - 12.4 GHz

The 8410S Option 310 System.

Specifications for Model 8410S Option 310 are a combination of Models 8410S Option 110 and 8410S Option 210. All specifications for those models pertain directly to the 8410S Option 310 at the frequencies of interest.

Price: \$15,770.00.

MICROWAVE SYSTEMS

Semiconductor S-Parameter Measurements

Model 8410S Options 400/401, 500/501, 8746B, 11608A, 11607A



NETWORK ANALYZERS

S-Parameter Measurement Systems.

The individual instruments in these 8410S Network Analyzer System configurations permit the user to make semiconductor S-parameter measurements over the frequency range 0.11 to 2.0 GHz and 0.5 to 12.4 GHz. A complete description of the capability, flexibility and benefits of these systems as well as system and individual instrument specifications can be found in the respective data sheets.

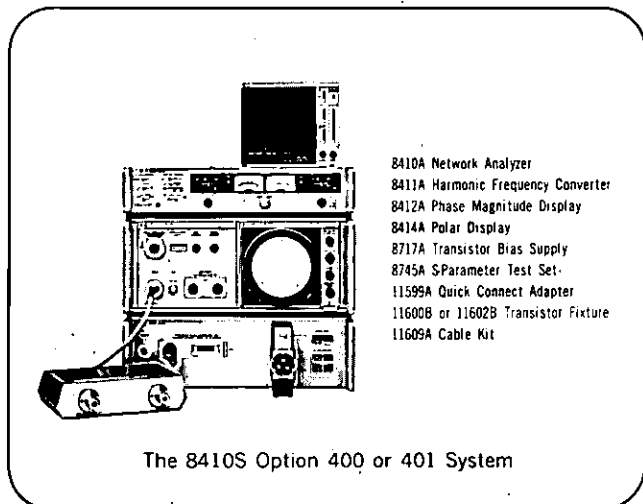

The 8410S Option 400 or 401 System

Function: These systems provide the capability for characterizing semiconductors in a variety of package formats.

Option 400: Accepts devices with TO-18/TO-72 or similar packages. Uses the 11600B Transistor Fixture.

Option 401: Accepts devices with TO-5/TO-12 or similar packages. Uses the 11602B Transistor Fixture.

S-parameter selection: manual by front panel lighted push-buttons; remote by contact closure or saturated transistors through 36-pin connector contacts.

Frequency range: 0.11 to 2.0 GHz.

Price: \$13,005.00.

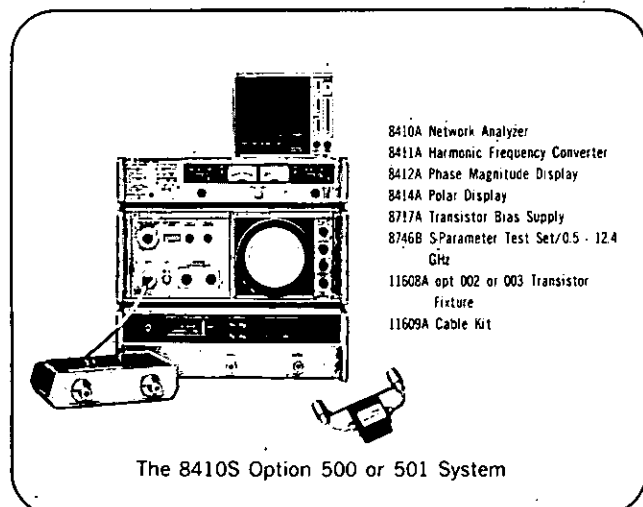

The 8410S Option 500 or 501 System

Function: These systems provide the capability for characterizing stripline transistors.

Option 500: Holds TI-line packages. Uses the 11608A option 002 Stripline Transistor Fixture.

Option 501: Holds K-disc packages. Uses the 11608A option 003 Stripline Transistor Fixture.

Frequency range: 0.5 to 12.4 GHz.

Price: \$14,655.00

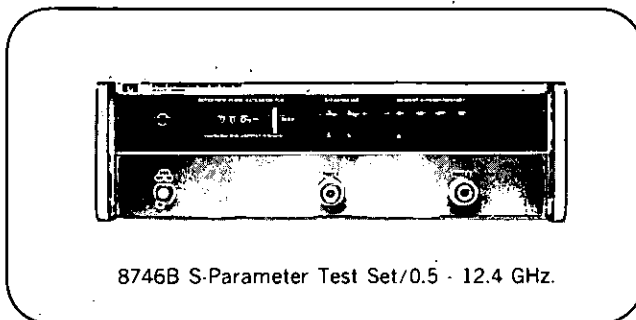

8746B S-Parameter Test Set/0.5 - 12.4 GHz.

Function: Wide band RF power divider and reflectometer with calibrated line stretcher and a selectable 0 - 70 dB incident signal attenuator. Provides internal bias tees for completely characterizing two port active devices.

S-Parameter selection: All four S-parameters selected manually by front panel lighted pushbuttons; remotely by contact closure or saturated transistors through 36-pin connector contacts.

Frequency range: 0.5 to 12.4 GHz.

Directivity: > 30 dB, 0.5 - 4 GHz;

> 26 dB, 4 - 12.4 GHz

Price: \$5,000.00

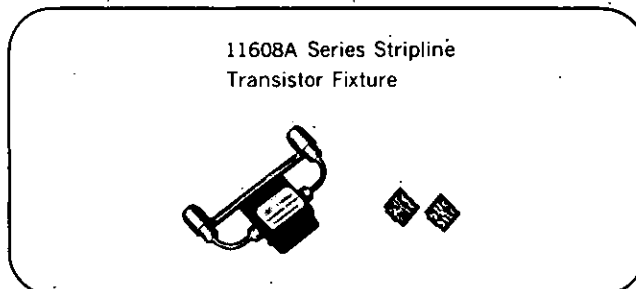

11608A Series Stripline Transistor Fixture

Function: Holds stripline devices for S-Parameter measurements in a 50-ohm microstrip.

Option 001 includes blank grounding and clamping inserts for custom machining. Other packages and stripline material available on request.

Option 002 accepts TI-line package. (0.250" dia.)

Option 003 accepts K-disc package. (0.205" dia.)

Frequency range: dc to 12.4 GHz

Stripline: Width: 0.082 inch

Material: PPO - 0.031 inch thick.

Calibration units: Thru and short sections provided with options 002 and 003.

Price: 11608A opt 001, \$375.00

11608A opt 002, \$400.00

11608A opt 003, \$400.00

11607A Small Signal Adapter.

Function: Used with the Hewlett-Packard Model 8745A S-Parameter Test Set, it permits measurements with Model 8410A Network Analyzer with incident signals levels to the test device in the -20 to -40 dBm range.

Frequency range: 0.11 to 2.0 GHz.

Price: \$600.00

NETWORK ANALYZERS



NETWORK ANALYZER ACCESSORIES

Accurate Measurements of Magnitude & Phase
8407A Accessories: 11655A, 1121A, 8721A

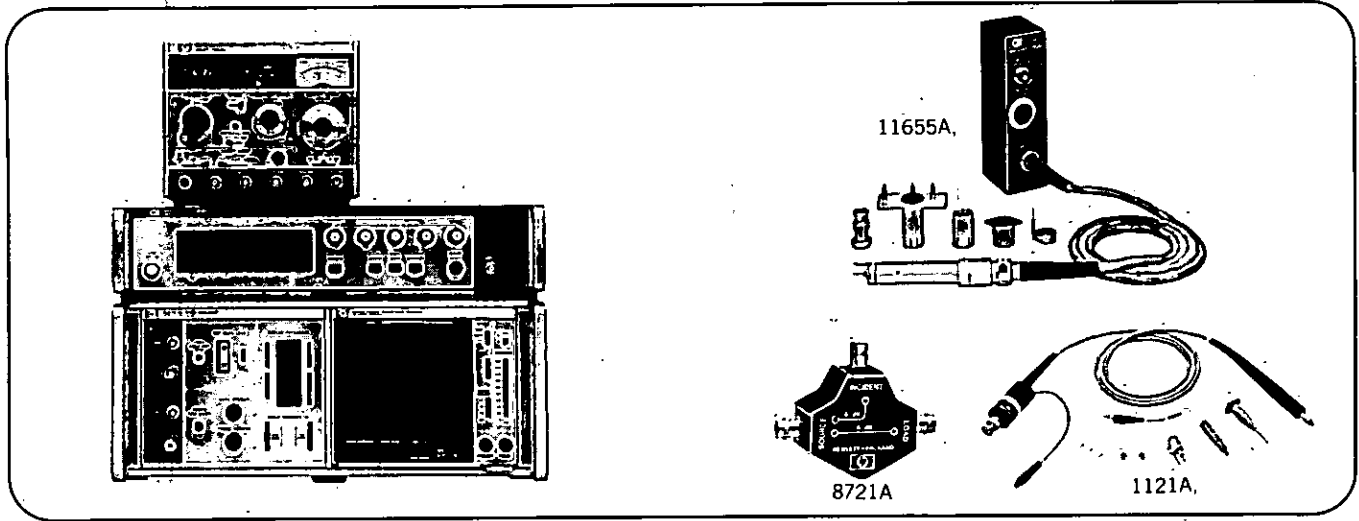

Magnitude And Phase From .1 - 110 MHz

The 8407A Network Analyzer swept system measures the transmission, reflection, and impedance properties of RF networks from 0.1 - 110 MHz. You can determine the magnitude and phase of important parameters such as gain or attenuation, return loss, and complex impedance. The phase measuring capability also permits you to determine the phase linearity, electrical length, and group delay of phase-sensitive networks.

The basic 50-ohm system for measuring swept transmission and impedance is described beginning on Page 367 of the 1970 Hewlett-Packard catalog. Various new accessories and capabilities are described below.

75-Ohm Network Analysis System

Here is a complete 75-ohm measurement system (0.1 - 110 MHz) with typical performance equivalent to the 50-ohm system:

8601A Generator/Sweeper, option 008	\$2280
8600A Digital Marker	\$1100
8407A Network Analyzer, option 008	\$3150
8412A Phase-Magnitude Display	\$1575
11652A Reflection/Transmission Kit, option 008	\$425
Total \$8530	

1121A 500 MHz AC Probe

The 1121A 500 MHz ac Probe permits transmission measurements of high impedance circuits or difficult-to-reach test points. Its 100 k ohm, 3 pf input impedance ensures accurate measurements without adverse loading effects. In addition, any two probes may be matched for ± 0.5 dB amplitude tracking and $\pm 2^\circ$ phase tracking, permitting dual-probe measurements of individual amplifier stages, filter sections, etc.

Price: Model 1121A, \$350.

8721A Directional Bridge

The 8721A Directional Bridge (functionally similar to a directional coupler) is an extremely useful measurement device for the 100 kHz - 110 MHz range. Characteristic impedance is either 50 ohms (8721A) or 75 ohms (8721A option 008).

It is easy to use for both reflection and transmission measurements. As a reflectometer, it has 40 dB directivity and

load port VSWR < 1.07. In the transmission mode, it serves as a power splitter (6 dB loss in each arm). Overall frequency response in either mode is < 0.8 dB.

Price: Model 8721A, \$150; Model 8721A opt 008, \$185.

11655A Impedance Probe

The most dramatic new capability of the 8407A is its ability to measure complex impedance on a swept basis over an 80 dB dynamic range: $< 1 \Omega$ to $> 10 \text{ K ohms}$. This is made possible by the new 11655A Impedance Probe, which utilizes the ratio measurement made by the 8407A.

The technique is to obtain a signal proportional to voltage in the 8407A's TEST channel and a signal proportional to current in the REFERENCE channel. The resulting ratio $V/I = Z$ is displayed in two forms: as Z, θ versus frequency (Figure 1) or as $R \pm jX$ as a function of frequency (Figure 2).

The 11655A Complex Impedance Probe interconnects directly between the sweeper and the network analyzer—no other cabling is necessary. The probe itself has a variety of fixtures and adapters—BNC, terminal post, probe—to ensure easy testing of networks, devices or components, and in-circuit test points. In addition, the 4-terminal measurement technique eliminates most of the stray impedance effect of the probe, permitting the wide measurement range.

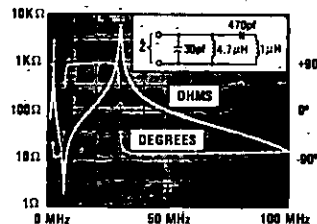

Fig. 1 Wide impedance excursions are displayed in log form, along with the phase angle. Here, a series-parallel resonant circuit is characterized for resonances and anti-resonances up to 100 MHz.

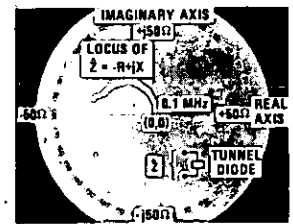

Fig. 2 The complex impedance of active and passive networks may be characterized. Here is the negative resistance characteristic of a tunnel diode from .1 to 10 MHz. Values of $-R + jX$ are easily determined.

Specifications

Frequency Range: 0.5 - 110 MHz.

Impedance Range: 1Ω to $10 \text{ k}\Omega$; 0 to ± 180 degrees.

Price: Model 11655A, \$750.

FREQUENCY DOMAIN MEASUREMENT



SIGNAL ANALYZERS

Hewlett-Packard spectrum analyzers are finding new and different applications. They have evolved into general-purpose instruments, opening up the frequency domain just as the oscilloscope opened up the time domain. Anyone interested in measuring signal amplitude versus frequency will find spectrum analyzer applications limited only by his imagination.

Qualitative Spectrum Analysis

Basically a spectrum analyzer is a swept receiver that continuously measures the individual frequency components of a signal and displays the resulting frequency spectra on a CRT. Although early spectrum analyzers did give a broadband view of the frequency domain, they were difficult to operate and could not be relied upon for accurate measurements of voltage, power, or frequency. When engineers required quantitative information, they employed power meters, RF voltmeters, frequency meters, and counters to measure a single parameter or special purpose distortion meters, wave analyzers, and EMI meters to measure both amplitude and frequency in a point by point fashion.

Quantitative Spectrum Analysis

Several years ago Hewlett-Packard developed a spectrum analyzer that combined the qualitative spectrum viewing characteristics of earlier spectrum analyzers with the quantitative measurement capabilities of power meters, voltmeters, etc.

With this analyzer, both signal strength, in millivolts or milliwatts (dBm), and signal frequency could be read directly off a fully calibrated CRT display. Absolute calibration, coupled with improvements in dynamic range, sensitivity, signal resolution, frequency scan and flatness, made the spectrum

analyzer ideally suited for a variety of new measurement applications.

Plug-In Spectrum Analyzer System

The instrument was actually made up of three sections: an RF section, IF section, and Display section in an oscilloscope type plug-in configuration. In this system the RF section determines the frequency range and most of the key specifications. It is essentially a swept receiver that mixes RF signals at the input down to a fixed IF frequency. The IF section contains IF filters, linear and log amplifiers, and post detection video filters which determine signal resolution and display characteristics. The display section provides the CRT and serves as a mainframe for the RF and IF sections.

Initially, the system consisted of an 8553L RF section, which covered the frequency spectrum from 1 kHz to 110 MHz, an 8552A IF section, and a 140S Fixed Persistence Display, 141S Variable Persistence Display or 143S Large Screen Display Section.

More recently a second RF section was added to extend quantitative spectrum analysis up to 1250 MHz. This RF section, the 8554L, is completely compatible with the existing IF and display sections. The 8554L, 8553B (which replaces the 8553L), 8552A, 140S, 141S, and 143S are all fully described in the 1970 Electronics edition of the Hewlett-Packard catalog.

Complete Coverage from 1kHz to 40GHz

Subsequent to the publication of the 1970 Catalog, several new instruments have been developed which expand the measurement capability of the plug-in spectrum analyzer system.

Perhaps the most significant contribution is provided by a new RF section that brings quantitative spectrum analy-

sis to the microwave frequency range. This section, the 8555A, employs harmonic mixing to cover a frequency range from 10MHz to 18GHz with an internal mixer. Coverage from 12.4 to 40GHz is available with external waveguide mixers. Providing absolute calibration in a harmonic mixing analyzer is particularly difficult, because conversion loss varies between mixing modes. In the 8555A, compensating amplifiers eliminate these gain variations making it possible to directly compare two signals that fall in different bands. To further improve amplitude accuracy, the mixer has been carefully designed to minimize parasitic capacitance resulting in flat response, even on high harmonic mixing modes. Figure 1 illustrates the 8555A's frequency response over six different bands. For additional measurement capability, signal resolving capability has been improved an order of magnitude over other microwave spectrum analyzers. Receiver stability is the key to achieving usable resolution. In the 8555A, a crystal oscillator and an AFC loop are employed to stabilize the first local oscillator for narrow band operation. Tuning is accomplished by varying the frequency error reference voltage. In this way, stability near that of a crystal oscillator is obtained.

Tracking Signal Sources

To make frequency response measurements of a device with a spectrum analyzer requires an external signal source. Traditionally, a signal generator or sweeper is tuned through the frequency range of interest, and the output of the test device is displayed on the spectrum analyzer.

The 8443A Tracking Generator/Counter and the 8443B Tracking Generator are new companion units for the 8553B 1kHz to 110MHz Spectrum Analyzer. The use of a tracking source al-

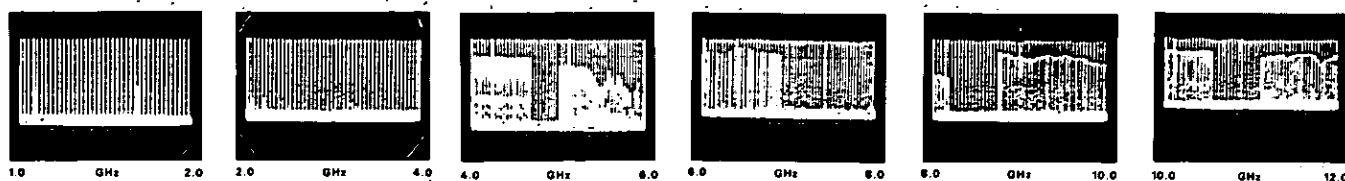

Figure 1. The flat frequency response of the 8555A Microwave Spectrum Analyzer is demonstrated by the series of photos above. Levelled sweep oscillators were used as signal sources over the range from 1 to 12 GHz. The input level was -30 dBm in all bands, and the LOG REF level (top graticule line) is -10 dBm for each photo.

lows measurements over the full amplitude range from +10dBm to -130dBm since spurious responses are not displayed. These tracking generators also inherit the high stability of the spectrum analyzer (typically < 1Hz residual FM with the 8552B IF Section) allowing measurement on extremely high-Q devices.

The 8443A Tracking Generator/Counter offers the additional benefit of a 10Hz resolution frequency counter. A moveable marker is generated on the spectrum analyzer display, and its frequency is displayed on the direct reading counter. With this marker, the frequency of any signal appearing on the spectrum analyzer can be precisely measured.

High Resolution Spectrum Analysis

The new 8552B IF Section offers improved resolution for all the plug-in spectrum analyzers.

Higher resolution is obtained in part through the use of IF filters with better skirt selectivity. The skirt selectivity determines the resolution for signals which differ in amplitude. This is important in the measurement of such parameters as modulation index where the sidebands will be close to the carrier and usually different in amplitude.

In addition to the improved skirt selectivity, the 8552B has IF bandwidths of 30 Hz and 10 Hz which are selectable with the 8553B RF section. These narrower bandwidths are made possible through the use of a unique circuit to improve the stability of the spectrum analyzer to less than 1 Hz residual FM.

Amplitude resolution is improved as well with the addition of a 2dB per division log scale to complement the 10dB per division scale.

Variable Persistence Display

The new 141T Variable Persistence Display Section allows the use of slow scanning rates required for high resolution analysis. Even at the slowest scans, a bright, flicker-free trace is seen instead of a slowly moving CRT dot. The 141T offers all the features of the 141S it replaces. In addition, a larger, rectangular CRT is used and pushbuttons operate many of the major functions. Also new is the 140T Normal Persistence Display Section. It, too, has the rectangular CRT with increased graticule area.

Complete Spectrum Analyzer System

The different components which comprise a complete spectrum analyzer are all fully compatible. A complete analyzer consists of an RF section, an IF section, and a display section.

The available units are:

RF Sections:

model 8553B	1kHz - 110MHz
model 8554L	500kHz - 1250MHz
model 8555A	10MHz - 40GHz

IF Sections:

model 8552A	Standard IF
model 8552B	High Resolution IF

Display Sections:

model 140T	Normal Persistence
model 141T	Variable Persistence
model 143S	Large Screen

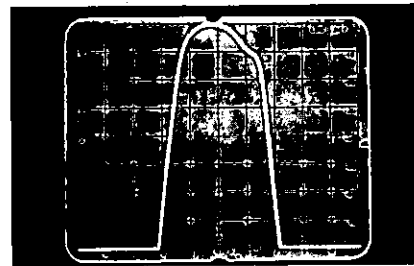

The same crystal filter is measured with the vertical scale now 2 dB per division. Passband variations can be examined in detail, and the frequencies of the 3 dB down points can be accurately measured. The spectrum analyzer scan is 500 Hz per division centered at 20 MHz.

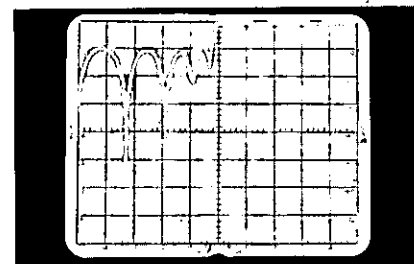

Swept return loss measurements can also be made with a tracking signal source and a suitable directional device. Here a return loss measurement was made on a 50 MHz low pass filter. The spectrum analyzer gain was adjusted so that the top graticule line represents 0 dB return loss or total reflection. The spectrum analyzer scan is 10 MHz per division centered at 50 MHz. As we would expect, there is almost total reflection above 50 MHz. In the passband, however, return loss is greater than 10 dB ($\rho < 0.32$, SWR < 1.92).

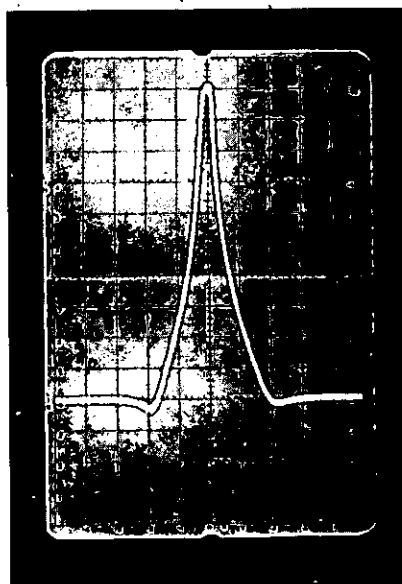

The use of a tracking signal source for making swept frequency response measurements is demonstrated in the photo above. The response of a crystal filter was measured over a range greater than 100 dB by superimposing two CRT photos. The frequency marker was centered on the response, and the center frequency of the filter was read from the counter on the 8443A Tracking Generator/Counter as 20.00020 MHz. The spectrum analyzer scan is 5 kHz per division centered at 20 MHz. The tracking generator output was set to +10 dBm, and the LOG REF level (top graticule line) was also +10 dBm. Therefore, the insertion loss is 10 dB.

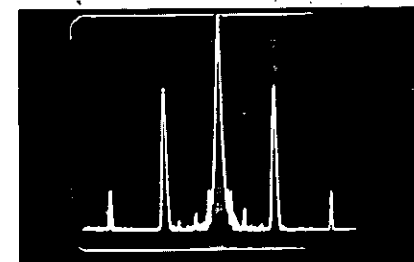

A stable signal generator was amplitude modulated with a 400 Hz tone. The first order sidebands are 26 dB down indicating 10% AM. Harmonic modulation distortion of 1% (second order sidebands 40 dB below first order sidebands) can easily be measured. The high resolution also allows us to see line-related sidebands on the carrier more than 60 dB down. The spectrum analyzer scan is 200 Hz per division centered at 30 MHz. The 10 Hz IF bandwidth was used for highest resolution.

TRANS. NOISE ANALYZER

Measures i_n , e_n , NF for bipolar and FET's
Model 4470B



SIGNAL ANALYZERS

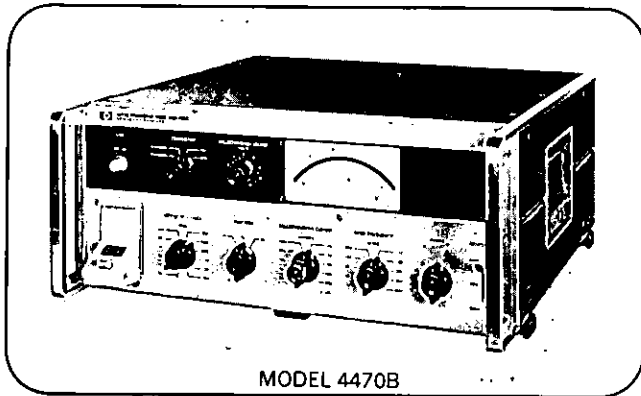

MODEL 4470B

The HP 4470B Transistor Noise Analyzer evaluates accurately transistor noise voltages (e_n), noise currents (i_n) as well as direct measurement of noise figure (NF).

This Noise Analyzer performs "spot" frequency measurements at 9 frequencies between 10 Hz and 100 kHz. Noise is carried by the spot frequency "pilot" signal in sidebands at 10 Hz above and below the pilot frequency. Total noise measured, equivalent to transistor noise at the spot frequency, is the average of the noise in the two sidebands.

Tentative Specifications

Noise parameters measured

Voltage noise: (e_n) referred to the input of the transistor under test, in both bipolar and FET's.

Current noise: (i_n) referred to the input of transistor under test, in bipolar transistors.

Spot noise figure: (NF) for both bipolar and FET.

Available ranges

Voltage noise: 3 nV, 10 nV, 30 nV, 100 nV, 300 nV, 1 μ V and 3 μ V F.S. at 1 Hz bandwidth. Two meter scales of 0 to 3, 0 to 10 and X1, X10, X100 multipliers. Ranges as a function of spot frequency are: all ranges at 10 and 30 Hz, 3 nV to 1 μ V at 100 and 300 Hz; 3 nV to 300 nV at 1 k and 3 kHz; 3 nV to 100 nV at 10 k and 30 kHz; 3 nV to 30 nV at 100 kHz.

Current noise: refer to chart for applicable noise current measurement limits (referred to 1 Hz bandwidth). Max. freq. for each current noise range is shown in chart.

COLLECTOR/ DRAIN CURRENT SETTING	NOISE CURRENT RANGES AS FUNCTION OF DRAIN CURRENT USED:											
	100 μ A	300 μ A	1000 μ A	3 mA	10 mA	30 mA	100 μ A	300 μ A	1000 μ A	3 mA	10 mA	30 mA
1, 3 μ A												
10, 30 μ A												
100, 300 μ A												
1, 3 mA												
10, 30 mA												

(NOTE: 1A = 1 amp = 1000 mA, 1mA = 10⁻³ A)

Spot noise figure: (NF) 0-40 dB; meter scaled from -5 dB to +10 dB.
Ranges are: -5 dB to +10 dB; +5 dB to +20 dB;
+15 dB to +30 dB; +25 dB to +40 dB.

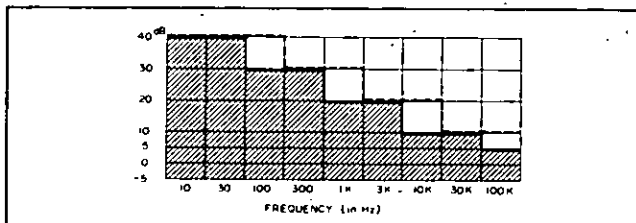

Noise level below the heavy line is measurable for the bipolar transistor. Noise level below the broken line is measurable for FET.

Spot frequencies: 10 Hz, 30 Hz, 100 Hz, 300 Hz, 1 kHz, 3 kHz, 10 kHz, 30 kHz, and 100 kHz.

Noise bandwidth: 4 Hz. Noise is measured in pilot signal sidebands centered at ± 10 Hz from spot frequency. Sidebands are 4 Hz wide. Pilot signal equals spot frequency except at 10 and 30 Hz where 100 Hz carrier is used.

Collector/Drain power supplies: currents of 1, 3, 10, 30, 100 μ A, 0.3, 1, 3, 10 and 30 mA are provided with continuous adjustment between values. Voltages of 0 to 15 V dc, continuously variable. Both supplies are independent of each other. Current supply seeks desired setting.

Transistor types: bipolar NPN and PNP, P-channel or N-channel FET noise may be analyzed.

β -Range: Bipolar Transistors with h_{FE} from 10 to 1000 are measurable.

gm-Range: See chart:

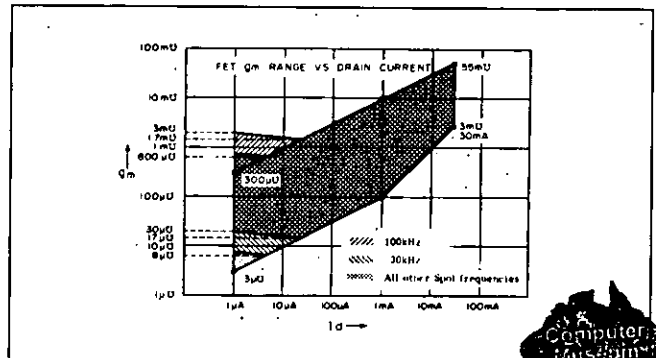

Source resistance

Values provided for use when measuring Noise Figure are 50 Ω , 100 Ω , 500 Ω , 1 k Ω , 5 k Ω , 10 k Ω , 50 k Ω , 100 k Ω , 500 k Ω , 1 M Ω , 5 M Ω and 10 M Ω .

Meter response: Time for meter fluctuation to be averaged is determined by the Response switch setting and will vary from a fast response of 4 s to a slow response of > 24 s.

Transistor bias/supply outputs: Collector/Drain current, Collector/Drain Voltage, Base/Gate Voltage.

Recorder output: proportional to meter deflection. 0 to 1 V dc, 1 k Ω output resistance.

Accuracies

Collector/Drain voltage: $\pm 3\%$ at monitor jack; $\pm 10\%$ at front panel; $\pm 3\%$ at calibrated front panel settings except 1 μ A where accuracy is $\pm 5\%$.

Collector/Drain current: $\pm 3\%$ at monitor jack; $\pm 3\%$ at calibrated front panel settings.

Spot freq: $\pm 3\%$. Noise bandwidth: $\pm 3\%$. Total accuracy: $< \pm 1$ dB.

(NOTE: accuracy for NF measurements on bipolar devices is unspecified if the product of base current and source resistance exceeds β volts and for e_n and NF if V_{GS} exceeds ± 12 V on FET's).

Transistor socket configurations: 6 sockets provided.

Power required: 115/230 V ac, $\pm 10\%$, 50 or 60 Hz, 60 W.

Dimensions: 16 3/4" wide, 6 31/32" high, 18 3/8" deep (425 x 177 x 467 mm).

Weight: 32 lb, (14.5 kg).

Accessories provided: power cord, Transistor socket kit (includes six sockets).

Accessories available: transistor socket kit including six modular sockets, HP No. 16009A, \$75.

Modular sockets, \$10. each.

Price: HP 4470B, \$3950.





TRACKING GENERATOR/COUNTER

New Measurement Capability for Spectrum Analyzers
Models 8443A, 8443B

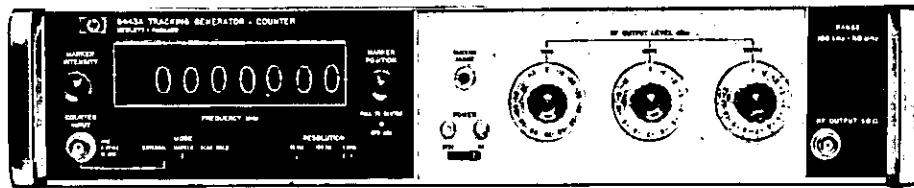

8443A

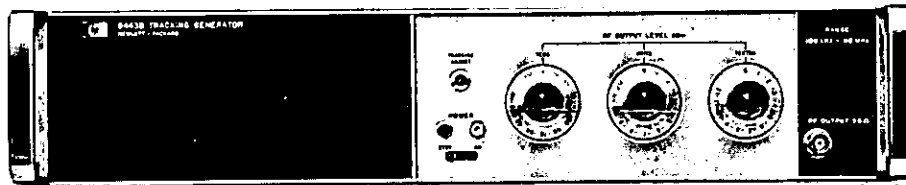

8443B

Features:

- Swept Transmission/Reflection Measurements**
- 120 dB Dynamic Range/Return loss up to 40 dB
 - 0.1 dB Amplitude Resolution
 - 10 Hz Frequency Resolution
 - Sweep Widths from 200 Hz to 100 MHz
- Precision Frequency Measurements**
- 10 Hz Resolution
 - 25 nV (-140 dBm) sensitivity
 - 20 Hz Selectivity
 - Movable Marker

Description

The 8443B Tracking Generator and 8443A Tracking Generator/Counter add a totally new dimension to the spectrum analyzer making it an extremely versatile, precision frequency domain measurement system.

8443B Tracking Generator

The 8443B is a swept signal source whose output frequency tracks the input frequency of the spectrum analyzer. With a swept source, the analyzer can make swept frequency response and return loss measurements on filters, amplifiers, antennas, etc. The combination of a tracking source and selective detector eliminates harmonic and spurious responses from the display allowing a measurement range of more than 120 dB. An additional result of the analyzer's selectivity is the ability to make swept frequency response measurements in the presence of high level signals or noise.

Because the tracking generator's output is derived by mixing a crystal oscillator with the spectrum analyzer's local oscillators, it shares the analyzer's excellent stability and flatness. These qualities allow quick and accurate characterization of high Q devices. In addition to exceptional stability and flatness, absolutely calibrated, continuously variable output make the 8443B useful as a precision signal generator.

8443A Tracking Generator/Counter

In the 8443A, frequency counter and variable marker capabilities are combined with the sweeper/signal generator capability of the 8443B. The Tracking Generator/Counter provides a marker which can be placed anywhere on the analyzer's display and measures the frequency of that point to seven digits. Making use of the spectrum analyzer's sensitivity and selectivity, the counter can measure the frequency of extremely low level signals even in close proximity to much larger signals. With the 8443A Tracking Generator/Counter, precision frequency measurement with 10 Hz resolution is brought to spectrum analysis and spectrum surveillance as well as swept frequency response measurements.

The frequency counter and variable marker section can be added to the 8443B Tracking Generator with an easy to install modification kit, the 11663A.

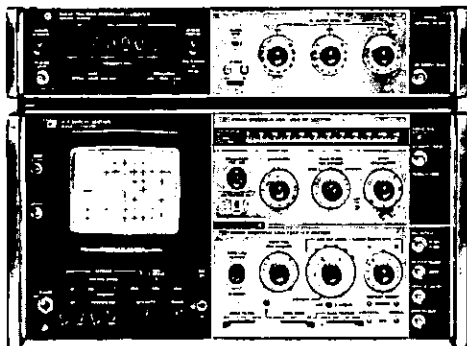

8443A With
8553B/8552A/141T

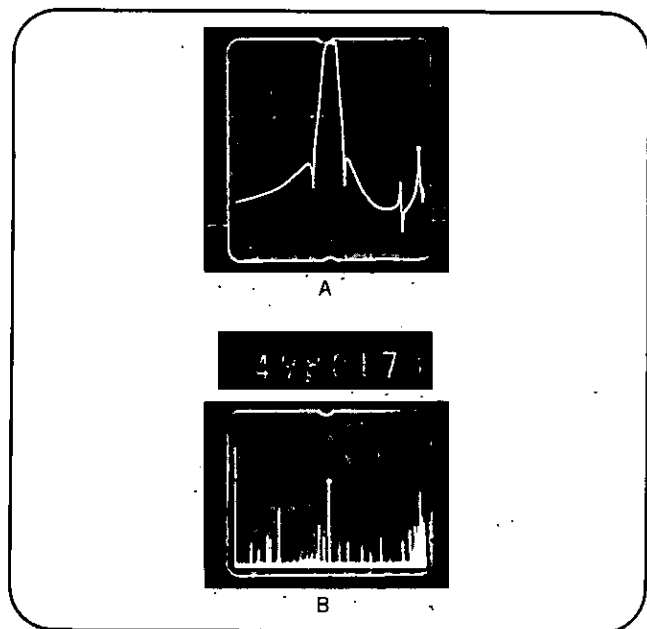

Figure 1. A frequency response measurement, shown in Photo A, reveals detail in the stop band 100 dB down. This is a 20 MHz crystal filter with a 60 dB bandwidth of 7.48 kHz (measured with the 8443A counter; the scan width is 5 kHz/division). The filter was to have greater than 60 dB rejection, however, a spurious mode at 20.0232 MHz is only 55 dB down. To show the entire response of the filter at one time, two CRT photographs were superimposed. Using this technique, frequency response could be displayed over a range greater than 120 dB. Photo B illustrates an application of precision frequency measurement. The display is the radiated spectrum from 0 to 100 MHz at Palo Alto, California. The marker was centered on the strong signal at about 50 MHz, and its frequency was accurately measured as 49.80170 MHz. The carriers for TV channels 2, 4, and 5 appear on the CRT as do the local FM stations. The precise frequency of any of these signals could be measured just as easily.

8443 Tracking Generator/Counter Specifications

Tracking Generator (8443A and 8443B)

- Frequency Range:** 100 kHz to 110 MHz.
Sweep Width: 18 selectable, calibrated sweep widths from 200 Hz to 100 MHz in a 2, 5, 10 sequence; controlled by spectrum analyzer.
Spectral Purity:
Residual FM: Determined by spectrum analyzer IF Section.
8552A: Less than 20 Hz peak to peak.
8552B: FM sidebands > 60 dB down 50 Hz or more from CW signal; typically less than 1 Hz peak to peak.
Amplitude Range: < -120 dBm to +10 dBm in 10 and 1 dB steps with a continuous 1.2 dB vernier.
Amplitude Accuracy:
Frequency Response (flatness): ± 0.5 dB.
Output Attenuators:
10 dB steps: ± 0.2 dB.
1 dB steps: ± 0.1 dB.
Calibration: 0 dBm at 30 MHz: ± 0.3 dB.
Output Impedance: 50 Ω , ac coupled, reflection coefficient ≤ 0.09 (1.2 SWR) output < 0 dBm.

Counter (8443A only)

- Display:** 7 digits with 1 digit over-range. Reads to ± 10 Hz increments.
Resolution (gate time): 1 kHz (1 ms), 100 Hz (10 ms), 10 Hz (100 ms).
Accuracy: ± 1 count \pm time base accuracy.
Time Base Aging Rate: $< 3 \times 10^{-9}$ /day after warm-up.
Time Base Temperature Drift: $< 3 \times 10^{-8}$ variation, 0-55°C.
External Inputs:
Counter: 10 kHz to 120 MHz, 50 Ω , -10 dBm min.
Time Base: 1 MHz, 50 Ω , 1 V rms min.
Auxiliary Outputs:
Time Base: 1 MHz, 1 V rms nominal.
Digital Frequency Output: 8, 4, 2, 1 code: "1" positive.
Modes:
Marker: Counter reads frequency of marker location on Spectrum Analyzer display. Marker position is manually variable or can be automatically switched to the center of the display.
Scan Hold: Scan starts at left edge of display and stops at marker. Counter measures frequency continually. Scan hold mode allows manual scan.
External: Counter measured frequency of signal at external counter input up to 120 MHz.

General (8443A and 8443B)

- Temperature Range:** Operation, 0 to 55°C; storage, -40°C to 75°C.
Power: 115 V and 230 V, 48 to 440 Hz. 8443A, 75 watts; 8443B, 45 watts.
Dimensions: Length, 18 3/8 in. (466.7 mm). Width, 16 3/4 in. (425.4 mm). Height, 3 7/8 in. (98.4 mm), including height of feet.
Net Weight: 8443A, 29 lb. (13.1 kg). 8443B, 24 lb., 12 oz. (11.2 kg).
Shipping Weight: 8443A, 35 lb. (15.9 kg). 8443B, 30 lb. (13.7 kg).
Price: 8443A, \$3,500.00
 8443B \$1,975.00
 Mod. Kit No. 11663A adds counter/marker to 8443B, \$1,525.00.

Modifications Required (8443A and 8443B)

The 8443A and 8443B are fully compatible with all 8553B RF Sections, 8552B or new 8552A IF Sections and 141T or 140T Display Sections. It is not compatible with the 143S Large Screen Display Section; however, special 143S Display Sections can be ordered.

Older spectrum analyzers may require modification kits for the RF, the IF, and the display section. The kits may be ordered separately from the service center or as options to the 8443 from the factory. The prices are the same in either case.

The sections that need to be modified are: all 8553L RF Sections, any 8552A IF Section with Serial Numbers 945-01889 and below, and all 140S or 141S displays. Kits are not available for the 143S Display Section.

Section	Modification Kits	
	With 8443A or 8443B from factory	From service center
8552A (S/N \leq 945-01889)	Option 101, add \$70.00	Mod. Kit 08552-6060 \$70.00
8553L	Option 102, add \$90.00	Mod. Kit 08553-6065 \$90.00
141S/140S	Option 103, add \$40.00	Mod. Kit 00140-69504 \$40.00
All Three Kits	Option 100, add \$200.00	—

SIGNAL ANALYZERS



SPECTRUM ANALYZER

High Resolution, 1 kHz to 110 MHz
Models 8553B/8552B

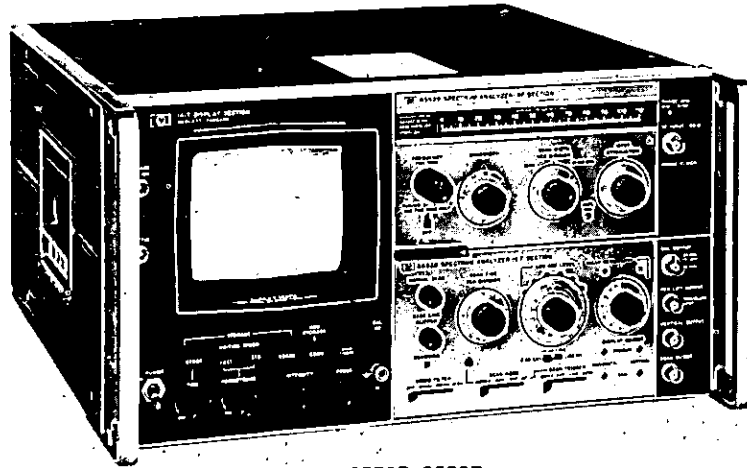

8553B/8552B

The HP 8553B/8552B is the first spectrum analyzer to combine high resolution analysis with wide scan capability. With a frequency range of 1 kHz to 110 MHz, the 8553B/8552B has the capability to scan as wide as 100 MHz or as narrow as 200 Hz. This single system allows wide band measurements of such phenomena as harmonic distortion or out-of-band emissions with the capability to "zoom-in" on a particular signal for modulation measurements or in-band distortion analysis.

High Resolution: The 8553B/8552B features 10 Hz equal signal resolution throughout the frequency range. More significant, such phenomena as line related sidebands may be resolved even when they are 60 dB or more below the carrier level. IF bandwidths as narrow as 10 Hz with 60 dB/3 dB shape factors less than 11:1 allow this high resolution capability.

High Stability: Accurate high resolution analysis requires an extremely stable measurement system. With residual FM less than 1 Hz, the 8553B/8552B becomes the stable reference necessary for full use of narrow bandwidth operation.

Absolute Amplitude Calibration: The spectrum analyzer has absolute amplitude calibration in addition to a fully calibrated display. Absolute signal levels in either dBm or voltage may be read directly from the CRT. External calibration signals are not required to obtain accurate amplitude information. Excellent ± 0.5 dB flatness across the full frequency range makes direct measurements accurate and simple.

70 dB Display: A dynamic display range of 70 dB, free from spurious and image responses, allows meaningful measurements over a wide amplitude range. Three display modes are provided on the spectrum analyzer: 10 dB per division logarithmic; 2 dB per division logarithmic; and linear display with selectable scale factors from 0.1 μ V per division to 100 mV per division.

High Sensitivity: Low level signals may be accurately characterized with ease due to the -140 dBm (25 nV) sensitivity of the spectrum analyzer. A wide measurement range from -140 dBm to +10 dBm provides great flexibility for a variety of measurements.

Variable Persistence Display: High resolution analysis requires slow scanning rates. These slow rates are made practical through the use of the 141T Variable Persistence Display Section which provides a flicker-free display at even the slowest scan rates. With normal persistence, the trace would appear merely as a slowly moving dot on the CRT. Trace storage is also provided on the 141T Display Section for side-by-side comparison of spectra.

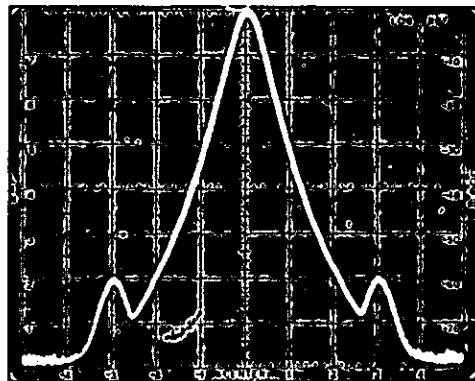

In many cases, complete characterization of system performance requires measurement of line related sidebands on output signals. In this photo, a receiver local oscillator was measured for stability and spectral purity. This oscillator was crystal controlled and had excellent frequency stability. The power supply used, however, produced considerable 60 Hz ripple, causing sidebands 60 dB below the oscillator output. (The 10 Hz IF bandwidth also permits measurement of 50 Hz sidebands.) The spectrum analyzer scan is 20 Hz per division centered at 30 MHz. The LOG REF level (top graticule line) is -20 dBm.

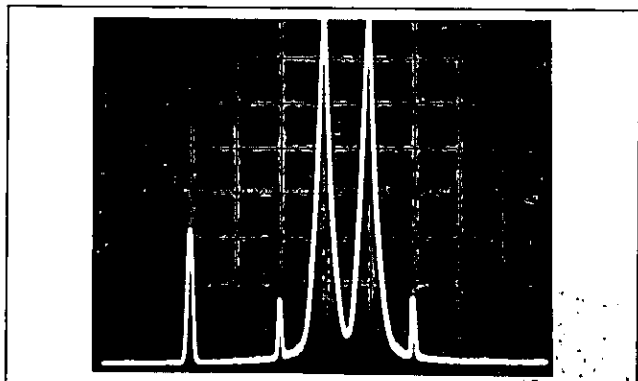

A two-tone intermodulation test was performed on a single sideband transmitter. The carrier appears at the left of the photo and is suppressed 47 dB below the sideband outputs. The transmitter was modulated by two audio tones at 600 Hz and 800 Hz. (The spectrum analyzer scan is 200 Hz per division centered at 1.3 MHz.) Third order intermodulation products can be measured 63 dB below the desired two-tone modulation. Expanding the scan, you could measure second order intermodulation products or harmonics of the carrier frequency being radiated by the transmitter.

Specifications

Frequency

Frequency Range: 1 kHz-110 MHz (0-11 MHz and 0-110 MHz tuning ranges).

Frequency Response (flatness): ± 0.5 dB, 1 kHz to 110 MHz.

Scan Width: (on 10 division CRT horizontal axis)

Per Division: 18 calibrated scan widths from 10 MHz/div to 20 Hz/div in a 1, 2, 5 sequence.

Preset: 0-100 MHz.

Zero: Analyzer is fixed tuned receiver.

Scan Time: 16 internal scan rates from 0.1 ms/div to 10 sec/div in a 1, 2, 5 sequence, or manual scan.

Resolution:

Bandwidth: IF bandwidths of 10 Hz to 300 kHz provided in a 1, 3 sequence.

Bandwidth Accuracy: Individual IF bandwidth, 3 dB points calibrated to $\pm 20\%$ (10 kHz bandwidth $\pm 5\%$).

Bandwidth Selectivity: 60 dB/3 dB IF bandwidth ratios: $< 11:1$ for IF bandwidths 10 Hz to 3 kHz, $< 20:1$ for IF bandwidths from 10 kHz to 300 kHz, 60 dB points separated by < 100 Hz for 10 Hz bandwidth.

Stability:

Residual FM:

Stabilized: Sidebands > 60 dB down 50 Hz or more from CW signal, scan time ≥ 1 sec/div, 10 Hz bandwidth.

Unstabilized: < 1 kHz peak-to-peak.

Noise Sidebands: More than 70 dB below CW signal, 50 kHz or more away from signal, with 1 kHz IF bandwidth, 10 Hz Video Bandwidth.

Amplitude

Absolute Amplitude Calibration Range:

Log: From -130 to +10 dBm, 10 dB/div on a 70 dB display; or 2 dB/div on a 16 dB display.

Linear: From 0.1 μ V/div to 100 mV/div in a 1, 2 sequence on an 8-division display.

Dynamic Range

Average Noise Level: < -110 dBm with 10 kHz IF bandwidth.

Spurious Responses: For -40 dBm signal level at the input mixer: * Image responses, out-of-band mixing responses, harmonic and intermodulation distortion are all more than 70 dB below the signal level at input mixer, * 2 MHz to 110 MHz; 60 dB, 1 kHz to 2 MHz. Third Order Intermodulation Products: For -40 dBm total signal level at input mixer, * third order intermodulation products are more than 70 dB down for input signals of 100 kHz to 110 MHz; signal separation > 300 Hz.

Residual Responses: 200 kHz - 110 MHz < -110 dBm, 20 kHz - 200 kHz < -95 dBm.

Input Impedance: 50 Ω nominal. Reflection coefficient < 0.13 (1.3 SWR), input attenuator ≥ 10 dB.

Maximum Input Level: Peak or average power +13 dBm (1.4 V ac peak), ± 50 V dc.

Calibrator Output:

Amplitude: -30 dBm, ± 0.3 dB.

Frequency: 30 MHz, ± 3 kHz.

Video Filter: Averages displayed noise; 10 kHz, 100 Hz, and 10 Hz bandwidths.

Display

Variable Persistence/Storage (Model 141T)

Cathode-ray Tube:

Type: Post-accelerator storage tube, 9000 volt accelerating potential; aluminized P31 phosphor; etched safety glass faceplate reduces glare.

Persistence:

Normal: Natural persistence of P31 phosphor (approximately 0.1 second).

Variable:

Normal Writing Rate Mode: Continuously variable from less than 0.2 second to more than one minute (typically to two or three minutes).

Erase: Manual; erasure takes approximately 350 ms; CRT ready to record immediately after erasure.

Storage Time: Normal writing rate; more than 2 hours at reduced brightness (typically 4 hours). More than one minute at maximum brightness.

Normal Persistence (Model 140T):

Cathode-ray Tube:

Type: Post-accelerator, 7300 volt potential medium-short persistence (P7) phosphor; tinted and etched safety glass faceplate reduces glare. (Normal persistence of P7 phosphor approximately 3 sec.)

General

EMI: Conducted and radiated interference are within requirements of MIL-I-16910C and MIL-I-6181D and methods CE03, and RE02 of MIL-STD-461 (except 35 to 40 kHz) when 8553B and 8552B are combined in a 140T or 141T Display Section.

Power Requirements: 115 or 230 volts $\pm 10\%$, 50 to 60 Hz, normally less than 225 watts.

Dimensions:

Model 140T or 141T Display Section: 9-1/5 in. high (including height of feet) x 16-3/4 in. wide x 18-3/8 in. deep (229 x 425 x 467 mm).

Model 143S Display Section: 21 in. high (including height of feet) x 16-3/4 in. wide x 18-3/8 in. deep (533 x 425 x 467 mm).

Weight:

Model 8553B RF Section: Net, 12 lb (5.5 kg). Shipping 17 lb (7.8 kg).

Model 8552B IF Section: Net, 9 lb (4.1 kg). Shipping, 14 lb (6.4 kg).

Model 140T Normal Persistence Display Section: Net, 37 lb (16.8 kg). Shipping, 45 lb (20 kg).

Model 141T Variable Persistence Display Section: Net, 40 lb (18 kg). Shipping, 51 lb (23 kg).

Model 143S Large Screen Display Section: Net, 62 lb (28.1 kg). Shipping, 81 lb (36.7 kg).

Accessory Required for Service: 11592A Service Kit, \$185.00.

Includes extender cables, connector adapters, etc.

Price:

Model 8553B RF Section	\$2,200.00
Model 8552B IF Section	\$2,850.00
Model 141T Variable Persistence Display	\$1,700.00
Model 140T Normal Persistence Display	\$ 875.00
Model 143S Large Screen Display	\$1,500.00

*Signal level at input mixer = Signal level at RF INPUT - INPUT ATTENUATION

SPECTRUM ANALYZERS *continued*

Model 8555A/8552A or
Model 8555A/8552B

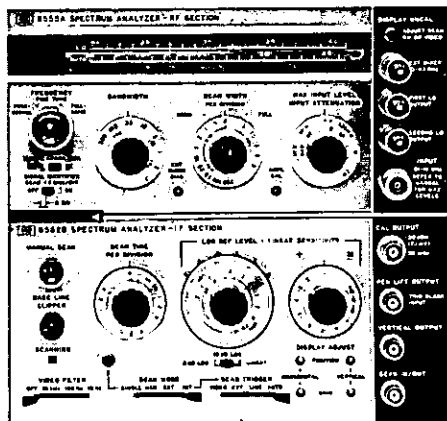

8555A/8552B

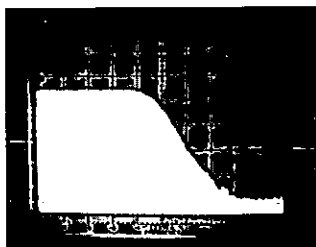

FIGURE 1. The flat frequency response of the 8555A makes it ideal for the measurement of the transmission characteristics of the 10 GHz low pass filter pictured above. Log reference level (top horizontal line in graticule): +20 dBm. Center frequency: 10 GHz. Scan width: 10 MHz/division.

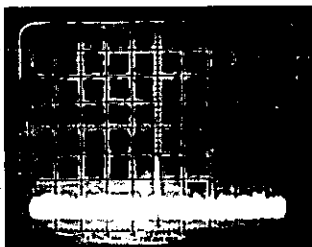

FIGURE 2. The high sensitivity of the 8555A allows the observation of very weak signals such as the distortion product of a microwave mixer as pictured above. The absolute peak amplitude of the signal is -110 dBm. Log reference level (top horizontal line in graticule): -60 dBm. Center frequency: 2.9 GHz.

Solid State Measurement System

The HP 8555A/8552A/8552B now offers absolute calibration both in amplitude and frequency at microwave frequencies. The 8555A RF sections operates over the wide frequency range of 10 MHz to 18 GHz with an internal mixer. With an external waveguide mixer, the frequency range is 12.4 to 40 GHz. The 8555A features a solid state, YIG-tuned, local oscillator. Solid state reliability ends the nuisance and expense of oscillator (BWO) replacement. The 8555A extends the current product line of absolutely calibrated RF sections for the 140T/141T (Mainframe) plug-in spectrum analyzer system. The other RF sections, 8553B and 8554L, cover the frequency ranges of 1 kHz to 110 MHz and 500 kHz to 1250 MHz respectively.

Two IF sections are available for the 8555A, the 8552A, and the high resolution 8552B. The 8552B incorporates all the features of the 8552A and in addition offers a 2dB log expand display mode, manual scan, and better resolution because of better IF filter factors. A choice of mainframe is also possible. The 141T mainframe adds the advantages of variable persistence and image storage to the advantages of the 140T.

Absolute Amplitude Calibration

The 8555A represents an advancement in the state of the art in offering absolute calibration over the frequency range of 10 MHz to 18 GHz. This is of particular importance in a harmonic mixing analyzer where gain is a function of mixing mode. In the 8555A, compensating amplifiers eliminate these gain variations. This makes possible the direct comparison and measurement of two signals on two different frequency bands. Figure 1 is the frequency response of a low pass filter. Because of absolute calibration, the vertical scale of the display can be read directly in dBm. Absolute calibration also allows the checking of absolute output levels of sources; the checking of saturation levels in mixers and amplifiers; and measuring distortion in amplifiers as a function of output level. For RFI and ECM analysis, field strength can be measured with a calibrated antenna. In addition, absolute calibration makes practically every spectrum analysis measurement easier and more convenient.

High Sensitivity

The high sensitivity of the 8555A is demonstrated in the accompanying display (Figure 2) of a spurious product of a microwave mixer. The peak amplitude of the distortion product is -110 dBm. A post detection filter with 10 kHz, 100 Hz, and 10 Hz (8552B only) positions average the noise and results in the extremely clean observed trace. High sensitivity makes it possible to measure large values of attenuation, out-of-band filter and amplifier response, weak transmitted signals in surveillance work, or microvolt signals in ECM applications.

SPECTRUM ANALYZERS *continued*

Model 8555A/8552A or
Model 8555A/8552B

High Resolution

The resolving capability of a spectrum analyzer is a measure of its ability to separate two closely spaced signals. It is largely determined by the analyzer IF bandwidth of 100 Hz and the residual FM, which is less than 100 Hz. The 8555A has more than enough capability to resolve 1000 Hz sidebands 35 dB down from the fundamental as shown in Figure 3. This resolution capability makes it possible to analyze spurious low frequency modulation of microwave signals. The high stability of the analyzer results in more accurate measurements of residual FM, long term frequency drift, phase noise, and spectral purity.

Wide Scan

The full scan mode results in a scan of the local oscillator from 2050 – 4050 MHz. In this mode of operation an inverted marker appears on the CRT baseline. The frequency tuning control positions the marker. The marker indicates the center frequency for other scan modes. The inherent advantages of a full scan mode are demonstrated in Figure 4. The fundamental output of a 500 MHz amplifier is displayed simultaneously with the higher order distortion products. The per division mode permits the more detailed analysis of observed signals. For example, a frequency of interest in a radiated spectrum can be identified with the inverted marker in the full scan mode and then studied in more detail by switching to the per division mode. In the per division mode, closely spaced signals can be resolved such as modulation sidebands and intermodulation products.

One-Step Identification

Identification of the frequency of an unknown signal is a simple one-step procedure with the 8555A. With the unknown signal in near center screen, the signal identifier switch is moved to the ON position. If the image on the CRT resembles the one engraved on the front panel under the signal identifier switch (See Figure 5), then the signal frequency can be read under the hairline on the frequency band scale. If the image observed differs from the one on the front panel engraving, the frequency band selection lever is repeatedly depressed until the desired image is observed.

Automatic Tuning Stabilization

In the automatic stabilization mode of operation, the local oscillator of the analyzer is locked to a crystal reference. This improves the overall stability of the analyzer from 10 kHz residual FM to 100 Hz. Stabilization circuitry is automatically enacted for scan widths of 200 kHz/div. and less when the stabilization switch is in the position indicated in Figure 6. The lettering on the scan width control up to 200 kHz/div. and the stabilization switch is colored blue to remind the user of the scan range over which stabilization occurs.

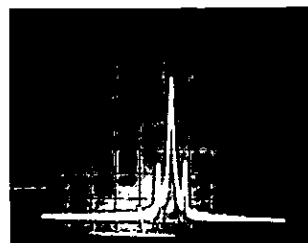

FIGURE 3. The 8555A is capable of resolving low frequency sidebands (1 kHz) which are weak in amplitude (-35 dB) in comparison to the fundamental. Center frequency: 450 MHz. Scan width: 2 kHz/division.

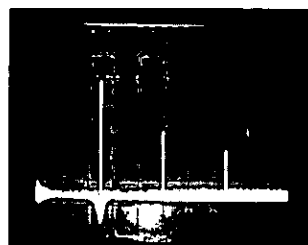

FIGURE 4. The full scan mode of the analyzer allows the simultaneous observation of several signals spaced widely apart in frequency such as the fundamental and the 2nd and 3rd order distortion products of a 500 MHz amplifier pictured above. An inverted marker which appears in this mode is positioned under the fundamental.

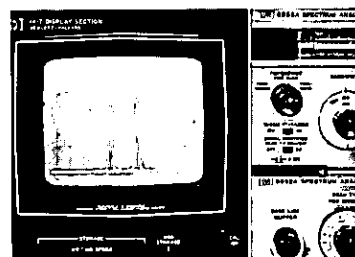

FIGURE 5. The signal frequency can be read under the hairline of the frequency band scale, when the image in the center of the CRT splits into the two observed above with the signal identifier on.

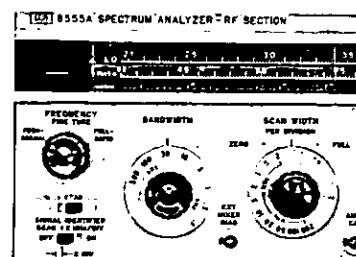

FIGURE 6. Stabilization circuitry is enacted with a simple throw of the tuning stabilizer switch.

SPECTRUM ANALYZERS *continued*

Model 8555A/8552A or
Model 8555A/8552B

Specifications**8555A/8552A/8552B****Frequency Specifications****Frequency Ranges****Tuning Range**

With internal mixer: .01-18.00 GHz

With external mixer: 12.4-40 GHz

Selectable continuous coarse (by means of push-pull knob) and fine tuning determine display center frequency.

Frequency Accuracy

Dial Accuracy: $\pm n \times 15$ MHz where n =mixing mode.

Scan Accuracy: Frequency error between two points on the display is less than 10% of the indicated separation.

Stability: Total Analyzer Residual FM

Stabilized	Unstabilized
<100 Hz peak to peak	<10 kHz peak to peak

(first LO residual FM typically less than 30 Hz peak to peak)

Noise Sidebands: For fundamental mixing. More than 70 dB below CW signal, 30 kHz or more away from signal, with 1 kHz IF bandwidth and 100 Hz video filter.

Resolution

Bandwidth Ranges: IF bandwidths of .10 to 300 kHz provided in a 1, 3 sequence.

Bandwidth Accuracy: Individual IF bandwidth 3 dB points calibrated to $\pm 20\%$. (10 kHz bandwidth $\pm 5\%$.)

Bandwidth Selectivity:

IF Bandwidth	60 dB / 3 dB Bandwidth Ratio	
	8552A	8552B
10 kHz - 300 kHz	20:1	20:1
1 kHz - 3 kHz	20:1	11:1
.1 kHz - .3 kHz	25:1	11:1

Amplitude Specifications**Absolute Calibration Range****Measurement Range**

Log Reference Level: From -130 dBm to +10 dBm, in 10 dB steps. Log reference level vernier, 0 to -12 dBm continuously.

Linear Sensitivity: From .1 μ V/div. to 100 mV/div. in a 1, 2 sequence. Linear sensitivity vernier 1 to .25 attenuation ratio continuously.

Sensitivity

Average Noise Level: Specified for 1 kHz bandwidth. Using lower bandwidths will improve average noise level; e.g., use of 100 Hz bandwidth will improve noise level in the 1.5 to 3.55 GHz frequency range from -117 dBm to -127 dBm max.

With Internal Coaxial Mixer

Frequency Range	Mixing Mode n	IF Freq. MHz	Average Noise Level
.01 to 2.05 GHz	1-	2050	-115 dBm max.
1.50 to 3.55 GHz	1-	550	-117 dBm max.
2.07 to 6.15 GHz	2-	2050	-108 dBm max.
2.60 to 4.65 GHz	1+	550	-117 dBm max.
4.11 to 6.15 GHz	1+	2050	-115 dBm max.
4.13 to 10.25 GHz	3-	2050	-103 dBm max.
6.17 to 10.25 GHz	2+	2050	-105 dBm max.
6.19 to 14.35 GHz	4-	2050	-95 dBm max.
8.23 to 14.35 GHz	3+	2050	-100 dBm max.
10.29 to 18.00 GHz	4+	2050	-90 dBm max.

Residual Responses: Referred to signal level at input mixer on fundamental mixing: < -90 dBm.

Display Range

Log: 70 dB, 10 dB/div. with 8552B 2 dB/div. log expand on a 16 dB display.

Linear: From .1 mV to 100 mV/div. in a 1, 2 sequence on an 8-division display.

Display Uncalibrated Light: Panel light warns operator of uncalibrated amplitude display if selected IF or video bandwidth is too narrow for combination of scan width and scan time selected.

Input Attenuator Range

0-50 dB in 10 dB steps.

Absolute Calibration Accuracy

The overall absolute calibration accuracy of the spectrum analyzer in a particular application is a function of the measurement technique. The following elements also affect absolute calibration accuracy:

Frequency Response: With 10dB input attenuator setting.

Frequency Range	Mixing Mode n	IF Freq. MHz	Freq. Response
.01 - 2.05 GHz	1-	2050	± 1.0 dB max.
1.50 - 3.55 GHz	1-	550	± 1.0 dB max.
2.07 - 6.15 GHz	2-	2050	± 1.0 dB max.
2.60 - 4.65 GHz	1+	550	± 1.0 dB max.
4.11 - 6.15 GHz	1+	2050	± 1.0 dB max.
4.13 - 10.25 GHz	3-	2050	± 1.5 dB max.
6.17 - 10.25 GHz	2+	2050	± 1.5 dB max.
6.19 - 14.35 GHz	4-	2050	± 2.0 dB max.
8.23 - 14.35 GHz	3+	2050	± 2.0 dB max.
10.29 - 18.00 GHz	4+	2050	± 2.5 dB max.

Input RF Attenuator: Frequency response typically no worse than $\pm .6$ dB from 10 MHz to 18 GHz.

Amplitude Display: Log $\pm .25$ dB/dB but not more than ± 1.5 dB over the full 70 dB display range.

Linear: $\pm 2.8\%$ of full 8-division deflection.

Input Specifications

Input Impedance: 50 ohms nominal (.01-18 GHz).

RF Input Connector: Type N female.

General Specifications

Power Requirements: 115 or 230 volts $\pm 10\%$, 50-60 Hz, normally less than 225 watts (varies with plug-in units used).

Dimensions: Model 140T or 141T Display Section, 9-1/16 inches high (including height of feet) x 16-3/4 inches wide x 18-3/8 inches deep (229 x 425 x 467 mm).

Weight: Model 8555A RF Section: Net, 14 lb., 15 oz. (6.8 kg).

Shipping, 19 lb. (8.7 kg).

Model 8552A IF Section: Net, 9 lb. (4.1 kg).

Shipping, 14 lb. (6.4 kg).

Model 8552B IF Section: Net, 9 lb. (4.1 kg).

Shipping, 14 lb. (6.4 kg).

Model 140T Display Section: Net, 37 lb. (16.8 kg).

Shipping, 45 lb. (20 kg).

Model 141T Display Section: Net 40 lb. (18 kg).

Shipping, 15 lb. (23 kg).

Model 143S Display Section: Net, 62 lb. (28.1 kg).

Shipping, 81 lb. (36.7 kg).

Price:

Model 8555A RF Section \$5,975.00

Model 8552A Standard IF Section \$2,150.00

Model 8552B High Resolution IF Section \$2,850.00

Model 140T Normal Persistence Display \$ 875.00

Model 141T Variable Persistence Display \$1,700.00

Model 143S Large Screen Display \$1,500.00

System = RF + IF + Display Sections

IF Sections	Display Sections		
	140T	141T	143S
8552A	\$9000	\$9825	\$9625
8552B	\$9700	\$10525	\$10325

AUTOMATIC SPECTRUM ANALYZER

Model 8580A



SIGNAL ANALYZERS

Description:

The 8580A Automatic Spectrum Analyzer is a flexible measurement system for applications in surveillance and network characterization from 10 kHz to 18GHz. This system consists of a variety of programmable instruments that are controlled from a small instrumentation computer. The measurement heart of the system is a calibrated receiver with programmable tuning and bandwidth. This receiver can be tuned from 10 kHz to 18 GHz by simple one line statements in BASIC or FORTRAN measurement programs. Receiver bandwidth is similarly selectable from 300 Hz to 300 kHz. Other programmable system functions include input selection (up to 8 ports) and sensitivity (down to -130 dbm).

Optional signal sources expand the capability of the 8580A system. Precision RF sources with programmable level and frequency supply signals required to excite test devices for network analysis measurements. Programmable DC power supplies are available for bias or control ports of test devices.

The digital portion of the system includes all interface electronics to operate the programmable instruments from the system's 8K or 16K word computer. The wide range of optional computer peripherals available with the 8580A include teleprinters, photoreaders, high speed punched output, large screen display, X-Y recorder, magnetic tape, and line printer. Software supplied allows all programmable functions of the component instruments and peripherals to be exercised from either BASIC or FORTRAN language programs.

Programming:

The 8580A's software package is designed to make specialized programs easily user written. The system is supplied with subroutines that can be called from BASIC or FORTRAN language applications programs to control instrument functions and search frequency bands to record signals present. Representative statements are listed below:

- CALL TUNE (F): tunes receiver to frequency F
- CALL BWIDTH (10): sets system bandwidth to 10kHz
- CALL MEAS (A): returns signal level in absolute power
- CALL PEAK (10,30,F1, A1): searches between 10 and 30 MHz and finds frequency and amplitude of largest signal present.

Applications:

The 8580A Automatic Spectrum Analyzer is a valuable tool for gathering spectral density data on the signals present around or inside complex electronic equipment or in a geographic region. RFI testing, for example, is enhanced by the automatic systems ability to correct for sensor transfer function and compare measured data against specification limits. Performance of a complex communication network (longline or microwave link) can also be continually monitored to report network performance on a regular basis. Similarly, radiation in a particular locale can be surveyed to gather statistics on available spectrum or unauthorized transmissions. These applications emphasize an important feature of the Automatic Spectrum Analyzer: totally unattended operation.

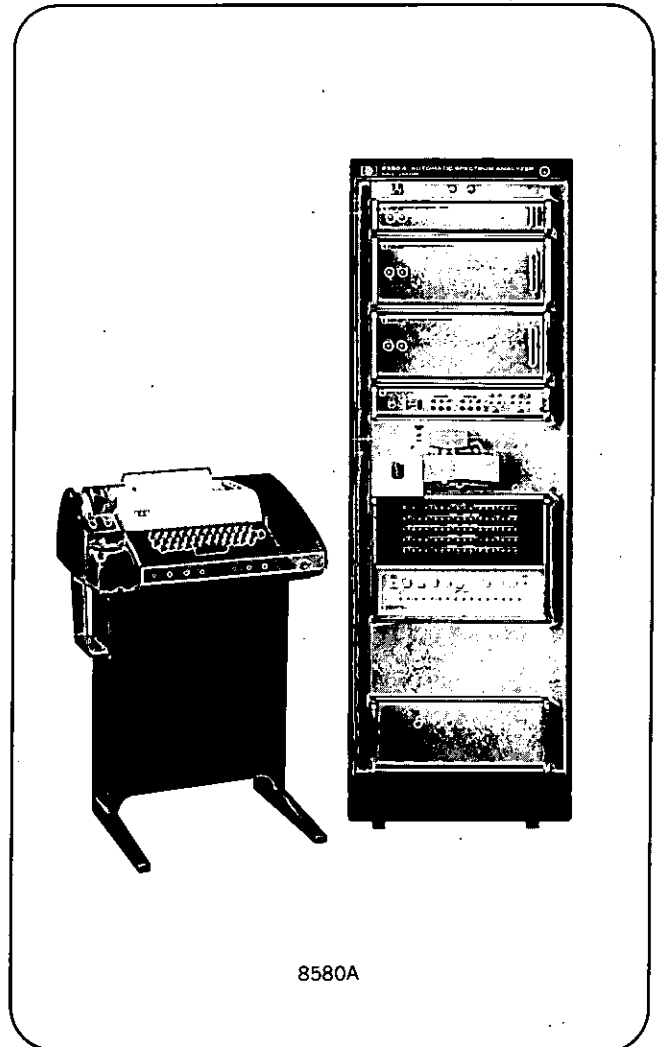

The 8580A may be programmed to measure, analyze, and record results, and hence run without human intervention, for long periods. This makes comprehensive monitoring a practical tool for spectrum management.

Network characterization is also greatly advanced through use of an Automatic Spectrum Analyzer. Not only may the magnitude of reflection and transmission coefficients of linear networks be determined, but also the distortion parameters (harmonic, intermodulation, cross-modulation) of non-linear devices such as amplifiers can be measured. Frequency translators such as mixers, modulators, and frequency multipliers are also readily characterized. Additionally, oscillators can be evaluated for output level, distortion, and spurious output signals.

For both surveillance and network characterization applications, the 8580A's absolute calibration (frequency and power), broad frequency coverage, wide measurement range, speed, and ease of programming, combined with the flexible hardware option list, offer a measurement system that can be tailored to your application. Consult your local Hewlett-Packard office for complete technical information.

SIGNAL ANALYZERS



NUCLEAR ANALYZER SYSTEMS

Computer versatility and calculator economy

Models 5402A, 5403A

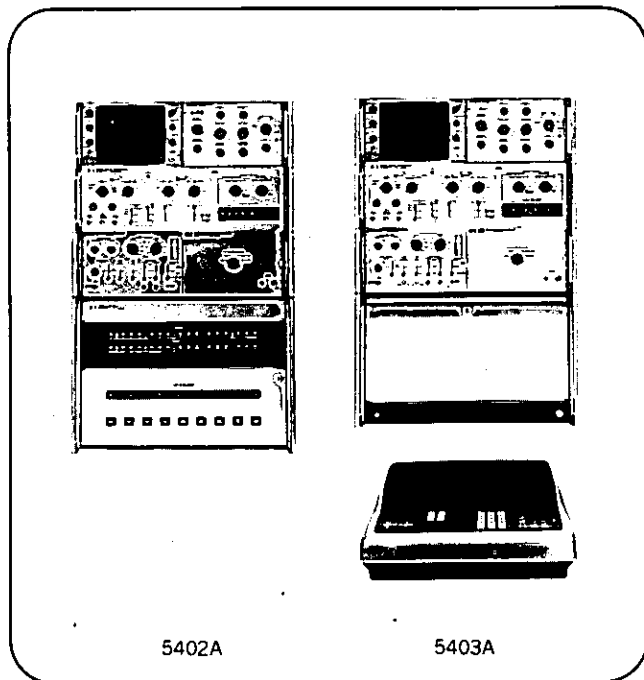

5402A — MCA/Basic System

BASIC Computer Language Control over analyzer operations and data reduction
 Complete On-line Data Reduction Capability
 Combination of: multichannel analyzer, general purpose computer
 Automatic Operations Programmable in BASIC

The HP 5402A MCA/BASIC System combines the nuclear measurement capability of the HP 5401B Multichannel Analyzer with the data handling capability of an HP Computer under BASIC Language control. The result—a system capable of on-line data processing beyond that offered in any other analyzer-computer combination.

BASIC Language is the key to flexible control, data reduction, and automatic operation with a minimum of operator training. Instructions in BASIC are "conversational" and provide control of: Erase; Accumulate; Display; Data Transfer to and from Teleprinter, Paper Tape Peripherals, Magnetic Tape, and Computer. And, in addition, all the mathematic operations of BASIC are available for processing the data.

The 5402A eliminates the need of taking the data to a large computer facility for reduction; all the capability is on line. Whether the need is for an automated system that operates unattended or for a developmental system to fill a unique application need, the 5402A provides the capability.

Brief Specifications, 5402A

Multichannel Analyzer: 5401B Specifications (see p. 35, 1970 HP Catalog or data sheet).

Computer: HP 2114 Computer having an 8192 by 16-bit word or larger memory capacity or optionally any Hewlett-Packard Computer with an 8192 by 16-bit word memory can be used in 5402A System.

Interface: Consists of the 10610A Interface Kit for the 5422B Digital Processor and the 12566B Microcircuit Interface Card for the computer.

5402A Basic Controls

Function Selection: Erase, Accumulate, Display, Output (parallel BCD), Output (serial BCD), Input (serial BCD), Interlaced Full Memory Display, and Transfer (Region A to Region B)

Start

Stop

MCA/Computer Data Transfer

MCA Status Check

Paper Tape Output (Data from the Computer)

Paper Tape Input (Data to the Computer)

Teleprinter Input/Output (Data to/from the Computer)

Magnetic Tape Input/Output (Data to/from the Computer)

Price and ordering information: please consult your local HP office.

5403A MCA/Calculator System

9100 Calculator provides control of: Multichannel Analyzer operation, data reduction, and data transfer.

On-line Data Reduction

Keyboard Programmable for Automatic Operation

Combination of: Multichannel Analyzer, Calculator, and Controller

The 5403A MCA/Calculator System provides a capability not available before: a nuclear measurement system using an electronic calculator for multichannel analyzer control, system control, and data reductions. Combined in the 5403A are the HP 5401B Multichannel Analyzer, 2470A Coupler/Controller, and 9100 Calculator. This combination affords maximum data reduction and control at minimum price.

Nuclear measurements can be performed manually or automated using the programmability of the 9100 Calculator and flexibility of the 2570A Coupler. Peripherals to the 2570A can be peripherals to the 5403A System. This includes the Hewlett-Packard 2752A and 2754A Teleprinters, 2748A Paper Tape Reader, and 2753A Paper Tape Punch. General purpose interfaces to the 2570A are also available.

Programs for the 5403A (sets of 9100 keyboard instructions) can be used to control automatic operations that combine: data accumulation, data display, data transfer to/from 9100, data reduction, and data transfer to/from 2570A peripherals. And no special programming training is necessary.

Now there is an alternative to using a general purpose computer in nuclear systems; an alternative that provides the same capability.

Brief Specifications, 5403A

Multichannel Analyzer: 5401B Specifications (see p. 35, 1970 HP Catalog or data sheet).

Calculator: 9100A (or optionally the 9100B) can be used.

Interfaces: 2570A provides an I/O Card Cage for 5401B and 9100 Interface cards. Peripherals to the 5403A interface to either the 2570A or the 5410A Interface of the 5401B Multichannel Analyzer.

5403A MCA Controls: Erase, Accumulate, Display, Serial BCD output through 5401B, Serial BCD input directly to 5401B, Transfer Region A to Region B, Start, Stop, and MCA Status Check.

System Controls: Transfer 5401B Data to/from 9100, and Transfer 5401B Data to/from 2570A Peripheral.

Price and ordering information: please consult your local HP office.

NUCLEAR ANALYZER SYSTEM

Software-oriented for greater flexibility

Model 5406B



SIGNAL ANALYZERS

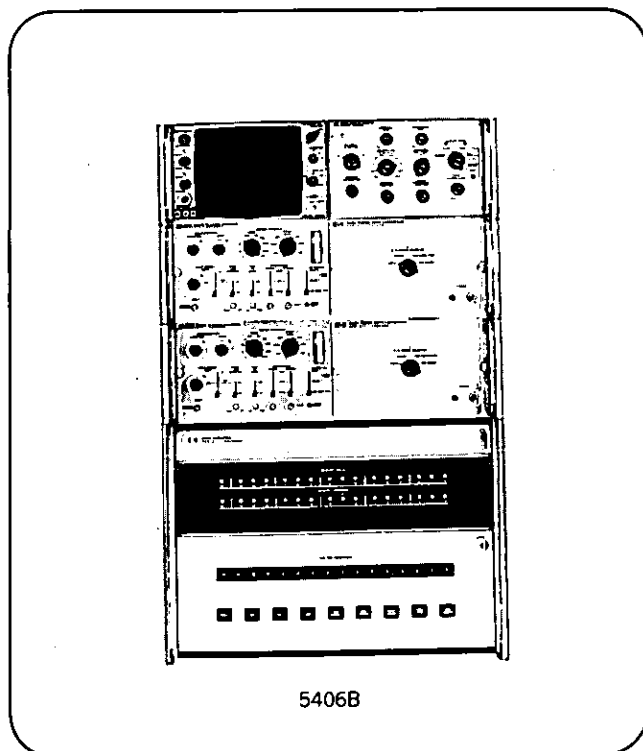

5406B

FEATURES

Combination of Pulse Height Analyzer and General Purpose

Computer System:

- 8192 Channel Analog-to-Digital Converter
- Choice of Display Subsystems
- Executive Software System
- Up to 32,000 16-Bit Words of Memory
- Data channel size can be 16, 20, 24, or 32 bits
- Up to 32 I/O Slots with Interrupt Priority
- Wide Range of Peripheral Devices
- 4 Programming Languages

Software Control of:

- Single Parameter Analysis
- Multiparameter Analysis with Digital Gates or Delayed Time Totalizing
- Multiple ADC Operation
- Data Reduction
- Automatic System Operation

Completely Modular Design:

- Hardware Expandable for Special Systems
- Software Expandable for Special Applications

Hewlett-Packard Designed, Manufactured, and Supported Hardware

Proven, Supported Software

The Hewlett-Packard 5406B Nuclear Analyzer System is a computer-based pulse height analyzer system designed around the Hewlett-Packard General Purpose Computers and the Hewlett-Packard 5416B Nuclear Analog-to-Digital Converter. An integral part of the design is the Executive Software System. It is this proven software package and the flexibility of the computers that give the 5406B its versatility.

Although the 5406B System was designed as a pulse height analyzer and its option list supports this use, there have been no restrictions placed on the computer that interfere with its

general purpose use. A large number of computer compatible instruments and digital peripherals are available from Hewlett-Packard which are not offered as standard options to the 5406B, but most can be integrated into a 5406B System to form a special or custom system. Many unique, custom systems can be based on the 5406B.

The Executive Software System is modular. It consists of a set of subroutines controlled by an Executive program. The library of subroutines provided with each system includes the following functions:

- 6 Data Accumulation Control subroutines (includes digital gates and delayed time totalizing)
- 2 Data Display Subroutines
- Control subroutines for standard options
- Data reduction subroutines
- Automatic Control subroutines

Subroutines written in ALGOL, FORTRAN, or Assembler Language can be added to the Subroutine Library and placed under Executive control very simply.

There is a wide range of applications for the 5406B because of its modular design; all types of pulse height analysis are possible:

- single parameter pulse height analysis
- multiparameter analysis with digital gates or delayed time totalizing
- multiple ADC operation

And the 5406B is not limited to nuclear applications; it is an excellent system for any application that requires very accurate, stable analog-to-digital conversion and computer control.

5406B System:

- HP Computer with 8192 (or larger) memory
- 2752A Teleprinter with 12531B Interface
- 5416B Analog-to-Digital Converter
- 5410A Power Supply
- ADC-Computer Interface (includes 12566A Interface)
- H51-180AR Oscilloscope Mainframe
- 5430A Display Plug-in for H51-180AR
- 12554A Interface Cards (2 each)
- Executive Software System
- Standard Computer Software

Optional Equipment:

- Memory Expansion
- 2754A Heavy Duty Teleprinter
- 2748A Paper Tape Reader
- 2753A Paper Tape Punch
- 7970A Magnetic Tape System
- Additional ADC Subsystems
- H51-181AR Storage Oscilloscope Mainframe
- Selection of Interfaces for 5416B ADC
- Special purpose options that include a variety of HP instruments and computer peripherals.

Executive Software System:

- System Operating Tape
- Prepare Executive Tape
- Question/Answer Tape
- Subroutine Library Tape
- Basic Control System Tape

All software is provided on punched paper tape configured for the peripheral devices included in the 5406B System and ready to use when the system is delivered.

Price: Please consult H.P. for price based upon options needed.



FOURIER ANALYZERS

Vibration, Sonar, Acoustic, Biomed Analyses
Models 5450A and 5452A

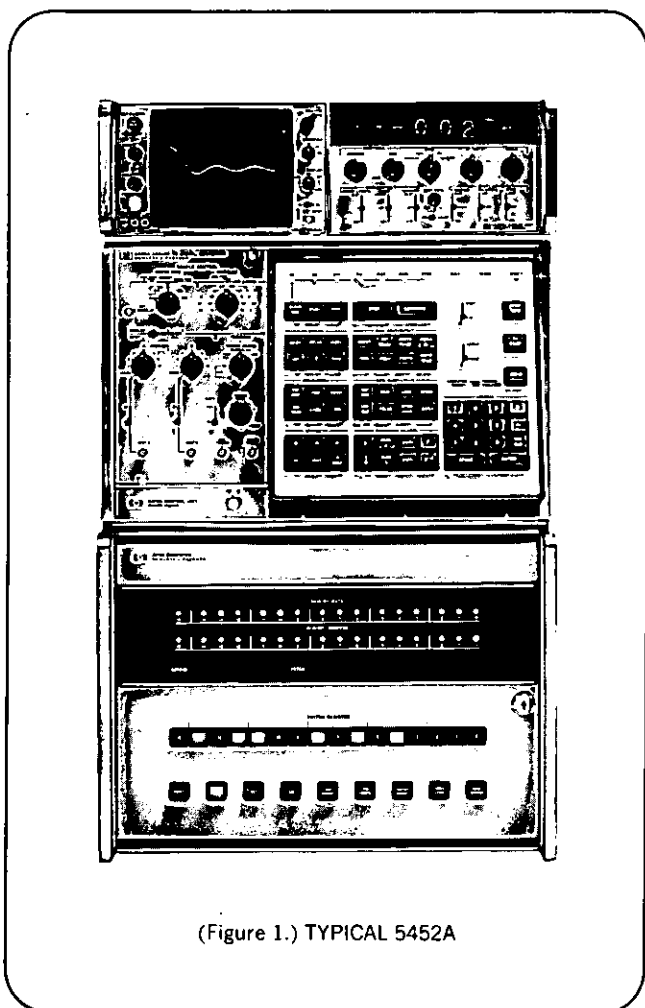

(Figure 1.) TYPICAL 5452A

Calculations at the touch of a button:

- Transfer and Coherence Function
- Auto and Cross Power Spectrum
- Auto and Cross Correlation
- Time or Frequency Averages
- Histograms
- Many others

Features:

- Dual Channel Input
- Digital Computation
- Keyboard Control
- Automatic Operation
- Complex Arithmetic

The 5450A and 5452A solve a wide range of complex statistical measurement tasks by converting from the time domain to the frequency domain and vice versa using the Fast Fourier Transform. A notably wide range of data manipulations are possible, all absolutely and automatically calibrated, all executed by merely pressing the appropriate button. For full details, request 5450A and 5452A Data Sheets and the Hewlett-Packard Journal, June 1970.

Computer Compatibility

Analysis is performed digitally in one of two HP computers — the 2114B/C in the 5452A and the 2116B/C in the 5450A. The Fourier Analyzers can be added to an existing HP computer. The 2115A-8K Computer can also be used with the 5450A.

Keyboard Operation

The flexibility of the computer is utilized but no computer knowledge is required — the applications keyboard controls all operations. From the keyboard, signals can be synthesized, data can be manipulated, input/output operations can be controlled, automatic measurement routines written, and many other operations controlled.

Software

A complete Fourier software package is provided. Once it is loaded, no software knowledge is required. But, user written software routines can be written into the Fourier program, if desired, to perform a specialized task. In addition, by flipping a keyboard switch, the computer can be used as a general purpose computer.

Calculations

In addition to providing the Forward and Inverse Fourier transforms at the push of a button, real and complex arithmetic; integration and differentiation, linear and quadratic Hanning, correlation, convolution, and other functions are possible from the keyboard. By grouping several of these functions together a wide variety of operations and applications are possible. For example, if a time signal is Fourier transformed and complex multiplied with itself, the auto power spectrum results.

Input/Output Flexibility

Data inputs can be through the 10 bit analog-to-digital converter (one or two channels selectable), the high speed photoreader¹, teletype, keyboard, from another computer through the binary input/output channel², digital magnetic tape² or disc². The mag tape or disc can be used to do real time data logging if desired. Results are displayed on the CRT and can be in time, frequency (or amplitude), linear or log, real and imaginary, real versus imaginary (Nyquist plot) or magnitude and phase coordinates. Data can also be printed out, punched out, plotted², recorded on digital magnetic tape or disc², or transferred to another computer².

Automatic Operation

The various operations of the Fourier Analyzers can be executed either manually or automatically. A complete measurement routine can be executed automatically. Thus, various types of averaging routines for time or frequency averaging are easily performed. Six editing keys provide on-line editing so that changes in an automatic routine can be performed without off-line compiling or testing.

Training And Service

Training is included in the purchase price of either system. A three day course in Fourier analysis and instrument operations is offered at our Santa Clara Division. When a computer is ordered with the system, a two week computer training course is also included. Service is provided by the world-wide service facilities of Hewlett-Packard.

Typical Systems

5452A consisting of:

- 5460A Display Plug-in
- 5465A Analog-to-Digital Converter
- 5475A opt. 002 Keyboard
- H51-180AR Oscilloscope Mainframe
- 2752A Teleprinter and Interface Card
- 2114B 8K Computer
- 12566A Microcircuit Cards (2 each)

Price: \$30,500.

¹Optional on 5452A

²Optional

5450A consisting of:

5460A Display Plug-in
 5465A Analog-to-Digital Converter
 5475A opt. 001 Keyboard
 H51-180AR Oscilloscope Mainframe
 12566A Microcircuit Interface Cards (2 each)
 2116B 8K Computer with Extended Arithmetic Unit
 2940A Two Bay 56" Cabinet
 2752A Teleprinter
 2748A High Speed Photoreader

Price: \$50,770.

Partial Specification**Analog Input**

The Analog-to-Digital Converter (ADC) accepts one or two inputs. In two-channel operation both inputs are sampled simultaneously. Resolution of the ADC is 10 bits.

Amplitude Range: 0.1 V to 10 V maximum in steps of 1, 2, 4, 10.

Sensitivity: 30 μ V rms (sine wave).

Input Coupling: Ac or dc.

Input Impedance: 1 M Ω \pm 1% shunted by 45 pF max.

Linearity: Integral, \pm 0.05%; Differential, \pm 3%.

Trigger Modes: Slope and level controls are provided. The trigger input can be ac or dc coupled.

Internal: ADC triggers on signal to Channel A.

External: ADC triggers on signal applied to external input.

Line: ADC triggers on power line frequency.

Free Run: ADC triggers on data request from Digital Processor.

Trigger Output: Pulse output available on trigger.

Display Unit

Data may be displayed on the 8 x 10 cm oscilloscope or output to a plotter or remote oscilloscope.

Amplitude Scale: Data in memory is automatically scaled to give a maximum on-screen calibrated display. The scale factor is given in volts/division, volts²/division, or in dB offset.

Linear Display Range: \pm 4 divisions with scale factor ranging from 1×10^{-150} to $5 \times 10^{+150}$ in steps of 1, 2, 5, and 10.

Log Display Range: 4 decades with a scale factor ranging from 0 to \pm 998 dB.

Computational Speed

	5450A	5452A
Fourier Transform:		
Block Size 128:	104 ms	150 ms
Block Size 1024:	1.4 s	1.9 s

Keyboard Unit

There are 64 keys divided into eight major groups on the Keyboard Unit.

The Transform Related and Arithmetic groups include:

Fourier Transform
 Inverse Fourier Transform
 Correlation
 Convolution
 Linear Hanning
 Quadratic Hanning

Division (Block or Integer)
 Multiplication (Block or Integer)
 Conjugate Multiplication
 Addition
 Subtraction
 Integration
 Differentiation

Digital Accuracy And Resolution

All calculations use floating point arithmetic on a block basis. Data overflow does not occur. Amplitude resolution is 1 part in 16,000 worst case.

Data Memory Size: 3,072 words (8,192 for a 16,384-word memory).

Data Block Size: Any power of 2 from 128 to 1,024 (from 64 to 4,096 with 16,384-word memory).

Data Word Size: 16-bit real and 16-bit imaginary or 16-bit magnitude and 16-bit phase.

Computational Range: \pm 150 decades.

Transform Accuracy: 0.1% worst case error during the forward or inverse calculation. 0.5% worst case in 5452A.

Spectral Resolution

The element of spectral resolution is the frequency channel width, the maximum frequency divided by 1/2 the data block size.

Maximum Frequency: 25 kHz single channel; 10 kHz dual channel. Adjustable in steps of 1, 2.5, 5, and 10 down to 0.5 Hz.

Dynamic Range: 4 decades over \pm 150 decades.

Frequency Accuracy: \pm 0.01%.

Time Domain Resolution

The element of time resolution is the time channel width, the time sample record length divided by the block size.

Maximum Sample Record Length: Product of data block size and time channel width. (In Ensemble Averaging up to 32,767 Sample Record Lengths may be used for a statistical estimate.)

Time Channel Width: 20 μ s, single channel; 50 μ s, dual channel, up to 5 s in steps of 1, 2, 5. Accuracy 0.01%.

Input

Analog-to-Digital Converter
 (one or two channel)

Photoreader
 Teletype
 Keyboard
 Digital Mag Tape
 Disc
 Remote Computer

Output

Oscilloscope
 Plotter
 Teletype
 High Speed Punch
 Digital Mag Tape
 Disc
 Remote Computer

Power Requirements

Power Source: 115/230 V \pm 10%, 50/60 Hz.

Environmental Conditions: 0°C to 55°C using 2116B/C Digital Processor (10°C to 40°C using 2114B/C Digital Processor).

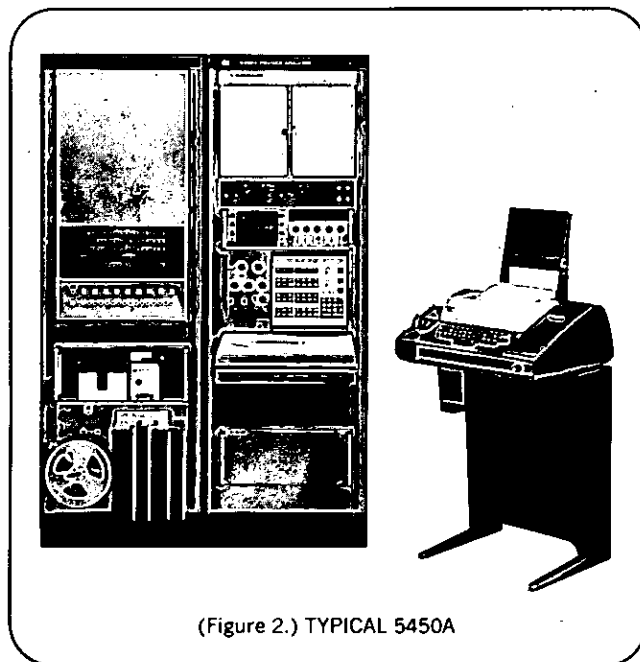

(Figure 2.) TYPICAL 5450A

SIGNAL ANALYZERS



SIGNAL ANALYZER SYSTEM

Averaging, histograms, measurement control
Models 5480S, 5481A

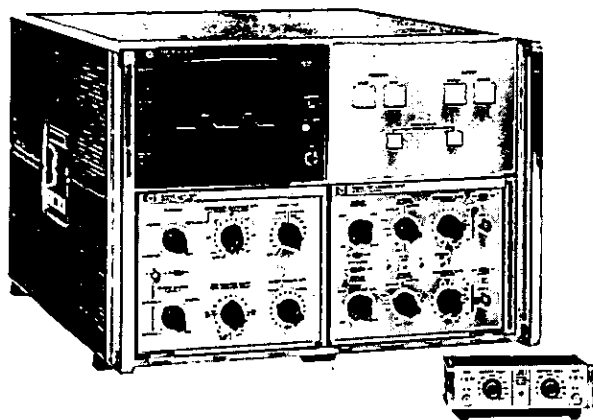

5480S

(5489A)

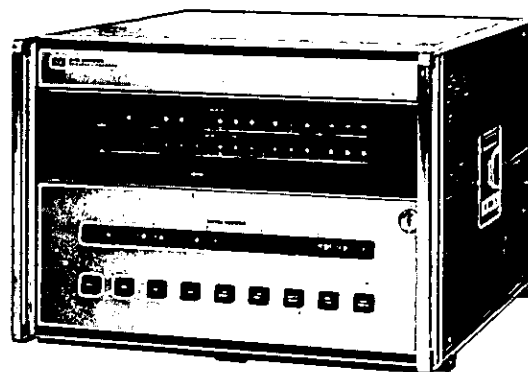

2114B

5480S Signal Analyzer System

Averaging provides an unparalleled method of recovering a signal buried in background noise. Featuring flicker free display, true and weighted averaging, and real-time variance, the 5480S brings a new dimension to signal recovery for general signal-to-noise problems in electronics, for enhancing the performance of spectrum and network analyzers and sampling oscilloscopes*, for spectroscopy in chemistry, physics, and geology, and for evoked response-stimulus testing in bio-medicine.

True Averaging: Display always represents true average calibrated in volts per centimeter; the display does not "grow" as in conventional summation but remains stable as the noise disappears.

Flicker free: Continuous display for all sweep speeds allows viewing the accumulated data while acquisition takes place.

Variance: The statistical variance is a measure of the variability of a signal. The 5480S gives you, point by point, real-time variance which allows you to spot variations in your signal or tells you exactly when the display represents the true average.

Weighted Averaging: A time varying signal may be observed in this mode which exponentially de-emphasizes old information in favor of new.

Histograms: The 5480S provides time interval and frequency probability density functions. Adding the 5326B Counter-Timer-DVM extends this capability to include amplitude, dwell, and latency histograms.

Multiple Inputs, Correlation: The 5485A Two Channel Input and the 5487A Four Channel Input plug-ins offer multiple channel capability. The 5488A Correlation/Average Input permits auto- and cross-correlation of signals as well as two input channels for averaging.

Input Filtering: Each 5480S System includes the 5489A Two Channel Input Filter; in addition to removing high frequency noise to reduce averaging time, the X10 gain provided by the 5489A increases resolution:

*Application Note 127.

5481A Signal Analyzer System

Combining the 5480S with the HP 2114B Digital Computer permits extensive on-line analysis of gathered data. Fourier transforms, power spectra, curve integration, smoothing, and differentiation, and many other data manipulating functions are possible. Or the 5481A System may be used for automating your other instrumentation providing you with multiplexed analog to digital conversion, display output on built-in 5480 oscilloscope, a 1000 word buffer memory, and controlling software.

5489A Low-Pass Filter

The 5489A Low-Pass Filter provides two independent, low pass active filters. Each channel also permits amplification of 20 dB as well as unity gain. Ten cutoff frequencies for each channel are in 1, 3 steps from 1 Hz to 30 kHz. Roll-off is 12 dB per octave or the "Filter Out" setting may be used. For steeper roll-offs or greater gain, the channels may be cascaded allowing 40 dB of gain or a 24 dB per octave attenuation slope.

Prices

All 5480S Signal Analyzer Systems include the 1024 word, 24 bit Memory/Display mainframe, the 5486B Control Plug-in, and the 5489A Two Channel Low-Pass Filter/Amplifier; the digitizing plug-in is chosen by option.

5480S Signal Analyzer System	\$9950
Opt 01 5485A Two Channel Input	N.C.
Opt 02 5487A Four Channel Input	+ \$375
Opt 03 5488A Correlation/Average Input	+ \$475
5489A Low-Pass Filter	\$425

The basic 5481A Signal Analyzer System includes the 5480S Option 01, the 2114B Digital Computer, the 2752A Teleprinter, and the 10625A Interface with complete software.

5481A Signal Analyzer System \$28,450

Complete specifications available on the 5480S Technical Data Sheet.

WAVE ANALYZER PLUG-IN

Accuracy with long sweep time

Model 3595A/3590A or 3591A



SIGNAL ANALYZERS

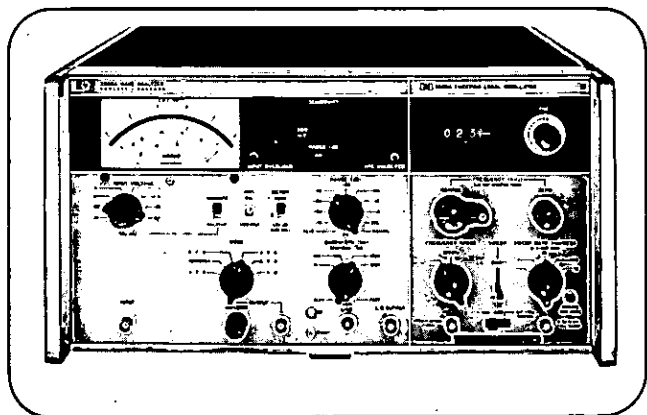

Description

Another plug-in is available for the 3590A Wave Analyzer and the 3591A Selective Voltmeter (pages 455 and 432 respectively in the 1970 General Catalog.)

The 3595A Local Sweeping Oscillator Plug-in was designed to fulfill the requirement of slow sweeping for long periods of time. Using the 2 Hz per second sweep speed the 3595A can sweep the entire audio spectrum (20 Hz to 20,000 Hz) with a 10 Hz bandwidth. At 1 Hz per second, 10 kHz can be covered in one sweep. Thus the frequency response of low frequency networks, transducers, filters etc. can be measured accurately over several decades of frequency.

The choice of bandwidths (10 Hz, 100 Hz, 1 kHz and 3.1 kHz) and sweep rates (1,2,100 Hz and 1 kHz per second) make it possible to sweep both lower and higher frequencies at the desired speed.

The dynamic range of 85 dB, the sensitivity of 3 μ volts to 3 volts and many other features of the main frames enlarge the usability of this instrument.

Baseband Monitor

A number of communication channels are frequency multiplexed to form the baseband signal shown in the plot. A 3591A can be used to monitor the output and noise levels. The plot shows the output levels which are out of adjustment. Modulation distortion products can be seen near the noise level.

The permanent recording is made daily to check intermodulation distortion products, spurious signals, noise level and signal levels. All the operator need do is put paper in the X-Y recorder and start the sweep.

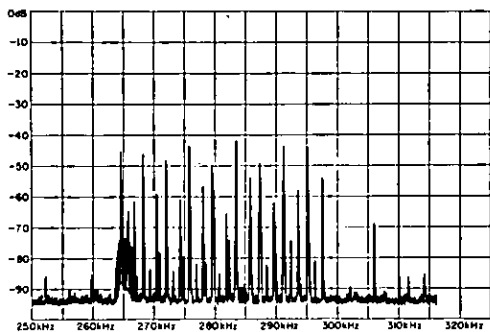

Figure 1. Baseband recording using the 3595A.

Power Line Analysis

The 3590A can be used to analyze the power line for harmonic signal content. The line voltage must be attenuated to less than 30 V so the input amplifier is not overloaded. Even with the attenuation the 3590A displays an equivalent range of 115 V to less than 11.5 mV. The accompanying plot shows the large number of harmonics present on the normal power line. To separate the 60 Hz harmonics, the 10 Hz bandwidth of the 3590A was used.

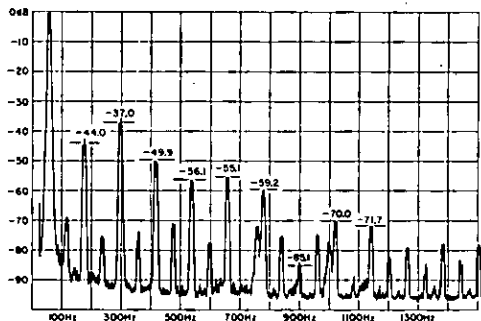

Figure 2. Power line recording using the 3595A

3595A Specifications

	Frequency Ranges	
	20 Hz to 62 kHz	200 Hz to 620 kHz
Frequency accuracy:	\pm (1% +20 Hz) of dial setting	\pm (1% +200 Hz) of dial setting
Frequency resolution:	10 Hz/minor div.	100 Hz/minor div.
Ext. frequency control:	0 to 15.5 V (250 mV/kHz \pm 5%)	0 to 15.5 V (25 mV/kHz \pm 5%)
Bandwidth specified:	10, 100, 1000, 3100 Hz	100, 1000, 3100 Hz
Linear output: (1 k Ω source resistance)	0 to -12.4V (200 mV/kHz \pm 5%)	0 to -12.4 V (20 mV/kHz 5%)
X-axis Log output:	5 V/decade \pm 5% (20 Hz - calibration point for 0 V output)	5 V/decade \pm 5% (200 Hz - calibration point for 0 V output)

Y-axis

Linear output: +5 V dc, \pm 4% full scale proportional to meter indication, 2.5 k Ω source resistance.

Log output: +1 V to +10 V dc, \pm .1 V proportional to linear dB meter indication (-90 to 0 dB, 0.1 V/dB) 1 Ω source resistance.

Sweep rates: 1 Hz/s, 2 Hz/s, 10 Hz/s, 100 Hz/s, 1000 Hz/s.

Sweep ramp linearity: \pm 2.5% of final value for first 10,000 s; will sweep for 60,000 s.

Start frequency: determined by frequency control setting.

Pen lift: contact closure during sweep, open during reset.

External L.O. input: 0.65 V \pm 0.2 V rms, 1.28 to 1.90 MHz (1.28 MHz + tuned frequency).

Dimensions: 8 in high, 4.5 in wide, 11 in deep (20 x 11 x 28 cm).

Price: HP 3595A, \$1250.

OSCILLOSCOPES



7MHz OSCILLOSCOPES

DC to 7 MHz, 5mV, Dual Trace

Models 1215 A/B, 1217 A/B

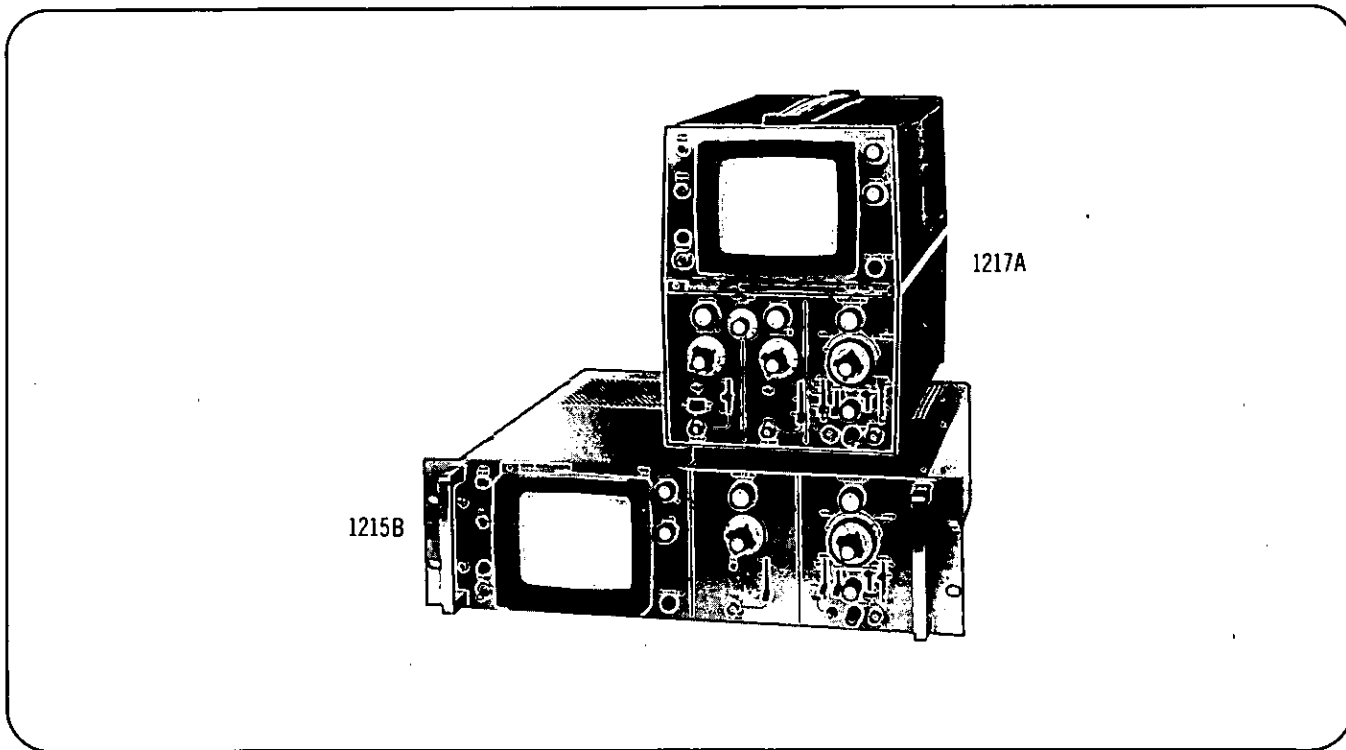

Seven MHz bandwidth coupled with 5 mV deflection factor of the single channel 1215A/B and dual channel 1217A/B provide the most versatile general purpose instrument for today's medium frequency applications. These oscilloscopes are all solid-state, portable, reliable, stable, and are ideal for a variety of applications.

- R & D laboratory design
- Production line testing
- Educational laboratories
- Scientific research
- Systems instrumentation
- Information display

The many features of these scopes give you accurate, versatile, easy-to-read, displays. The logical arrangement of controls, beam finder that locates off-screen displays, and automatic triggering make operation easy, especially important to persons in production line testing and classroom or laboratory instruction. In addition these units offer:

- **Direct-reading Sweep Magnifier.** The sweep time and magnifier controls provide a direct reading of a magnified sweep. No need to divide to determine magnified sweep time, which reduces the chance of error.

- **Internal Graticule.** The internal graticule, developed by HP, is in the same plane as the phosphor, which eliminates parallax error inherent with an external graticule CRT. A bright display with small spot size and black graticule lines gives you good contrast for easy, accurate readings.

- **Versatile, Simplified Sweep Operation.** Single, normal, and free run modes of operation are flexible enough for complex measurements, yet operation is simple and straight forward. Trigger coupling, slope, source, and level can be selected by the operator. Also, an internal low frequency trigger source switch position attenuates trigger signals above 5 kHz allowing you to synchronize the trigger on a desired low frequency

signal. In single sweep mode a reset control, allows the operator to reset the sweep from any point in a sweep.

- **DC-Coupled Z-Axis Amplifier.** The dc-coupled Z-axis amplifier permits a display with more information by using variations of intensity. In an application where the input signal duty cycle changes, the Z-axis input may be externally programmed to maintain constant intensity for any frequency.

- **Stability.** Field effect transistors at the vertical amplifier input provide low drift operation virtually free of annoying trace shifts caused by temperature changes, shock, and vibration. Long term stability also means less frequent calibration and lower periodic maintenance costs.

- **System Applications.** Rack versions (Models 1215B and 1217B) and only 5¼ inches high which saves valuable rack space and allows more instruments to be mounted in a rack for a more versatile system. Since these instruments are complete instruments, they offer the system user not only a read-out device but a convenient calibration and service tool.

Specifications

Specifications apply to single channel models 1215A/1215B and dual channel models 1217A/1217B except as noted

Vertical amplifiers

Bandwidth

DC-coupled: dc to 7 MHz.

AC-coupled: 2 Hz to 7 MHz.

Deflection factor

Ranges: from 5 mV/div to 20 V/div (12 positions) in 1,2,5 sequence.

Attenuator accuracy: ±3% with vernier in calibrated position

Vernier: continuously variable between all ranges; extends maximum deflection factor to at least 50 V/div.

Input RC: 1 megohm shunted by approx 35 pF, constant on all ranges.

Input: single-ended on all ranges.

Input coupling: selectable AC, DC, or OFF. Off position disconnects input and ground amplifier input.

Remaining Vertical Amplifier Specifications Apply to Dual Channel Models Only.

Modes of operations: channel A; channel B; channels A and B (either chop or alternate triggered by channel A); channels A + B (triggered by channels A + B). Chop frequency is approx 100 kHz.

Differential input: channel A may be inverted for differential operations. Bandwidth and deflection factors remain unchanged.

Common mode.

Frequency: dc to 100 kHz.

Rejection ratio: 30 dB on 5, 10, and 20 mV/div ranges and 20 dB on all other ranges.

Maximum signal: 30 div.

Internal trigger source: on channel A signal for A, Chop and Alternate displays; on channel B signal for B display; on channels A + B signals for channel A + B display.

Time base

Sweep

Ranges: 1 μ s/div to 5 s/div (21 positions) in 1,2,5 sequence. $\pm 3\%$ accuracy with vernier in calibrated position.

Vernier: continuously variable between ranges, extends slowest to at least 12.5 s/div.

Magnifier: direct reading X10 magnifier expands fastest sweep to at least 100 ns/div with $\pm 5\%$ accuracy.

Automatic triggering

Baseline displayed in absence of input signal.

Internal: 50 Hz to 2 MHz for most vertical signals causing a minimum of 0.5 div deflection, increasing to 1 div at 7 MHz.

Triggering on line frequency also selectable.

External: 50 Hz to 2 MHz for most signals at least 0.2V pk-pk, increasing to 0.5 V pk-pk at 7 MHz.

Trigger slope: selectable, positive or negative slope on internal or external signals.

Amplitude selection triggering

Internal: dc to 7 MHz on signals causing 0.5 div or more vertical deflection.

External: dc to 7 MHz on signals at least 0.2 V pk-pk. Input impedance is 1 megohm shunted by approx 20 pF.

Trigger level and slope: internal, at any point on vertical waveform displayed; external, continuously variable from +100 V to -100 V on either slope of external signal up to 1 MHz.

Trigger coupling: dc or ac for external line or internal triggering. Lower ac cutoff, 1.6 Hz in external, 16 Hz in internal.

Internal low frequency triggering: internal trigger signal is attenuated at approx 6 dB per octave for frequencies above 5 kHz.

Single sweep: selectable with front panel control with armed indicator light.

Free run: selectable with front panel controls.

Maximum input: ± 350 V (dc + peak ac).

Horizontal amplifier

Bandwidth

DC-coupled: dc to 300 kHz.

AC-coupled: 1.6 Hz to 300 kHz.

Deflection factor

Ranges: 0.1 V/div, 0.2 V/div, 0.5 V/div, and 1 V/div.

Vernier: continuously variable between ranges, extends maximum deflection factor to at least 2.5 V/div.

Maximum input: ± 350 V (dc + peak ac).

Input: single-ended on all ranges.

Cathode-ray tube and controls

Type: mono-accelerator, 3 kV accelerating potential with etched safety glass faceplate; P31 phosphor standard (refer to options for other phosphors).

Graticule: 8 X 10 div internal graticule: 1 div = 1 cm. 0.2 subdivision markings on horizontal and vertical major axes.

Beam finder: returns trace to CRT screen regardless of setting of horizontal, vertical, or intensity controls.

Intensity modulation: +2 V signal blanks trace of normal intensity; +8 V signal blanks any intensity trace. DC-coupled rear panel input; amplifier rise time, approx 200 ns; input R, 5 k ohms.

Calibrator

Type: line frequency square wave.

Output: 1 V $\pm 1.5\%$.

NOTE:
DIMENSIONS IN INCHES AND
(MILLIMETERS)

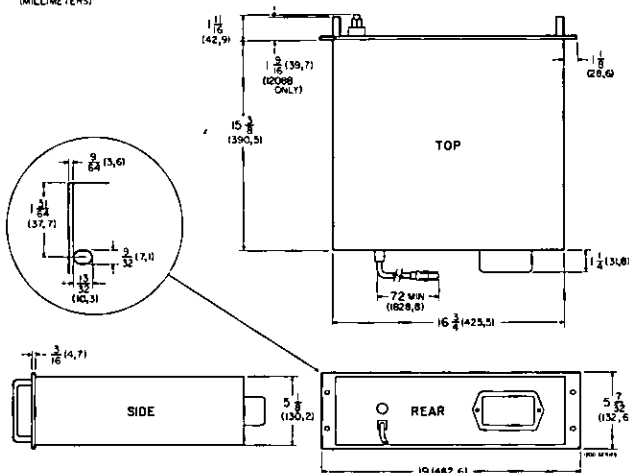

General

Dimensions

Cabinet (Models 1215A and 1217A): 8 3/8 in. wide x 11 3/8 in. high x 18 1/8 in. deep (211,1 x 298,5 x 474,7 mm).

Rack (Models 1215B and 1217B): refer to outline drawing.

Power: 115 or 230 V $\pm 10\%$; 48 to 440 Hz; approx 70 watts for Models 1215A/B and 75 watts for models 1217A/B at 60 Hz and 115 V.

Weight

Model 1215A (cabinet): net 23 1/4 lb. (10,7 kg); shipping, 33 1/4 lb. (15,2 kg).

Model 1215B (Rack): net, 22 lb. (10 kg); shipping, 35 1/4 lb. (16,1 kg).

Model 1217A (cabinet): net 24 1/4 lb. (11,1 kg); shipping, 34 1/4 lb. (15,6 kg).

Model 1217B (rack): net 23 lb. (10,4 kg); shipping 35 lb. (15,9 kg).

Price: Model 1215A or B, \$950. Model 1217A or B, \$1175.

Options (order by option number)

001: factory wired for 230 V operation, no charge

002: P2 phosphor in lieu of P31, no charge.

006: (rack models 1215B and 1217B); rear terminals wired in parallel with front panel vertical and horizontal input terminals. Increases vertical input shunt capacitance to approx 85 pF and horizontal input shunt capacitance to approx 75 pF. Add \$35 for 1215B and \$55 for 1217B.

007: P7 phosphor in lieu of P31, no charge

011: P11 phosphor in lieu of P31, no charge. Note: due to burn sensitivity of P11 phosphor, the beam finder intensification function is removed from option 011 oscilloscopes.

631: non-internal graticule CRT with P31 phosphor, no charge.



SYSTEM DISPLAY

Solid State, X-Y Display, Storage
Models 1331A, 1331C, 1330A

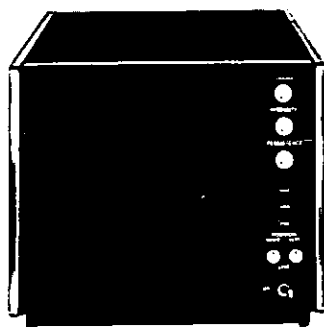

1331A

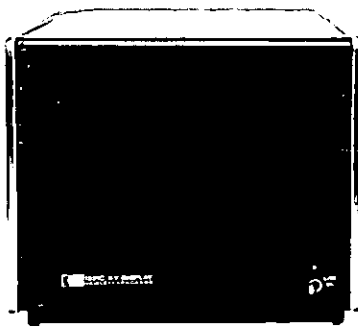

1331C

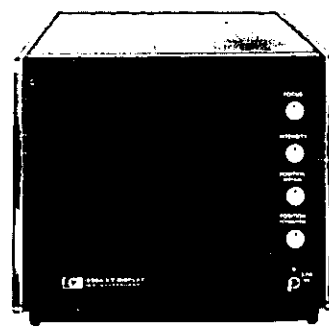

1330A

Description

Models 1331A and 1331C X-Y Displays are compact half-rack storage monitors with X, Y, and Z bandwidths of 1 MHz. These displays fill the same basic applications of Model 1330A with the added advantage of the HP mesh type storage tube which eliminates the need for a computer refreshed display.

Model 1331A has front panel controls for convenient manual operation of X-Y position and storage or variable persistence controls where spot deflection and dot writing speed varies. Model 1331C has rear panel operating controls and programming connector for remote programming in computer or graphic display systems.

Both instruments write and store shades of gray, which adds a third dimension to the display. Full spot blanking is obtained with -1 V, and +1 V turns beam full on with in-between voltages providing shades of gray.

Model 1331C remote programming functions are DTL and TTL compatible which allows the display to interface directly with most systems. If desired, transfer from WRITE to STORE modes and ERASE may be accomplished by contact closure to ground at the remote program plug. Transition from STORE to WRITE and back to STORE, including dot writing time, can be made in approximately 7 μ s. This effectively increases the time you can "store" by allowing the display to take advantage of the inherent longer storage time offered by the store mode between writing commands.

The Hewlett-Packard developed mesh type storage tube in these displays eliminates the need for memory devices to constantly refresh the display. Other advantages of this type

tube, which makes it ideal for system applications are: bright stored displays which allows viewing in high ambient light conditions; long life, comparable to standard CRT tube life, with storage characteristics and brightness remaining essentially constant during the tube's life.

Specifications, 1331A/C

(Unless otherwise noted, specifications apply to both models.)

Vertical and horizontal amplifiers

Bandwidth: dc to 1 MHz (3 dB down at 1 MHz).

Phase shift: $< 1^\circ$ to 0.5 MHz.

Setting time: signal settles to within 1 spot diameter of final value in $< 1 \mu$ s for any on screen movement.

Deflection factor

Vertical: 1 V for 8 div deflection. Internally adjustable from 0.09 V/div to 0.14 V/div.

Horizontal: 1 V for 10 div deflection. Internally adjustable from 0.09 V/div to 0.14 V/div.

Common mode rejection ratio: 40 dB to 10 kHz for differential input of 3 V maximum between outer and inner coaxial input leads.

Maximum input: ± 50 V (dc + peak ac).

Input RC

Single-Ended: 100 k ohms shunted by approx 80 pF to ground.

Differential: 200 k ohms shunted by approx 80 pF.

Recommended source impedance: ≤ 20 k ohms between center conductor and shield and ≤ 1 k ohm from shield to ground.

Z Axis amplifier

Input RC

Single-Ended: 100 k ohms shunted by approx 60 pF to ground.

Differential: 200 k ohms shunted by approx 60 pF.

Input: -1 V blanks spot of any intensity. +1V turns beam full on.

Maximum input: ± 10 V (dc + peak ac).

Recommended source impedance: ≤ 20 k ohms between center conductor and shield and ≤ 1 k ohm from shield to ground.

Cathode-ray tube and controls

Type: post-accelerator storage tube 10.5 kV accelerating potential, aluminized P31 phosphor.

Graticule: 8 x 10 div internal graticule. 1 Div = 0.95 cm. Subdivisions of 0.2 div marked on major axis.

Persistence and storage characteristics
(Referenced to a centered 7 x 9 div area.)

Models 1331A and 1331C Control and Input Physical Location

Model	Write, Store, and Erase	Variable Persistence	Intensity and Focus	X and Y Position	X, Y, and Z Inputs
1331A	Front Panel Switches	Front Panel Control	Front Panel Controls	Front Panel Controls	Rear Panel
1331C	Rear Panel Programming	*Fixed at maximum	Rear Panel Adjustment	Rear Panel Adjustment	Rear Panel

*Variable or internally adjustable persistence available on special order.

Writing speed: > 20 div/ms.

Dot writing time: < 4 μ s

Display linearity

Horizontal: < 5% difference between any two div.

Vertical: < 5% difference between any two div.

Information storage rate: 200 thousand dots per second.

Brightness: > 100 foot lamberts (in write mode).

Storage time

Write mode: 1 minute minimum.

Store mode: 15 minutes minimum.

Variable persistence (Model 1331A): variable from 0.2 s to 1 min.

Erase time: < 1 s

Beam Finder: returns beam to screen regardless of setting of X and Y position controls. Rear panel switch.

NOTE:
DIMENSIONS IN INCHES AND (MILLIMETERS)

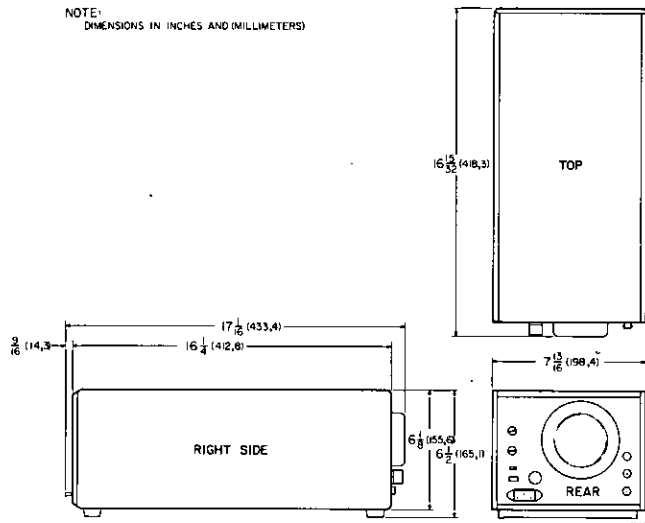

Model 1331C programmable functions

(Write, Store, Erase)

All program functions are TTL/DTL compatible.

Input levels: high state is +2.0 V or greater, low state is +0.8 V or less for all program plug inputs. For high state = 2.4 V, $I_{sink} = 0.4$ mA max. For low state = 0.4 V, I_{source} is < 1 mA.

Remote erase: low state for 10 μ s minimum initiates erase cycle.

Remote mode transfer: high state is store mode, low state is write mode.

Dot writing using mode transfer: dot may be written by transferring to write mode for 7 μ s per dot. No degradation of storage time occurs.

Erase verify: indicates end of erase cycle. Output voltage is high approx 125 ms after start of erase cycle. Voltage drops to low state and remains low to the end of erase cycle. High state is 2.4 V minimum with $I_{source} = 80$ μ A maximum. Low state 0.4 V maximum with $I_{sink} = 3.2$ mA maximum.

General

Input connectors

X, Y, and Z inputs: rear panel BNC.

Model 1331C program connector: Cannon Model 15 P.

Power: 115 or 230 V \pm 10%, 48 to 440 Hz, approx 60 watts at 60 Hz and 115 V.

Weight: net, 19 1/2 lb (8,85 kg); shipping 25 lb (11,34 kg).

Dimensions: refer to outline drawing.

Price: Model 1331A or 1331C, \$1575; OEM discounts are available.

Option: (order by Option Number)

016: provides direct connection of a Model 1331C to an HP computer through a 12555A interface kit.

Price, add \$150.

1330 and 1331 Accessories

Rack adapter: allows two X-Y displays to be mounted side-by-side in a standard 19-inch rack, HP Part No. 5060-0797.

Price: \$25.

Filler panel: covers half of the Rack Adapter when only one display is mounted in the Rack Adapter, HP Part No. 5060-0794.

Price: \$7.

Camera Adapter: Model 10366A camera adapter allows a HP Model 195A, 197A, or 198A camera to be mounted on a display.

Price: \$15.

Description

Model 1330A X-Y Display is a compact, half-rack, solid-state instrument for displaying digital or analog computer-processed data or real-time information. The 1 MHz X and Y bandwidths and 5 MHz Z-axis bandwidth makes this instrument an extremely useful readout device in applications such as: graphic and alphanumeric, nuclear spectrometer, semiconductor curve tracer, raster, and amplitude versus time displays; swept frequency, frequency ratio, and phase shift measurements. Also, the X, Y and Z differential amplifier inputs are isolated from ground to provide noise rejection which reduces noise signals common to the inner and outer conductor of interconnecting cables.

Specifications; 1330A

Vertical and horizontal amplifiers

Bandwidth: dc to 1 MHz (3 dB down at 1 MHz).

Phase shift: < 1° to 500 kHz; 2° to 1 MHz.

Setting time: signal settles to within 1 spot diameter of final value in < 1.2 μ s for any on screen movement.

Deflection Factor

Vertical: 1 V for 8 div deflection. Internally adjustable from 0.09 V/div to 0.14 V/div.

Horizontal: 1 V for 10 div deflection. Internally adjustable from 0.09 V/div to 0.14 V/div.

Input: differential between center conductor and shield. Shield may be grounded with internal connection.

Common mode rejection ratio: 40 dB to 10 kHz for differential inputs of 3 V maximum between outer and inner coaxial input leads.

Maximum input: \pm 50 V (dc + peak ac).

Input RC

Single ended: 100 k ohms shunted by approx 80 pF to ground.

Differential: 200 k ohms shunted by approx 80 pF.

Recommended source impedance: \leq 20 k ohms between center conductor and shield and \leq 1 k ohm from shield to ground.

Z axis amplifier

Bandwidth: dc to 5 MHz; rise time, approx 70 ns.

Input RC

Single-ended: 10 k ohms shunted by approx 60 pF to ground.

Differential: 20 k ohms shunted by approx 60 pF.

Input: -1 V blanks spot of any intensity; +1 V turns beam full on.

Maximum input: \pm 10 V (dc + peak ac).

Cathode-ray tube and controls.

Type: mono-accelerator, 3k V accelerating potential; P31 phosphor standard (refer to options for other phosphors).

Graticule: 8 x 10 div internal graticule. 1 div = 1 cm.

Subdivision markings of 0.2 div on major horizontal and vertical axis.

Display linearity

Horizontal: < 5% difference between any two div.

Vertical: < 5% difference between any two div.

Beam Finder: returns beam to screen regardless of setting of horizontal, vertical, or intensity controls. Rear panel switch.

General

X, Y, and Z input connectors: rear panel BNC.

Weight: net, 19 1/2 lb. (8,85 kg); shipping, 25 lb. (11,34 kg).

Power: 115 or 230 V \pm 10%, 48 to 440 Hz, approx 60 watts at 60 Hz and 115 V.

Dimensions: refer to 1331A outline drawing.

Price: Model 1330A, \$800. OEM discounts are available.

Options: (order by option number)

002: P2 phosphor in lieu of P31, no charge.

007: P7 phosphor in lieu of P31, no charge.

011: P11 phosphor in lieu of P31, no charge. Note: due to burn sensitivity of P11 phosphor, the Beam Finder intensification function is removed from option 011 displays.

631: non-internal graticule CRT with P31 phosphor, no charge.



600 kHz, X-Y DISPLAY, STORAGE

Storage/Variable persistence
Model 1208B, Option H12

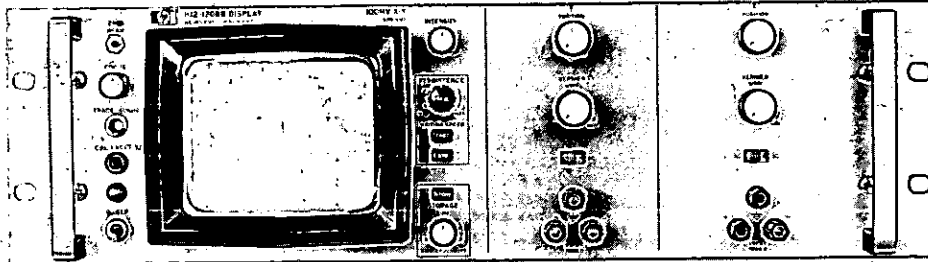

1208B, Opt H12

Description

Model 1208B Option H12 X-Y Display is a 19-inch rack, solid-state storage instrument with front panel controls and inputs. This display has the same basic applications of the Model 1330A and characteristics of Model 1331A but is designed for applications that only require 600 kHz bandwidths and where vertical rack space is limited to 5¼".

Deflection factor of each amplifier is continuously variable from <math>< 100 \text{ mV/div}</math> to $> 1 \text{ V/div}$ with a common mode rejection ratio of 40dB (100:1) to 10 kHz. The identical amplifiers provide <math>< 1^\circ</math> phase shift up to 500 kHz with equal deflection factors <math>< 200 \text{ mV/div}</math> and to 100 kHz > 200 mV/div.

Specifications

Vertical and Horizontal amplifiers

Bandwidth

DC-coupled: dc to 600 kHz.

AC-coupled: 20 Hz to 600 kHz.

Deflection factor: continuously variable from <math>< 100 \text{ mV/div}</math> to $> 1 \text{ V/div}$.

Input: differential or single ended.

Input coupling: front panel selection of ac or dc.

Input RC: 100 k ohms shunted by approx 70 pF.

Maximum input: $\pm 200 \text{ V}$ (dc + peak ac).

Common mode

Rejection ratio: 40 dB (100:1) with dc input coupling.

Signal maximum: up to $\pm 4 \text{ V}$ (dc + peak ac).

Frequency: dc to 10 kHz.

Phase shift

Same X and Y deflection factor (with + inputs): <math>< 1^\circ</math> to 500 kHz for deflection factors <math>< 200 \text{ mV/div}</math>, <math>< 1^\circ</math> to 100 kHz for deflection factors > 200 mV/div.

Different X and Y deflection factors (with + inputs; - inputs; or differential): <math>< 3^\circ</math> to 100 kHz.

Cathode-ray tube and controls

Type: post-accelerator, variable persistence storage tube; 10.5 kV accelerating potential; aluminized P31 phosphor.

Graticule: 8 x 10 division internal graticule; 0.2-div. subdivision markings on horizontal and vertical major axes. 1 div = 0.95 cm.

Front panel adjustment aligns trace with graticule.

Beam Finder: returns trace to CRT screen regardless of setting of horizontal or vertical controls.

Intensity modulation: +2-volt signal blanks trace of normal intensity; +8 V signal blanks any intensity trace. DC-coupled rear panel input. Input R, 5 k ohms.

Note: Persistence and storage characteristics are referenced to a centered 7 x 9 div area.

Persistence: continuously variable from 200 ms to > 1 minute in STD modes, from 200 ms to 15 s in FAST mode.

Storage writing speed: STD mode, $\geq 20 \text{ cm/ms}$; FAST mode, $\geq 0.5 \text{ cm}/\mu\text{s}$.

Brightness: ≥ 100 foot-lamberts (in write mode).

Storage time

STD writing speed: more than 2 hours at reduced brightness (typically 4 hours). Traces may be viewed at maximum brightness for more than one minute.

Fast writing speed: more than 15 minutes at reduced brightness (typically 30 minutes) or stored at maximum brightness for more than 15 seconds.

Erase: manual pushbutton or remote erase through rear panel banana jack, erasure takes approx 1 s.

Calibrator

Type: line frequency square wave.

Output: $1 \text{ V} \pm 1.5\%$, front panel banana plug.

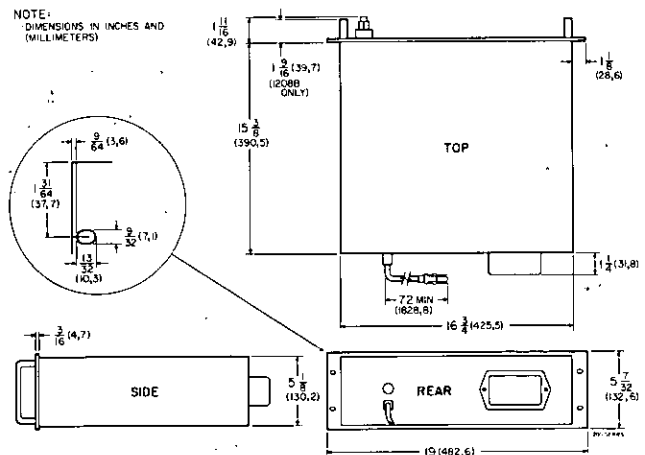

General

Weight: net, 25½ lb (11.6 kg); shipping 38 lb (17.2 kg).

Power: 115 or 230 V $\pm 10\%$, 48 to 440 Hz, approx 40 watts at 60 Hz and 115 V.

Dimensions: refer to outline drawing.

Options: (order by Option Number)

001: factory wired for 230 V operation, no charge.

006: rear input terminals wired in parallel with front panel input terminals. Increases input shunt capacitance to approx 120 pF. Add \$55.

Specials: special versions are available with deflection factor ranges starting at 100 $\mu\text{V/div}$ or 5 mV/div. Contact your HP Field Engineer for more information.

Price: Model 1208B Opt. H12, \$1450.

OSCILLOSCOPE MAINFRAME

Large screen, 100 MHz
Model 182A



OSCILLOSCOPES

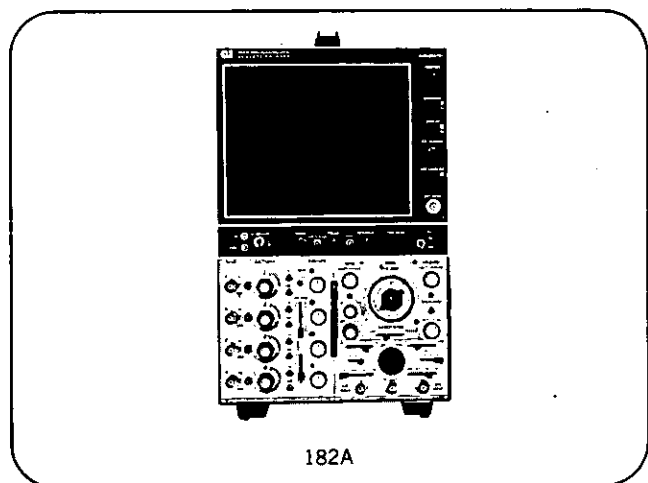

Description

Model 182A plug-in oscilloscope mainframe adds large screen, 100 MHz bandwidth to the proven 180 oscilloscope system. The parallax free, internal graticule is 8 X 10 divisions with each division equal to 1.34 cm which makes it easier to view displays from a distance. This larger CRT area, 80% larger than 8 X 10 cm displays, also improves viewing of displays such as four-channel, differential/dc-offset, and time domain reflectometer measurement.

The Model 182A accepts all 1800 series plug-ins designed for 180 and 181 mainframes, including 50 or 100 MHz dual-channel vertical amplifiers, a 50 MHz four-channel amplifier, a differential/dc-offset amplifier, standard or delayed sweep time bases, and a time domain reflectometer.

Another feature of this mainframe is its design for maintainability. Plug-in circuit modules that connect to a printed circuit mother board almost eliminate internal cabling, which increases reliability and makes it easier and quicker to get an instrument back into service. For example; the horizontal amplifier is on a plug-in circuit board that includes a section of front panel with knobs and switches mounted on it. This allows a complete board to be quickly installed, which keeps instrument down-time to a minimum.

Specifications,

Cathode-ray tube and controls

Type: post-accelerator, 19 kV accelerating potential; aluminized P31 phosphor standard (refer to options for other phosphors).

Graticule: 8 x 10 div internal graticule. 1 div = 1.34 cm. 0.2 subdivision markings on horizontal and vertical major axes. Front panel adjustment aligns trace with graticule. Scale control adjusts graticule illumination.

Beam finder: returns trace to CRT screen regardless of setting of horizontal, vertical, or intensity controls.

Intensity modulation: approx +2 V, ≥ 50 ns pulse width ≤ 10 MHz CW) blanks trace of normal intensity. Input R, approx 5 k ohms. Maximum input voltage, ± 20 Vdc.

Calibrator

Type: approx 1 kHz square wave, < 3 ns rise time.

Voltage: two outputs, 250 mV pk-pk and 10 V pk-pk; accuracy, $\pm 1\%$.

Horizontal amplifier

External Input

Bandwidth

DC-coupled: dc to 5 MHz.

AC-coupled: 5 Hz to 5 MHz.

Deflection factor: X1, 1 V/div; X 10, 100 mV/div. Vernier pro-

vides continuous adjustment between ranges. Accuracy, $\pm 5\%$.

Dynamic range: ± 20 V.

Maximum input: 300 Vdc.

Input RC: 1 megohm shunted by approx 30 pF.

Internal Sweep

Sweep magnifier: X10; accuracy $\pm 5\%$

Outputs: four emitter follower outputs on rear for main and delayed gates, main and delayed sweeps or vertical and horizontal outputs when used with sampling plug-ins; maximum current available, ± 3 mA; outputs will drive impedances ≥ 1000 ohms without distortion.

General

Weight: (without plug-ins) net, 26½ lb. (12,02 kg); shipping 38½ lb. (17,46 kg).

Dimensions: refer to outline drawing.

Environment: mainframe operates within specifications over the following ranges.

Temperature: 0°C to +55°C.

Humidity: up to 95% relative humidity at 40°C.

Altitude: up to 15,000 ft.

Vibration: vibrated in three planes for 15 minutes each with 0.010 inch excursion, 10 to 55 Hz.

Power: 115 or 230 V $\pm 10\%$, 48 to 440 Hz, < 200 VA with plug-ins, convection cooled.

Accessories furnished: metallic mesh contrast filter; 7½ ft. power cord.

Price: (without plug-ins) Model 182A, \$1100.

Options (order by option number)

002: aluminized P2 phosphor in lieu of P31, no charge.

007: aluminized P7 phosphor in lieu of P31, no charge.

011: aluminized P11 phosphor in lieu of P31, no charge.

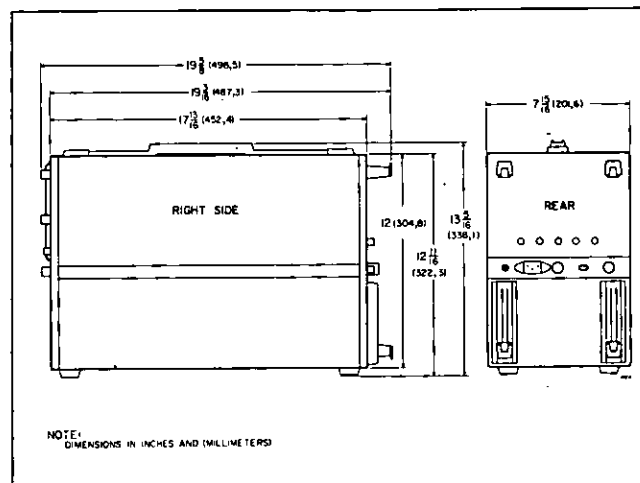

Optional accessories

Dust cover

Model 10172A Dust Cover provides protection for Model 182A during transportation or storage. The cover top is slotted for access to the oscilloscope carrying handle and has a pocket on the side for an operating manual and/or probes and accessories.

Camera adapter

Model 10367A Camera Adapter adapts the general purpose Model 197A and high speed Model 195A cameras to the large screen Model 182A Oscilloscope:

Service cable

Model 10133A Service Cable allows the Model 182A low voltage power supply module to be serviced outside the mainframe.



TRANSIENT DISPLAY

8 cm/ns Writing Speed

Models 183C/D, 1831A/B, 1841A

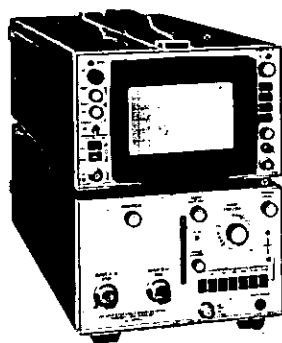

183C

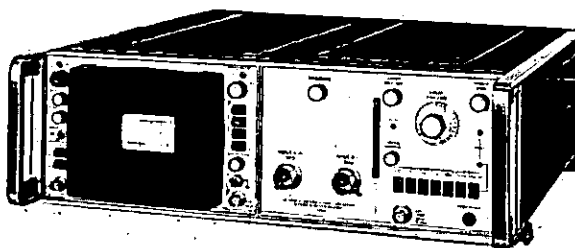

183D

Description

Models 183C and 183D Oscilloscope mainframes provide a fast writing speed of 8 cm/ns with ASA 10,000 film, P31 phosphor, $f/1.3$ lens, 1:0.5 object-to-image ratio, and pulsed flood-gun fogging. This fast writing speed is achieved by compressing both the beam and scan, which reduces deflection to a 3 x 5 cm area and the beam to less than half the normal spot size. The fast writing speed is illustrated in the single-shot photograph of a 1 GHz sine wave and a 600 ps rise time step.

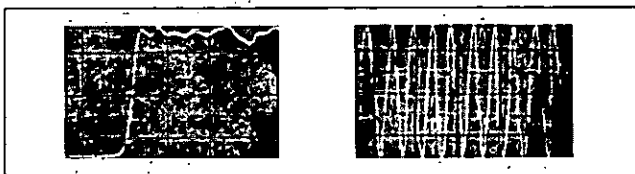

To make the fast writing speed useful, two direct access plug-ins are available that match a 50 ohm input to the 330 ohm balanced line CRT deflection structure. Model 1831A provides balanced or single-ended inputs with a frequency response greater than 600 MHz and a deflection factor of ≈ 6 V/div. Model 1831B is a single-ended plug-in that includes a delay line, which allows the sweep to be triggered by the displayed signal. Frequency response of the Model 1831B is greater than 500 MHz with a deflection factor of ≈ 6 V/div.

Normal 6 x 10 cm scan, with a writing speed of 4 cm/ns, can be restored by moving the CRT post accelerator cable to another tap on the high-voltage supply. This allows use of full scan when any of the plug-ins designed for the HP 180/183 Oscilloscope system are used in these mainframes. This allows the Model 183C/D mainframes to be used as general-purpose oscilloscopes or for displaying high-speed, single-shot transients.

Specifications, Models 183C and D

Cathode-ray tube and controls

Type: Post-accelerator 20 kV accelerating potential; aluminized P31 phosphor (refer to options for other phosphors); safety glass face plate.

Writing speed: (with 10,000 ASA film, P31 phosphor, $f/1.3$ lens, 1:0.5 object-to-image ratio and pulsed flood gun fogging) normal scan, > 4 cm/ns; reduced scan > 8 cm/ns.

Graticule: normal scan, 6 x 10 division internal graticule. 0.2 subdivisions on major horizontal and vertical axes, 1 div = 1 cm; reduced scan, 6 x 10 division internal graticule (1 div = 0.5 cm) superimposed in center of normal scan graticule.

Flood gun: illuminates CRT phosphor. Normal or pulsed mode of operation selected with rear panel switch. Scale control adjusts graticule illumination and pulsed mode which increases photographic writing speed.

Beam Finder: returns trace to CRT screen regardless of setting of horizontal or vertical controls.

Intensity modulation: approx +2 V, 50 ns pulse width (≤ 15 MHz CW) blanks trace of normal intensity. Input R, 4700 ohms. +15 V blanks trace of any intensity.

Calibrator

Pulse timing: mode 1, 2 kHz rep-rate (0.5 ms period); pulse width 50 μ s; mode 2, 1 MHz rep-rate (1 μ s period); pulse width, 100 ns; accuracy (mode 1 and mode 2), $\pm 0.5\%$, 10°C to 40°C; $\pm 1.0\%$ 0°C to 55°C.

Amplitude: selectable 50 mV or 500 mV, $\pm 1\%$ into 50 $\pm 0.5\%$ ohms.

Source R: 50 ohms, nominal.

Pulse shape (measured with 1 GHz bandwidth sampler): rise time (neg), < 1 ns; overshoot and ringing, $\pm 3\%$ max; flatness, $\pm 0.5\%$ after 5 ns with pulse top and base line perturbations averaged.

External calibrator input: calibrator shaping network shapes an external negative input that exceeds -0.5 V peak.

Rep-rate extends to > 10 MHz. Input R, approx 10 k ohms.

G, Rear panel input selected with rear panel switch and front panel light indicates when switched to external position.

Horizontal amplifier

Bandwidth: dc to 8 MHz, dc-coupled; 2 Hz to 8 MHz, ac-coupled.

Deflection factor: 1.0 V/div in X1, 100 mV/div in X10; $\pm 3\%$ with vernier in Cal position. Vernier provides continuous adjustment between ranges and extends deflection factor to at least 10 V/div. Dynamic range, ± 20 V.

Input RC: approx 1 megohm shunted by approx 20 pF.

Maximum input: 350 V (dc + peak ac).

Magnifier (Ext Horizontal input): X1 and X10, $\pm 5\%$.

Sweep magnifier: X10; magnified sweep accuracy, $\pm 5\%$ (with 3% accuracy time base plug-in).

Outputs: two rear panel emitter follower outputs for main or delayed gates or vertical or horizontal outputs when used with sampling plug-ins. Output amplitude is approx 0.75 V with 1840A time base plug-in. Will drive impedances ≥ 1000 ohms without distortion.

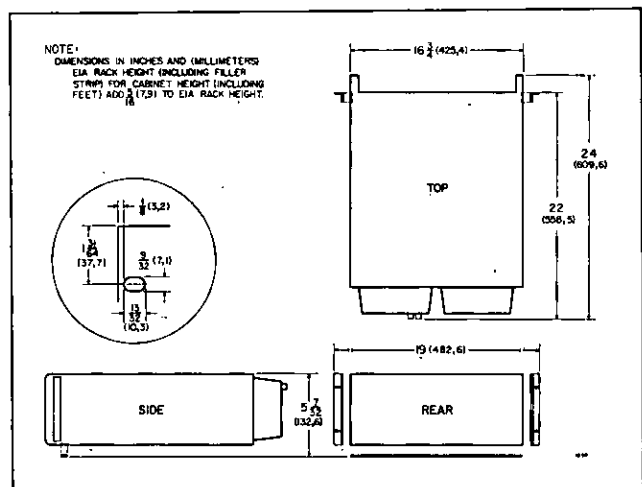

General

Weight (without plug-ins)

Model 183C (cabinet): net, 33 lb (150 kg); ship, 46 lb (20.9 kg).

Model 183D (rack): net, 35 lb (15.9 kg); ship, 48 lb (21.8 kg).

Environment: (Mainframe operates within specifications over the following ranges.) temperature, 0°C to 55°C; humidity, up to 95% relative humidity to 40°C; altitude, up to 15,000 ft; vibration, vibrated in three planes for 15 minutes each with 0.010 inch excursion, 10 to 55 Hz.

Power: 115 or 230 V $\pm 10\%$, 48 to 440 Hz, approx 115 watts with 1830A and 1840A plug-ins at 115 V and 60 Hz. Maximum mainframe power at normal line, 155 watts.

Dimensions: cabinet (Model 183C), 7-7/8" wide, 11-3/8" high, 22-3/4" deep behind front panel (200 x 289 x 578mm); rack (Model 183D), see outline drawing.

Accessories furnished: Model 10179A mesh contrast filter rack mounting hardware and two probe holders (HP Part No. 5050-0464) are also supplied with the 183D.

Price (mainframe less plug-ins): Model 183C (cabinet), \$2500; Model 183D (rack), \$2600.

Options (order by option number)

011: P11 aluminized phosphor in lieu of P31, no charge.

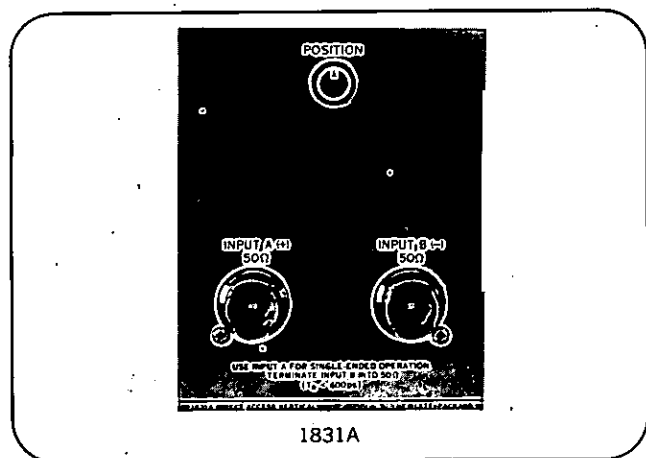

Specifications, Models 1831A and 1831B

Vertical

Bandwidth: < 20 kHz to > 600 MHz (1831A), > 500 MHz (1831B).

Rise time: < 600 ps (1831A), < 700 ps (1831B).

Pulse response: < 5% overshoot; < $\pm 5\%$ perturbations with 350 ps rise time step input from a 50 ohm source; < 6% tilt for a 1 μ s wide pulse at 25°C and < 10% tilt from 0°C to 55°C.

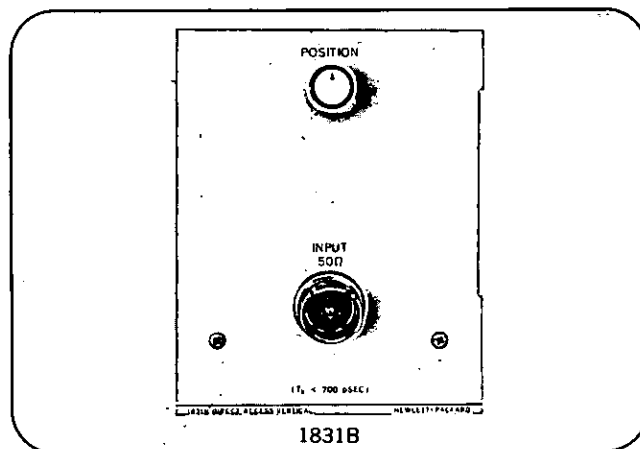

Deflection factor: 5.75 V/div, $\pm 10\%$.

Input characteristics

Input R: 50 ohms, single-ended or differential (1831A); single-ended (1831B).

Maximum dc input: ± 100 Vdc.

Maximum ac input: 2.0 watts, 4 div pk-pk CW.

VSWR: < 1.3 to 750 MHz.

Input reflections: < $\pm 10\%$, measured with 150 ps TDR.

Maximum transient input: refer to graph.

Internal triggering (1831B): stable to 500 MHz with signals producing 1/2 div or more vertical deflection.

Maximum Transient Input Graph

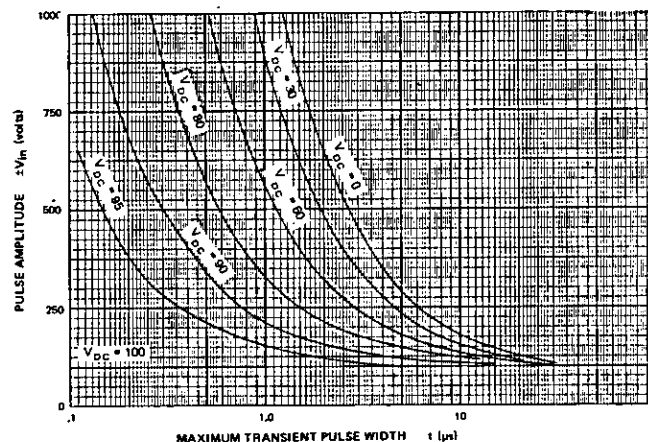

Where: V_{dc} is the dc value of input signal t (μ s) is the maximum allowable pulse width.

Example: $V_{dc} = 30$ V, $V_{in} = 750$ V pulse, then $t = 1.2$ μ s (reading from $V_{dc} = 30$ curve); maximum pulse width is 1.2 μ s.

General

Weight: 1831A net, 2 lb (0.91 kg); shipping, 5 lb (2.27 kg). 1831B net, 4 lb (1.81 kg); shipping, 7 lb (3.18 kg).

Environment: (Plug-in operates within specification over the following ranges.) temperature, 0°C to 55°C; humidity, up to 95% relative humidity to 40°C; altitude, up to 15,000 ft; Vibration, vibrated in three planes for 15 minutes each with 0.010 inch excursion, 10 to 55 Hz.

Accessories furnished: one 50 ohm load, HP Part No. 0950-0090 (Model 1831A); two mainframe termination resistors, HP Part No. 01831-61501.

Price: Model 1831A, \$375. Model 1831B, \$425.

Options:

001: 100 ohm input

Specifications for model 1831A Option 001 are the same as Model 1831A except as follows:

Bandwidth: 10 kHz to 600 MHz.

Deflection factor: 5.0 V/div, $\pm 10\%$.

Input R: 100 ohms, single-ended or differential.

External input: provides remote vertical positioning of trace over a 12 div range. Connector type, Cannon MS 3102A-14S-2P

Price: Model 1831A Option 001, \$425.

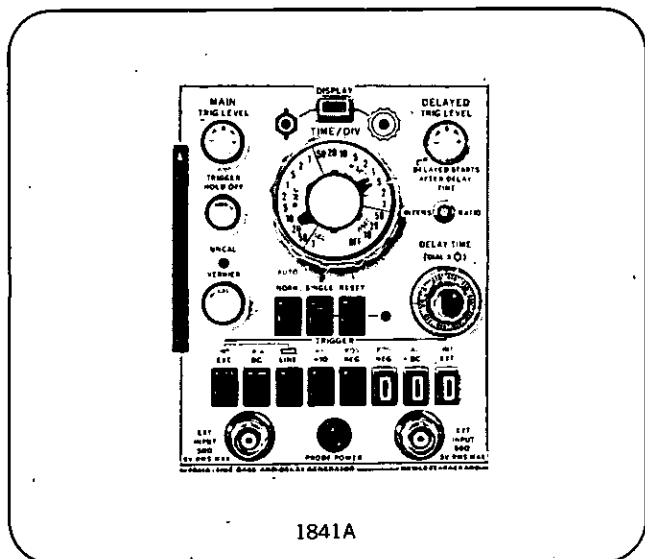

Description

Model 1841A is a new time base and delay generator for the 183 oscilloscope system. The high expansions available with the 1841A coupled with the bright cathode-ray tube in the 183 allow expanded delayed sweep measurements while maintaining adequate brightness to see the display. These wide magnification ratios are particularly useful in digital work. The 1841A features a 10 ns/div sweep speed expandable (with mainframe magnifier) to 1 ns/div. Triggering sensitivity is ≥ 20 mV to greater than 250 MHz on 20 mV of signal increasing to greater than 500 MHz on 50 mV and one knob triggering makes the 1841A extremely easy to use.

Specifications

Main time base

Sweep

Ranges: from 10 ns/div to 0.1 s/div (22 positions) in 1,2,5 sequence. $\pm 3\%$ accuracy with vernier in calibrated position.

Vernier: continuously variable between all ranges, extends slowest sweep to at least 0.25 s/div.

Magnifier (on mainframe): extends fastest sweep to 1 ns/div, $\pm 5\%$.

Sweep mode

Normal: sweep is triggered by an internal, external, or power-line signal.

Automatic: bright baseline displayed in absence of a trigger signal.

Single: sweep occurs once with same triggering as normal; reset pushbutton with armed indicator light. Rear panel input (on mainframe) provides remote arming capability.

Triggering

Internal: dc* to > 250 Mz with 1830A plug-in and signals producing 1.0 div or more vertical deflection. + 10 internal increases dynamic range by 10 allowing better noise rejection from vertical amplifier trigger signals.

External: dc* to > 250 MHz with signals of 20 mV pk-pk or more, increasing to 500 MHz on signals of 50 mV pk-pk or more. Input R, 50 ohms.

* (Automatic triggering is same as normal except low frequency limit is 5 Hz.)

Line: power line frequency trigger signal.

Level and slope: internal, at any point on the displayed vertical wave form; external, continuously variable from +100 mV to -100 mV on either slope of trigger signal; from +1V to -1V in +10 setting.

Trace intensification: used to set up delayed time base. Intensifies that part of main time base to be expanded to full screen on delayed time base. Moving delayed sweep switch from off position activates intensified mode. Front panel adjustment sets relative intensity of brightened segment.

Delayed time base: delayed time base sweeps after the time delay set by main time base and delay controls.

Sweep

Ranges: 10 ns/div to 0.1 s/div in 1,2,5 sequence (16 positions). $\pm 3\%$ accuracy with vernier in calibrated position.

Triggering

Internal: dc to > 250 MHz with 1830A plug-in and signals producing 1.0 div or more vertical deflection.

Automatic: delayed sweep is automatically triggered at end of set delay time.

External: dc to > 250 MHz with signals of 20 mV pk-pk or more, increasing to 500 MHz on signals of 50 mV pk-pk or more. Input R, 50 ohms.

Level and slope: internal, at any point on the displayed vertical waveform; external, continuously variable from +100 mV to -100 mV on either slope of trigger signal. Input R, 50 ohms nominal.

Coupling: front panel selection of ac or dc. AC attenuates signals below approx 5 kHz.

Delay (before start of delayed sweep)

Time: continuously variable from 50 ns to 1 s.

Accuracy: $\pm 1\%$ on 50 ms to 0.1 μ s main sweep; linearity $\pm 0.2\%$; time jitter is $< 0.005\%$ (1 part in 20,000) of maximum delay of each step.

Probe power: supplies power to operate one HP active probe.

General

Weight: net, 3.6 lb (1.62 kg); shipping, 7 lb (3.18 kg).

Environment: (Plug-in operates within specifications over the following ranges). temperature, $^{\circ}$ C to $+55^{\circ}$ C; humidity, up to 95% relative humidity to 40° C; altitude, up to 15,000 ft; vibration, vibrated in three planes for 15 minutes each with 0.010 inch excursion, 10 to 55 Hz.

Power: supplied by Model 183 mainframe

Price: Model 1841A, \$1150.

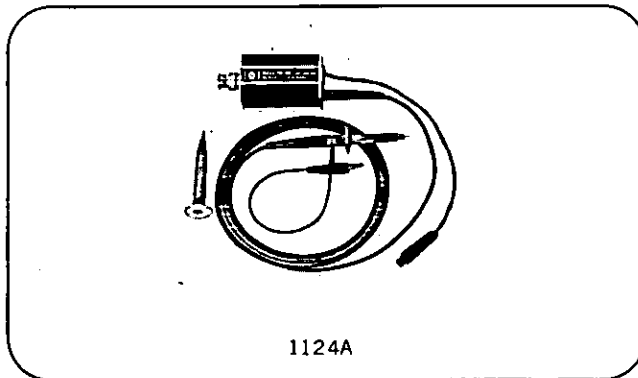

Model 1124A active divider probe provides high voltage, general purpose probing capabilities for 50 ohm input high frequency instruments such as the Model 180 System oscilloscopes. This 10 megohm, 10 pF probe allows direct measurements of up to 100 volts, with its 100:1 division ratio, at a bandwidth from dc to 100 MHz.

Specifications, 1124A

(Specifications apply for a 50 ohm load.)

Bandwidth

DC-coupled: dc to 100 MHz.

AC-coupled: 2 Hz to 100 MHz.

Input RC: 10 megohms shunted by approx 10 pF.

Gain: 0.1 or 0.01, $\pm 5\%$.

Dynamic range: ± 10 V or ± 100 V.

Pulse response: rise time < 3.5 ns; perturbations, 5% pk-pk with < 2.5 ns rise time pulse generator and measured with a 1 GHz sampler.

Drift: $< \pm 500 \mu$ V/ $^{\circ}$ C from 0° C to 55° C ambient temperature.

Maximum safe input: 0.1 gain, ± 300 V; 0.01 gain ± 500 V.

Maximum dc input in ac-coupled mode: ± 200 V.

Accessories supplied: one 6-inch ground lead (HP Part No. 10004-61301) and one retractable hook tip (HP Part No. 10004-67603).

Price: HP Model 1124A, \$95.

FIELD SERVICE OSCILLOSCOPES

35 MHz, Dual Channel, Portable

Models 1700A, 1701A



OSCILLOSCOPES

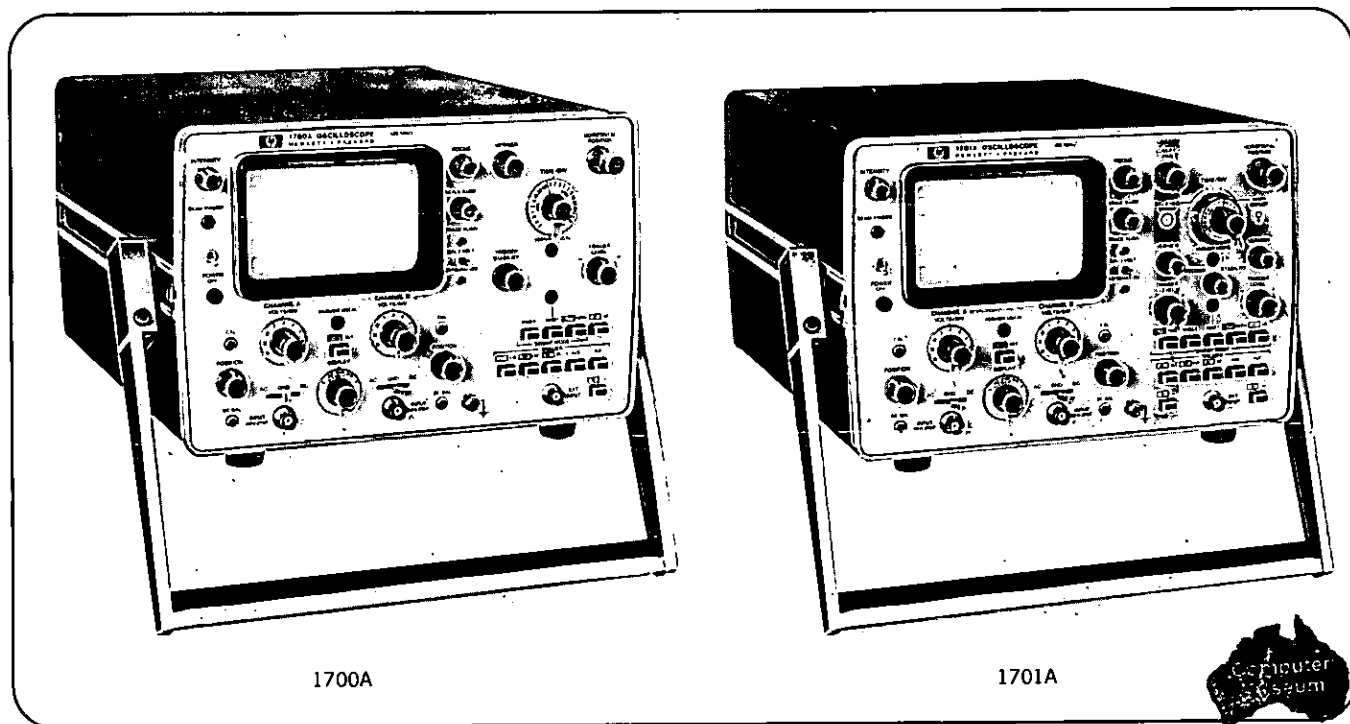

Description

Models 1700A and 1701A are dual channel, 35 MHz bandwidth, 10mV/div deflection factor, portable oscilloscopes with a 6 x 10 cm internal graticule CRT. Model 1700A is a non-delaying sweep oscilloscope with expanded sweep speeds to 10 ns/div and the 1701A provides delayed sweeps to 10 ns/div allowing accurate timing measurements in digital circuits. These light weight scopes (24 pounds without batteries) can be operated from an ac line, dc line (11.5 to 36 volts), or from an optional internal battery. The optional rechargeable nickel-cadmium batteries provide up to 6 hours of operation and a recharge time of approximately 14 hours.

The scopes require less than 18 watts of power which eliminates the need for a fan or ventilation holes in the covers and reduces the amount of internal dust and dirt inherent in a field service environment. Also, the active components in these oscilloscopes operate at approximately 10 to 15% of their power rating which means long term reliability and stable operation. A front panel storage cover protects front panel controls during transportation and provides storage space for probes, power cords, and other accessories.

Specifications Models 1700A and 1701A

Vertical amplifiers

Modes of operation: channel A; channel B, channels A and B displayed alternately on successive sweeps (ALT); channels A and B displayed by switching between channels at approx 100 kHz rate with blanking during switching (Chop); channel A \pm channel B (algebraic addition).

Each channel (2)

Bandwidth: direct or with Model 10006A probe, 3 dB down from 50 kHz, 6 div reference signal from 25 ohm

source; dc-coupled, dc to 35 Mhz; ac-coupled, 10 Hz to 35 MHz.

Risetime: < 10 ns. Direct or with Model 10006A probe, 10% to 90% with 6 div input step from 25 ohm source.

Deflection factor

Ranges: 10 mV/div to 5 V/div (9 ranges) in 1,2,5 sequence. $\pm 3\%$ accuracy with vernier in calibrated position.

Vernier: continuously variable between all ranges, extends maximum deflection factor to at least 12.5 V/div.

Polarity: NORM or INV, selectable on channel B only.

Signal delay: signals are delayed sufficiently to view leading edge of input signals without advanced external trigger.

Input RC: 1 megohm $\pm 2\%$ shunted by 27 pF, ± 1 pF.

Input coupling: AC, DC, or Ground, selectable. Ground position disconnects signal input and grounds amplifier input.

Maximum input

AC-coupled: ± 600 V (dc + peak ac); rms ac < 350 V, 5 V/div to 20 mV/div; 150 V at 10 mV/div (10 kHz or less).

DC-coupled: 350 V(rms) 5 V/div to 20 mV/div; 150 V at 10 mV/div (10 kHz or less).

A + B operation

Amplifier: bandwidth and deflection factors are unchanged; channel B may be inverted for A-B operation.

Common mode (A-B)

Frequency: dc to 1 MHz.

Rejection ratio: at least 40 dB on 10 mV/div, at least 20 dB on all other ranges with verniers set for optimum rejection. Common mode signal amplitude equivalent to 30 div.

Trigger Source: A, B, A+B mode, on displayed signal; Chop and Alternate modes, on channel A only.

Main time base**Sweep**

Ranges: 0.1 μ s/div to 0.2 s/div (20 ranges) in 1,2,5 sequence. $\pm 3\%$ accuracy with vernier in calibrated position.

Vernier: continuously variable between all ranges, extends slowest sweep to at least .5 s/div. Vernier uncalibrated light indicates when vernier is not in Cal position.

Magnifier: expands all sweeps by a factor of 10 and extends fastest sweep to 10 ns/div. Accuracy $\pm 5\%$.

Sweep mode

Normal: sweep is triggered by an internal or external signal.

Auto: bright baseline displayed in absence of input signal. Triggering is same as normal above 40 Hz.

Single: in Normal mode, sweep occurs once with same triggering as normal; reset pushbutton arms sweep and lights indicator; in Auto mode, sweep occurs once each time Reset pushbutton is pressed.

Triggering

Internal: dc to 35 MHz on signals causing 0.5 divisions or more vertical deflection in all display modes except chop; dc to 100 kHz in chop mode.

External: dc to 35 MHz on signals 50 mV pk-pk or more, increasing to 100 mV pk-pk at 75 MHz.

Input RC: 1 megohm, $\pm 2\%$ shunted by approx 27 pF.

Level and slope

Internal: at any point on the vertical waveform displayed.

External: continuously variable from +1.5V to -1.5V on either slope of the trigger signal. (Model 1700A only) from +15 V to -15 V in + 10 setting. Maximum input, ± 100 V.

Coupling: AC, DC, ACF (ac fast), or ACS (ac slow)

AC: attenuates signals below approx 20 Hz.

ACF: attenuates signals below approx 15 kHz.

ACS: attenuates signals above approx 30 kHz.

Trigger stability: time between sweeps continuously variable over a 3:1 range.

Model 1701A Delayed time base**Sweep**

Ranges: 0.1 μ s/div to 0.1 s/div (19 ranges) in 1,2,5 sequence. $\pm 3\%$ with vernier in calibrated position.

Vernier: continuously variable between all ranges, extends slowest sweep to 0.25 s/div.

Triggering

Internal: same as main time base.

Auto: delayed sweep is automatically triggered at end of delay time.

Level and slope: at any point on the vertical waveform displayed.

Coupling: selectable, AC or DC. AC attenuates signals below approx 20 Hz.

Delay time: continuously variable from 0.1 μ s to 2 s.

Delay jitter: < 0.01% (1 part in 10,000) of maximum delay in each step.

Trace intensification: intensifies that part of main time base to be expanded to full screen in delayed time base mode. Rotating time base switch from OFF position activates intensified mode.

Cathode-ray tube and controls

Type: post-accelerator, 19.7 kV accelerating potential; aluminumized P31 phosphor standard (other phosphors available, refer to options)

Graticule: 6 x 10 div internal graticule; 0.2 subdivisions on major horizontal and vertical major axes. 1 div = 1 cm. Front panel adjustment aligns trace with graticule.

Beam Finder: returns trace to CRT screen regardless of setting of horizontal, vertical, or intensity controls.

Intensity modulation: > +4 V, dc to 1 MHz blanks trace of any intensity. Input R, 1000 ohms $\pm 10\%$.

Calibrator: 1 kHz $\pm 10\%$ squarewave, 1 V pk-pk, $\pm 1\%$.

Power requirements

AC line: 115 or 230 V $\pm 20\%$ 48 to 440 Hz, 30 V A maximum at normal line.

DC line: 11.5 to 36 V, 18 watt maximum.

Battery (optional)

Operating time: Up to 6 hours.

Recharge time: 14 hours maximum, with power switch off if not operated after power indicator flashes.

Low battery indicator: power light flashes to indicate that batteries are discharged and further operation may open dc fuse.

Recharging: batteries are recharging whenever power mode switch is set to AC and power is applied. With power switch off, full charge is applied. With power switch on, trickle charge is applied.

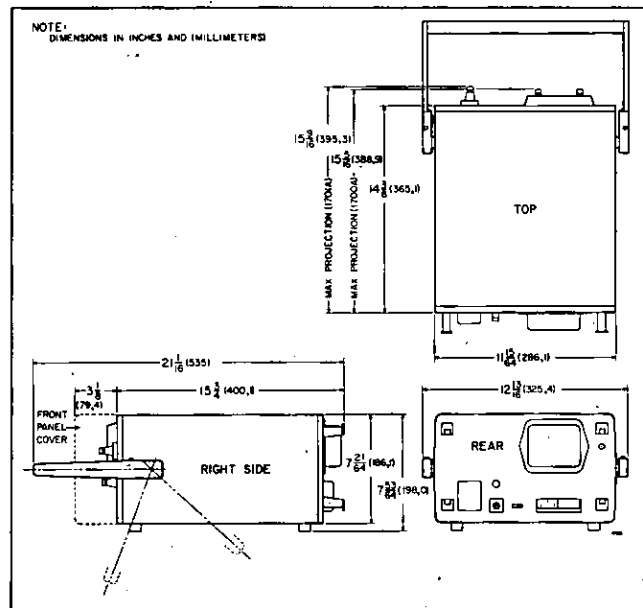
**General****Weight**

Without panel cover: net, 24 lb (11 kg); shipping, 35 lb (16 kg).

With panel cover and accessories: net 27 lb (12 kg); shipping, 38 lb (17 kg).

With panel cover, accessories, and battery pack: net, 35 lb (16 kg); shipping 46 lb (21 kg).

Environment: oscilloscope operates within specifications over the following ranges. Temperature, 0°C to +55°C; humidity, to 95% relative humidity to 40°C; altitude, to 15,000 ft; vibration, vibrated in three planes for 15 min. each with 0.010-inch excursion, 10 to 55 Hz.

Dimensions: refer to outline drawing.

Accessories furnished: mesh contrast filter, Model 10107A; front panel storage cover, Model 10101A; two Model 10006A probes; one dc power plug for assembling a dc power cord; one ac power cord with right angle plug; and one instruction manual.

Price (without battery pack): Model 1700A, \$1680; Model 1701A \$1850.

Options (order by option number)

012: battery pack installed, add \$200.

*005: mixed sweep in model 1701A only;

*006: calibrated sweep delay in 1701A only.

*008: external horizontal input.

*009: channel A output. When cascaded into channel B, provides 1 mV/div deflection factors with reduced bandwidth, *(Price available on request.)

180 SERIES PLUG-IN

50 MHz Dual Channel

Model 1801A, Option 001



OSCILLOSCOPES

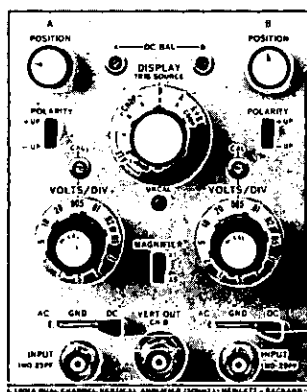

1801A Option 001

Description

Model 1801A Option 001 Dual Channel Vertical Amplifier provides precision measurements from dc to 50 MHz at 5 mV/div in 180 System Oscilloscope mainframes. A times five (X5) mode of operation allows dual channel measurements at 1 mV/div from dc to 20 MHz.

Closely matched input circuit capacitance on each channel assures accurate display of time difference or pulse response of two inputs. All attenuation occurs prior to active components which eliminates trace shift with range changes and assures constant specified bandwidth in each mode of operation. Separate controls for each channel are provided for coupling, attenuating, inverting, and positioning of input signals.

Selectable triggering ends confusion in dual trace measurements. Alternate sweep trigger source may be selected from channel A, channel B, or channel A and B triggered individually for asynchronous signals. For time shared (chop) displays, the trigger may be from channel A or channel B.

Capacitive (AC) or direct (DC) input coupling may be selected. A ground position disconnects the input signal and grounds the amplifier input for a convenient reference. Also, a vernier uncalibrated light indicates when either channel A or B vernier is not in the CAL (detent) position.

Channel B vertical output provides a dc to 40 MHz output signal that can be used to trigger external equipment. Channel B output signal amplitude (with channel B set to 5 mV/div) is 50 mV/div of display. Channel B output can also be cascaded into channel A input, for single channel measurement of 500 μ V/div from dc to 30 MHz.

Specifications

Modes of operation: channel A; channel B; channels A and B displayed on alternate (ALT) sweeps; channels A and B displayed by

switching between channels at approx 400 kHz rate (CHOP), with blanking during switching; channel A plus channel B (algebraic addition).

Each channel (2)

Bandwidth (measured with or without a Model 10004A probe, 3 dB down from 8 div reference signal from a 25 ohm source. Lower limit is approx 0.8 Hz with 10004A probe when accoupled)

DC-Coupled: dc to 50 MHz. In X5 mode, dc to 20 MHz.

AC-coupled: approx 8 Hz to 50 MHz; in X5 mode, 8 Hz to 20 MHz.

Rise time: (measured with or without 10004A probe 10% to 90% of 8 div input step from 25 ohm source). < 7 ns; in X5 mode, < 18 ns.

Deflection factor: 5 mV/div to 20 V/div (12 positions) in 1, 2, 5 sequence. X5 mode increases deflection factor to 1 mV/div. With channel B output cascaded with channel A, (X1 mode) 500 μ V/div.

Attenuator accuracy: $\pm 3\%$.

Vernier: provides continuous adjustment between deflection factor settings: extends maximum deflection factor to at least 50 V/div.

Polarity: +up or -up, selectable.

Signal delay: input signals are delayed sufficiently to view leading edge of input pulse without advanced external trigger.

Input RC: 1 megohm shunted by approx 25 pF; constant on all ranges.

Input Coupling: selectable AC, DC, or Ground. Ground position disconnects signal input and grounds amplifier for reference.

Maximum input

DC-coupled: ± 150 V (DC + peak AC) on 5 mV/div and ± 350 V (DC + peak AC) on other ranges at 10 KHz or less;

AC-coupled: ± 600 Vdc.

A + B operation

Amplifier: bandwidth and deflection factors are unchanged; either channel may be inverted for $\pm A \pm B$ operation.

Differential input (A-B) common mode: for frequencies from dc to 1 MHz, CMRR is at least 40 dB at 5 mV/div and at least 20 dB on other ranges for common mode signals of 24 div or less (X1).

Triggering

Source: A, B, A + B modes, on the signal displayed.

Chop mode: on channel A or channel B signal.

Alternate mode: on channel A signal, channel B signal, or successively (comp) from the displayed signal on each channel.

Frequency: dc to 50 MHz on signals causing 0.5 division or more vertical deflection in all display modes except chop X1; dc to 100 kHz in chop mode.

Channel B vertical signal output X1

Rise time

Vertical signal out: 9 ns (40 MHz)

Cascaded B into A: 12 ns (30 MHz)

Amplitude: 50 mV into 50 Ω , usable amplitude up to 800 mV pk to pk. Open circuit, approx 8 mV/div with the usable amplitude greater than 1V.

DC level: 0 V \pm 10 mV at center screen

Output R: approx 50 ohms.

General

Weight: net, 4 lb. (1.8 kg); shipping, 7 lb. (3.2 kg).

Environment

Same as 180A/AR except temperature which is 0°C to + 55°C.

Accessories furnished: two Model 10004A, 10:1 voltage divider probes, over-all length approx 3 $\frac{1}{2}$ feet.

Price: Model 1801A Option 001, \$845

Other Options (order by option number)

090: two 10006A 10:1 voltage divider probes (6 ft. cable) instead of two 10004A probes. Add \$10.

091: two 10005A 10:1 voltage divider probes (10 ft. cable) instead of two 10004A probes. Add \$10.

OSCILLOSCOPES



180/140 SERIES 500 kHz Amplifier, 18 GHz Sampler Models 1806A, 1430B

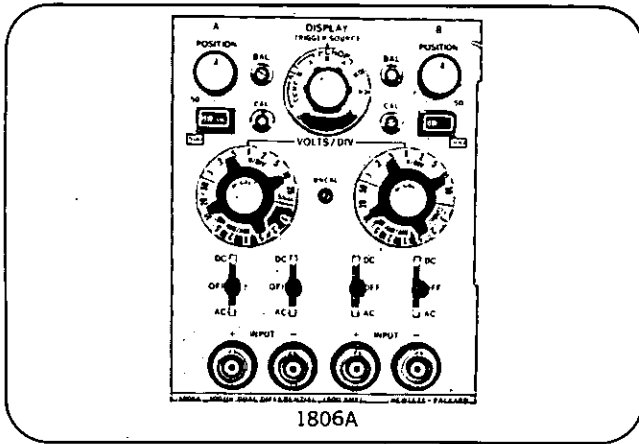

Model 1806A Description

Model 1806A Dual Channel Vertical Amplifier provides the capability to accurately measure and analyze low level, low frequency signals in the 180 oscilloscope system. Covering the dc to 500 kHz range with 100 $\mu\text{V}/\text{div}$ deflection factor, this plug-in provides accurate two channel low level measurements throughout the low frequency spectrum in applications such as: electro-mechanical use in vibration checks, servo testing, general audio measurements, power supply ripple, and checkout of medical monitoring systems or instruments.

Operating characteristics are: dc to 500 kHz bandwidth, 100 $\mu\text{V}/\text{div}$ to 20 V/div deflection factors, 100 dB CMRR from dc to 10 kHz with a ± 10 V common mode signal on the 100 $\mu\text{V}/\text{div}$ range and less than 20 μV of noise (measured tangentially) at full bandwidth.

Specifications, 1806A

Modes of operation

Channel A alone; channel B alone; channels A and B displayed alternately on successive sweeps (ALT); channel A and B displayed by switching between channels at approx. 100 kHz rate (CHOP) with blanking during switching.

Each channel

Bandwidth: dc-coupled, dc to 500 kHz; ac-coupled, 2 Hz to 500 kHz.

Bandwidth Limit Switch: allows upper bandwidth to be reduced to approx 50 kHz.

Deflection factor.

Ranges: 100 $\mu\text{V}/\text{div}$ to 20 V/div (17 positions) in 1, 2, 5 sequence

Attenuator accuracy: $\pm 3\%$ with vernier in calibrated position.

Vernier: continuously variable between ranges; extends maximum deflection factor to at least 50 V/div.

Noise: < 20 μV measured tangentially at full bandwidth.

Input: differential or single-ended on all ranges, selectable.

Common mode

Frequency: dc to 10 kHz on all ranges.

Rejection ratio: ≥ 100 dB (100,000:1) with dc-coupled input on 100 $\mu\text{V}/\text{div}$ range, decreasing 20 dB per decade of deflection factor to ≥ 40 dB on the 200 mV/div range; CMRR is 30 dB on the 500 mV/div to 20 V/div ranges.

Maximum signal: ± 10 V (dc + peak ac) on 100 $\mu\text{V}/\text{div}$ to 200 mV/div ranges; ± 400 V (dc + pk ac) on other ranges.

Input coupling: selectable AC, DC, or OFF for + and - inputs. Off disconnects signal input and grounds amplifier input.

Input RC: 1 megohm shunted by approx 45 pF, constant on all ranges.

Maximum input: ± 400 V (dc + peak ac).

Input isolation: ≥ 80 dB between channels at 500 kHz with shielded input connectors.

Triggering

Source: on channel A signal for A, Chop, or Alternate displays; on channel B signal for B, Chop, or Alternate; on composite A and B for alternate.

Frequency: dc to > 500 kHz on signals causing 0.5 div or more vertical deflection in all display modes except chop; dc to 100 kHz in chop mode.

General

Weight: net 3 1/2 lb (1,59 kg); shipping 6 1/2 lb (2,95 kg).

Environment: (Plug-in operates within specifications over the following ranges.) temperature, 0°C to 55°C; humidity, to 95% relative humidity to 40°C; altitude, to 15,000 ft; vibration, vibrated in three planes for 15 min. each with 0.010 inch excursion, 10 to 55 Hz.

Price: Model 1806A, \$675.

Accessories furnished: two BNC to dual banana plug/binding post adapters. HP Part No. 1250-1264.

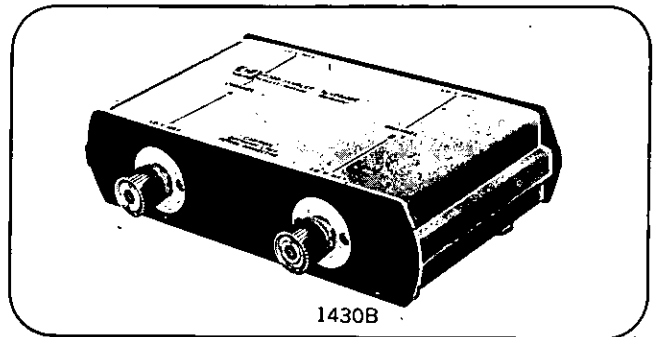

Model 1430B Description

Model 1430B sampler provides the 140 system with 20 ps rise time with low overshoot for accurate measurements of fast rise pulses to 18 GHz. The feedthrough measurement technique, allows the system load to remain connected for an actual measurement of the system operating characteristics. Terminated measurements can also be made, if desired, by using the 50 ohm loads (Model 909A) which are supplied as standard accessories.

Specifications, 1430B

Rise time: approx 20 ps. < 28 ps observed with 1105A/1106A pulse generator and 909A 50 ohm load.

Bandwidth: dc to > 18 GHz.

Overshoot: < 7.5%.

Noise: < 10 mV unsmoothed, < 2.5 mV smoothed. Both measured tangentially.

Dynamic Range: ± 1 volt.

Low frequency distortion: < $\pm 5\%$.

Maximum safe input: ± 3 V.

Input characteristics

Electrical: 50 ohm feedthrough, dc-coupled. Reflection from sampler is approx 10%, using a 40 ps TDR system. Pulses emitted from sampler input are approx 10 mV in amplitude and 5 ns in duration.

Mechanical: Amphenol APC-7 precision 7 mm input and output connectors.

Time difference between channels: < 5 ps.

Connecting cable length: 5 ft. (see options for longer cables).

Weight: net, 4 lb (1,8 kg); shipping, 9 lb (4,1 kg).

Accessories provided: two Amphenol APC-7 to female Type N adapters (HP Model 11524A). Two 50 ohm loads (HP Model 909A).

Price: Model 1430B, \$3,500.

Options: (order by option number)

CO1: 10-ft connecting cable (5-ft is standard). Add \$35.

SAMPLING PLUG-IN

1 GHz Bandwidth, 2mV/div Model 1810A



OSCILLOSCOPES

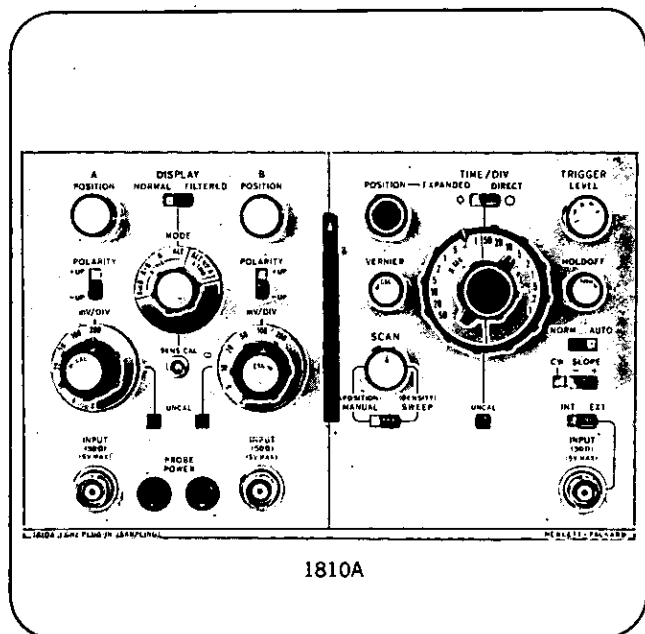

Description

Model 1810A Sampling plug-in is a 1 GHz, dual channel, double-sized plug-in for 180 System Oscilloscope mainframes. This plug-in has easy-to-use controls that look and operate like real-time plug-ins, which reduces familiarization time and measurement errors.

With this plug-in, you can make accurate measurements of repetitive signals from dc to greater than 1 GHz with deflection factors from 2 mV/div to 200 mV/div. A unique sampling circuit maintains a sampling efficiency of 100% for all input signal levels, which eliminates external adjustments and makes sampling measurements as easy as real time measurements. Also, internal triggering with built in delay lines allows triggering on the displayed waveform without requiring an external trigger input.

Specifications, 1810A

Modes of operation: channel A; channel B; channels A and B displayed on alternate samples (ALT); channel A plus channel B (algebraic addition); and channel A versus channel B.

Vertical channels

Bandwidth: dc to 1 GHz.

Rise time: < 350 ps.

Pulse response: < 3%, overshoot and perturbations.

Deflection factor

Ranges: 2 mV/div to 200 mV/div (7 calibrated positions) in 1,2,5 sequence.

Accuracy: $\pm 3\%$.

Vernier: provides continuous adjustment between all deflection factor ranges; extends maximum deflection factor to < 1 mV/div.

Polarity: +UP or -UP.

Dynamic range: > 1.6 V.

Positioning range: > ± 1 V on all deflection factors

Input R: 50 ohms, $\pm 2\%$

Maximum input: ± 5 V (dc + peak ac)

VSWR: < 1.1:1 to 300 MHz increasing to < 1.5:1 at 1 GHz.

Reflection coefficient: < 6% measured with HP Model 1415A TDR.

Noise

Normal: < 1 mV observed from center 80% of dots.

Smoothed: < 0.5 mV.

Isolation between channels: ≥ 40 dB with 350 ps risetime input.

A + B operation: bandwidth and deflection factors are unchanged; either channel may be inverted for $\pm A \pm B$ operation.

Vertical outputs: an uncalibrated, ± 1 V approx full screen amplitude vertical output signal from each channel is provided at the rear panel of all 180 system mainframes.

Time base

Ranges

Normal: 10 ns/div to 50 μ s/div (12 calibrated positions) in a 1,2,5 sequence. $\pm 3\%$ accuracy with vernier in calibrated position

Expanded: direct expansion up to $\times 100$ in seven calibrated steps on all normal time scales extends the range to 100 ps/div. Accuracy is $\pm 4\%$. (10 ps/div, $\pm 10\%$ using the mainframe magnifier.)

Vernier: continuously variable between ranges; increases fastest sweep to < 40 ps/div.

Sweep mode

Normal: sweep is triggered by internal or external trigger.

Automatic: baseline is displayed in absence of input signal.

Triggering

Internal

Source: selectable, channel A triggers channel A or alternate channel B triggers channel B, alternate, A + B or A vs B.

Sine wave: jitter 30 ps plus 1% of one period, 30 mV pk-pk for signals from 1 kHz to 300 MHz, for CW signals from 300 MHz to 1 GHz, trigger amplitude increases linearly from 30 mV to 200 mV pk-pk. Useful triggering can be obtained with 5 mV signals.

Pulse: 30 mV pk, 3 ns wide pulses provide 30 ps jitter. Useful triggering can be obtained with 5 mV signals.

External

Sine wave: jitter < 30 ps plus 1% of one period, from 1 kHz to 1 GHz on signals of 30 mV pk-pk, useful triggering can be obtained with 5 mV signals.

Pulse: 30 mV pk, 3 ns wide pulses provide < 30 ps jitter. Useful triggering can be obtained with 5 mV signals.

Auto: 50 mV pk-pk for CW signals from 200 Hz to 200 MHz, jitter < 30 ps plus 1% of one period (may be used to 1 GHz with increased jitter). Pulse triggering requires 50 mV pk, 3 ns wide pulses for < 30 ps jitter.

Level and slope: continuously variable from +800 mV to -800 mV on either slope of the sync signal for internal or external triggering.

Coupling: ac coupling attenuates signals below approx 1 kHz.

Trigger stability

Variable hold off: variable over at least a 3:1 range in all sweep modes.

Marker position: intensified marker segment indicates point about which the sweep is to be expanded.

Scan

Internal: dot density continuously variable from 100 to 1000 dots full screen or from 500 to 5000 dots in filtered mode.

Manual: X-axis positioned by front panel control.

Horizontal output: an uncalibrated 0 to approx 0.75 V amplitude signal is provided at the rear panel of a 180 or 181 mainframe.

General

Weight: net, 6 $\frac{1}{2}$ lb (2,95 kg); shipping 11 $\frac{1}{2}$ lb (5,22 kg).

Environment

Plug-in: operates within specifications over the following ranges.

Temperature: 0°C to 55°C

Humidity: to 95% relative humidity to 40°C.

Altitude: to 15,000 ft.

Vibration: vibrated in three planes for 15 min. each with 0.010 inch excursion, 10 to 55 Hz.

Price: Model 1810A, \$1650.



NARROW BAND TDR

3.5 to 12 GHz

Models 1580A

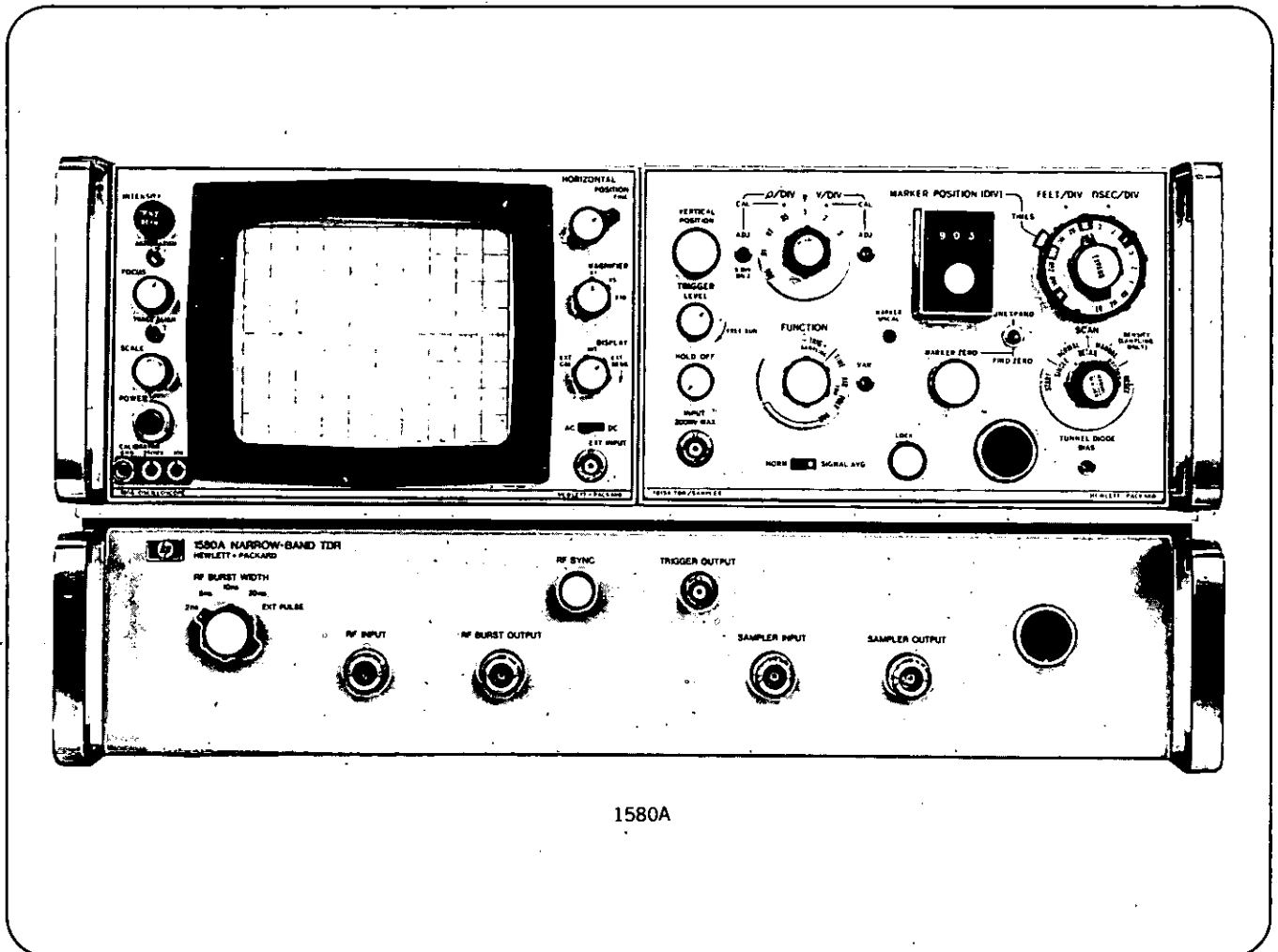

Description

Model 1580A Narrow Band TDR provides a quick, portable method of determining the locations and magnitude of discontinuities in waveguide or band pass coaxial transmission systems. It will determine the magnitude of resistive or reactive discontinuities which may disrupt system performance such as faults created by misaligned or corroded waveguide flanges and coaxial cable connectors, foreign objects inside waveguide, and crushed waveguide or coaxial cable. The 1580 provides increased ease of use over CW methods in systems with many reflections or sources of loss. With CW methods using standing wave patterns, a technician may have a difficult problem in locating and correcting multiple reflections. Narrow band TDR clearly shows the individual reflections with their position directly calibrated in feet or meters from the source, allowing rapid repair or system set-up.

Narrow band TDR is similar in concept to radar in that an rf pulse burst is transmitted down a system and, if a discontinuity exists in the system, energy is reflected back to the source and is detected and displayed by the Model 1580A system. The use of an rf pulse burst concentrates the incident energy in the band of interest. By contrast, a wide band (step

type) TDR produces energy from dc to some upper cut off frequency. When the step from a wide band TDR is applied to a waveguide, for instance, incident energy below the cut off frequency is reflected and only the small amount of energy above the cut off frequency is available for system analysis. The rf pulse burst allows the incident energy to be contained within the dominant mode of the waveguide or the passband of a narrow band system which increases sensitivity and resolution over wide band TDR in bandpass systems. Therefore, the advantage of time separation of discontinuities is maintained.

Variable burst widths from 2 to > 50 ns are provided by the Model 1580 so that the bandwidth of the spectrum of the incident RF burst may be matched to the characteristics of the system being tested. This is especially useful when evaluating waveguide systems where consideration must be given to the effects of dispersion that causes the reflected RF burst to widen in time and loose amplitude. The effect that dispersion will have on the rf pulse depends on the center frequency of the pulse, its duration, and the length of the waveguide. For a given waveguide system, there is an optimum pulse width for best resolution. An external burst width input allows selection of other burst widths for special applications.

The smallest discontinuity which may be resolved by a

TDR system is determined by its amplitude resolution which is the ratio of the amplitude of the incident RF burst to the amplitude of the smallest return signal that may be seen above the system noise. The greater than 100:1 amplitude resolution of the 1580 allows return losses of -40 dB and greater to be detected if 70 mw of rf power is available.

The Model 1580 also has all of the features of the Model 1815A/B TDR/Sampler and Model 1817A Sampler including sampling capability from dc to 12.4 GHz and the ability to

make step TDR measurements (with the addition of an external 1106A Tunnel Diode Mount) in lines as long as 10,000 feet.

Model 1580 Narrow Band TDR System consists of a standard Model 180AR Rack model oscilloscope mainframe, either a 1815A (calibrated in feet) TDR/Sampler Plug-in and the 1580A Narrow band TDR rf burst generator/sampler. Basic operation of the Narrow band TDR system is illustrated in the block diagram.

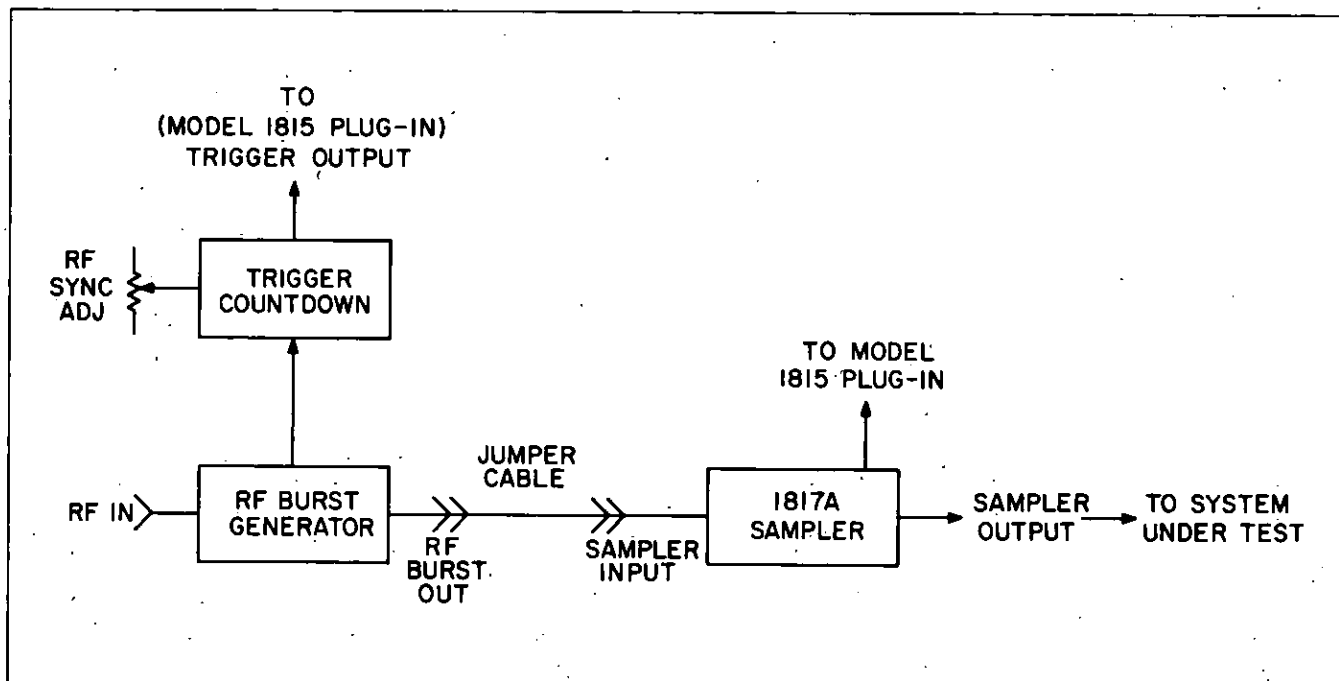

Specifications

System

Frequency: 3.5 to 12 GHz. Measurements from 1 GHz to 18 GHz may be obtained by replacing the internal isolator.

Output RF burst pulse width at center frequency of the rf source: continuously variable from 2 ns to >50 ns.

Amplitude resolution: > 40 dB (from 3.5 to 12 GHz) with 70 mw signal source such as HP Models 8690B or 8692A. With signal sources < 70 mw vertical resolution decreases. An internal trigger source provides a coherent display of RF burst on 10 ns/div (ft/div) or faster ranges with > 10 mw of input power which allows signal averaging to be used for increased vertical resolution.

Time for internal perturbations to settle within 5% of baseline: < 10 ns after end of RF burst.

System noise level: < 8 mV.

Required interconnections: low loss cable or waveguide

RF burst generator

Insertion loss: ≤ 10 dB.

Pulse rise time: typically 1.5 ns on narrowest pulse.

Output VSWR: < 1.5:1.

Output pulse burst width: from < 2 to > 50 ns which corresponds to bandwidths from 500 to < 20 MHz.

Maximum RF input: +25 dBm.

Trigger countdown: provides coherent rf burst from 3.5 to 12 GHz for signals above +10 dBm.

Sampler

Maximum safe input: ± 3 V.

Input operating range: 2 V pk-pk.

Oscilloscope mainframe: standard model 180AR oscilloscope, refer to page 521 in HP 1970 Catalog or 180 system data sheet for specifications.

Model 1815A or 1815B TDR/Sampler plug-in: a modified (Option 001) plug-in that accepts external triggering in the TDR mode. Refer to page 528 in HP 1970 Catalog or 1815A/B data sheet for specifications. Model 1815A is calibrated in ft/div and Model 1815B is calibrated in meters/div. Plug-in may be used as standard TDR (wideband) with trigger level control in max cw position.

Weight: net, 70 lb (31.8 kg); shipping, 90 lb (40.8 kg).

Price: Model 1580A, \$6000.

COUNTERS & FREQ/TIME STANDARDS



UNIVERSAL COUNTERS

Unique Capabilities in 50 & 550 MHz Counters
5326/5327 Family

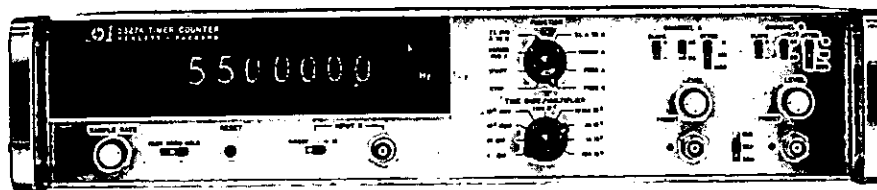

5327A

Advantages

- 550 MHz or 50 MHz frequency range
- Internal integrating digital voltmeter
- Switchable front and rear frequency inputs
- Read A & B trigger levels digitally — precisely
- Dual FET differential amplifier inputs
- Dual trigger level controls
- Remote programming of all functions
- Minimum 100 μ s sample rate
- BCD output with buffer storage
- Readout blanking of undesirable zeros to left of count total

Uses

- Measure frequency
- Measure period, period average
- Measure time interval, time interval average
- Measure dc voltage
- Quantitative time interval measurements
- Count random input pulses
- Scale input signals up to 10^8

Unique Measurement Benefits

The Hewlett-Packard 5326/5327 Universal Counters are both general-purpose lab instruments and fast, efficient systems instruments. Frequency measurements to 550 MHz, high resolution time interval measurements, and voltage measurements make the 5326/5327 family the most useful. Timer/Counter/DVM's available (see chart below). A single set of controls and one readout provide either frequency or voltage data which leads to easy manual operation. Systems interface is greatly simplified since a single programming connector and a single BCD connector serve both the counter and DVM sections.

New Features

Many new features are offered with the 5326/5327 Family which provide unique measurement benefits. The exclusive

HP feature of readout blanking suppresses unwanted zeros to the left of the most significant digit to improve clarity of the digital presentation. The new function of Time Interval Averaging provides the capability of high resolution (1 ns or better) averaged time interval measurements on repetitive input signals. 550 MHz frequency capability with low cost and good reliability is provided by new HP high frequency monolithic integrated circuits. An internal integrating DVM in the 5326B allows, in addition to standard dc measurements, the ability to measure with digital precision the internal trigger levels of the A and B input channels. This feature adds a whole new dimension to Time Interval measurements. Full details on these new techniques are in the April 1970 Hewlett-Packard Journal.

Hysteresis compensated slope selection has been added to the 5326/5327 Family to further enhance its usefulness and ease of operation when making time interval measurements. Now, when switching from + to - slopes, the trigger level need not be readjusted, since the trigger points remain at the same value. The 5326/5327 also provides front panel trigger lamps which indicate when the attenuator and level controls are properly set to trigger on the applied input signal.

The HP 5326/5327 Family has ac or dc coupled, level-controllable, differential input amplifiers, dual in the 5326A/B and 5327A and single channel in the 5326C and 5327C. Their unique differential Schmitt trigger circuits have a threshold band (error zone) of less than 1 mV to protect against false counting. Trigger level settings are, thus, clear cut and well defined for a "count" or "no count", and undesired signals and noise below the trigger levels are rejected. These controls also select the start-stop points in time interval measurements. A three-step attenuator changes the control range in decades of X1, X10, and X100 with an adjustable level control providing a trigger level range of ± 3 volts times the attenuator setting. A separate/common switch allows the inputs to operate from separate input signals or a single input signal. This design results in high stability, high sensitivity, and an input impedance of 1 M Ω shunted by less than 25 pF.

5326/5327 Family Selection

Model	Description	Frequency Range	Period Average Totalize / Ratio Scaling	Time Interval Time Interval Averaging	DVM (D.C. Voltage)	Price
5326C	Multi-Function Counter	50 MHz	██████████	██████████		\$ 950
5326A	Universal Timer/Counter	50 MHz	██████████	██████████		\$1195
5326B	Universal Timer/Counter/DVM	50 MHz	██████████	██████████		\$1550
5327C	Multi-Function Counter	550 MHz	▨▨▨▨▨▨	▨▨▨▨▨▨		\$1550
5327A	Universal Timer/Counter	550 MHz	▨▨▨▨▨▨	▨▨▨▨▨▨		\$1795

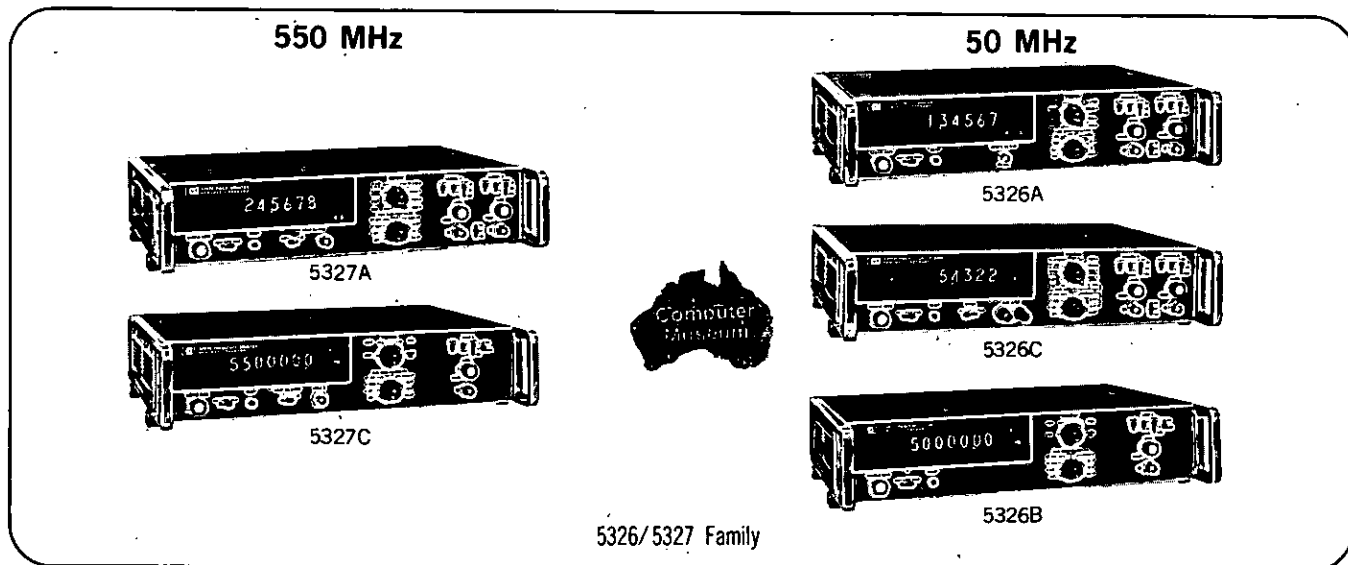

Measurements

The 5326 Series measures frequencies from 0-50 MHz and the 5327 Series extends this range to 550 MHz with either periodic or random signals. Each counter's gate time is selectable in decade steps from 0.1 μ s through 10 s with the decimal point and units automatically displayed. The rear panel frequency input is front panel selectable for use with external scaling devices or for system applications.

The 5326A/B and 5327A will measure the period of a single input cycle with a selectable resolution of 0.1 μ s to 10 s for frequencies from dc to 10 MHz. Periods are fully displayed with a 7 digit readout (8 digits optional); e.g., 999999.9 μ s. If the count exceeds the number of digits in the readout, an overflow lamp lights on the front panel.

Period average measurements are provided with each member of the 5326/5327 Family to reduce the effect of trigger error and \pm one count ambiguity. Periods averaged are selectable from 1 to 10^8 ($10 \cdot 10^7$ when prescaling) in decade steps for input rates from 0 to 10 MHz. Period average measurements result in higher accuracy at low frequencies and faster measurements at high frequencies for equivalent resolution.

Time intervals of 0.1 μ s to 10^8 s can be measured with the 5326A/B and 5327A. Rear panel BNC connectors furnish Channel A and Channel B marker pulses, 1 μ s wide, for displaying trigger levels with an oscilloscope or they may be used for actuating other circuits.

Time Interval Averaging capability is also offered in the 5326A/B and 5327A to provide time interval measurements ranging from 0.15 ns to 10 s. Optimum resolution of these measurements made on repetitive signals is 100 ns/ $\sqrt{\text{intervals averaged}}$. Since a measurement can be averaged over 10^8 intervals, maximum resolution can be less than 100 ps.

The 5326B offers dc voltage measurements in addition to the above described capability. DC ranges of 10, 100 and 1000 volts have autopolarity and measurement times front panel selectable from 1 ms (2 digits) to 1 sec (5 digits). The highly linear and stable V-F Converter affords excellent accuracy.

5326A/B And 5327A Specifications

Input Channels A and B

Range: dc coupled: 0-50 MHz
ac coupled: 20 Hz - 50 MHz

Sensitivity: 0.1 V rms sine wave.
0.3 V p-p pulse.

8 ns minimum pulse width.

Sensitivity can be decreased by 10 or 100 times, using the ATTENUATOR switch.

Quantitative Time Interval

The 5326B has two functions which make it absolutely unique among universal counter/timers. The READ A and READ B functions allow the DVM to accurately measure the 2 internal input amplifier trigger points to within ± 10 mV, and display that value. Consequently, 50% point, 10%-90% rise time points, and others can be accurately set for time interval measurements by using the internal DVM functions. Coupling the Time Interval Averaging capability to the foregoing yields an extremely powerful measurement tool—quantitative time interval. This measurement accurately determines both relevant signal parameters—time between measure points and their respective levels.

Systems Compatibility

Each member of the 5326/5327 family can be effectively used as a fast, efficient systems instrument.

Option 003 provides 4-line 1-2-4-8 BCD output with "1" state positive. This output is suitable for systems use or for output devices such as the HP Model 5050B or 5055A Digital Recorders.

Option 002 and Option 004 provide remote programming capability via contact closure to ground or DTL drive. A rear panel connector provides access to all programmable circuits. With Option 002 all front panel controls are single line programmable except the FAST/NORM MODE, SEPARATE-COMMON switch (the CHECK position is programmable on the 5326A/B and 5327A only), input attenuators, and ac-dc input coupling switches. With Option 004 all front panel controls including all signal input conditioning are single line programmable except the FAST/NORM MODE. Both Options 002 and 004 provide programmable trigger level controls through single line analog signals.

In addition, the HP 10542A Remote Programming Interface provides two digital-to-analog converters to enable the 5326/5327 series with Option 004 to be completely programmed from a 40-bit digital output register.

Impedance: 1 M Ω shunted by less than 25 pF.

Dynamic input voltage range:

0.1 to 3 V rms ac times attenuator setting.

± 5 V dc times attenuator setting.

Trigger Level: PRESET to center triggering about 0 V or variable over the range of -3V to +3V times attenuator setting. Trigger threshold band < 1.0 mV, referred to input at maximum frequency.

Overload Protection: 250 V rms on all attenuator settings, except 25 V rms on X1 above 50 kHz.

Slope: Independent selection of positive or negative slope.
Channel Inputs: Common or separate lines.
Marker Outputs: Rear panel BNC's. DTL pulse, low for approx. 1 μ s after trigger point for A and B channels.

Input Channel C And C + 10

Range: 5326A/B: Channel C: dc coupled; 0-50 MHz
 5327A: Channel C: ac coupled; 1 kHz-50 MHz; C + 10 (prescale); 0-550 MHz.
Sensitivity: 5326A/B: 50 mV rms sine wave to 30 MHz;
 100 mV rms to 50 MHz.
 5327A: Channel C: 5 mV rms; C + 10 (prescale): 100 mV rms.
Impedance: 50 Ω nominal
Maximum Input: 5 volts rms; 7.5 volts peak
Trigger Level: 0 volts
Locations: 5326A Front Panel
 5326B Rear Panel
 5327A Front Panel

Start (Totalizing and Scaling)

Range: 0 - 10 MHz
Factor: 1 - 10⁶ selectable in decade steps.
Output: Rear panel TIME BASE BNC.
Display: Channel A input divided by scaling factor.

Frequency

Range: 5326A/B: 0 - 50 MHz
 5327A: 0 - 50 MHz (direct)
 0 - 550 MHz (prescaled).
Input: 5326A/B: Channel A or Channel C (switchable).
 Channel A provides triggered frequency measurement.
 5327A: Channel A; channel C for direct and C + 10 for prescaled (switchable). Channel A provides triggered frequency measurement.
Gate Times: 0.1 μ s to 10 s in decade steps
Accuracy: Direct: ± 1 count \pm time base accuracy
 Prescaled: ± 10 counts* \pm time base accuracy
Display: MHz, kHz, or GHz with positioned decimal point.

Integrating Digital Voltmeter (5326B Only)

Technique: Voltage-to-frequency conversion
Voltage Ranges: Manual selection.

Range (V dc)	Resolution (1 sec, integration time)	Input Impedance
10	100 μ V	> 1000 M Ω
100	1 mV	10 M Ω
1000	10 mV	10 M Ω

Input: Single ended.
Polarity: Automatic polarity detection.
Overrange: 25% overrange on 10 V and 100 V ranges with full accuracy.
Overload Protection: 1100 V dc all ranges
Accuracy: After 10 minutes warm-up (within 90-day calibration period).

Input Channel A

Range: dc coupled: 0 - 50 MHz.
 ac coupled: 20 Hz - 50 MHz.
Sensitivity: 0.1 V rms sine wave.
 0.3 V p-p pulse
 8 ns minimum pulse width
 Sensitivity can be decreased by 10 or 100 times, using the ATTENUATOR switch.
Impedance: 1 M Ω shunted by less than 25 pF.
Dynamic input voltage range:
 0.1 to 3 V rms ac times attenuator setting.
 ± 5 V dc times attenuator setting.
Trigger Level: PRESET to center triggering about 0 V or variable over the range of -3 V to +3 V times attenuator setting. Trigger

Time Interval

Range: 0.1 μ s to 10⁹ seconds.
Input: Channels A and B; can be common or separate.
Frequency Counted: 10 MHz to 0.1 Hz in decade steps.
Accuracy: ± 1 count \pm time base accuracy \pm trigger error.**
Display: μ s, ms, seconds or 10's of seconds with positioned decimal point.

Time Interval Average

Range: 0.15 ns to 10 s.
Intervals Averaged: 1 - 10⁸ selectable in decade steps.
Input: Channels A and B; can be common or separate.
Frequency Counted: 10 MHz
Accuracy: \pm time base accuracy ± 2 ns $\pm \frac{(\text{trigger error}^{**} \pm 100 \text{ ns})}{\sqrt{\text{intervals, averaged}}}$
Display: ns, μ s with positioned decimal point.

Period

Range: 0 - 10 MHz
Input: Channel A.
Frequency Counted: 10 MHz to 0.1 Hz in decade steps.
Accuracy: ± 1 count \pm time base accuracy \pm trigger error***
Display: μ s, ms, seconds or 10's of seconds with positioned decimal point.

Period Average

Range: 0 - 10 MHz
Periods Averaged: 1 - 10⁸ selectable in decade steps.
Input: Channel A.
Frequency Counted: 10 MHz
Accuracy: ± 1 count \pm time base accuracy \pm trigger error***
Display: ns, μ s with positioned decimal point.

Ratio

Display: (Any input function)/F_{ext} times Multiplier (M). M = 1 to 10⁸ (10-10⁹ when prescaling) selectable in decade steps.
Range: Range of input function: See appropriate function section.
 F_{ext}: (External Oscillator Input) 100 Hz - 10 MHz
Mode: Any input function.
Accuracy: Accuracy of selected input function \pm trigger error of F_{ext}

Range	Stability (% of Reading)	Linearity (% of Range)	Zero Drift (% of Range)	Counter
10V	$\pm 0.04\%$	$\pm 0.01\%$	$\pm 0.01\%$	± 1 count
100V	$\pm 0.04\%$	$\pm 0.01\%$	$\pm 0.01\%$	± 1 count
1000V	$\pm 0.08\%$	$\pm 0.01\%$	$\pm 0.01\%$	± 1 count

Operating Temperature: 10°C to 40°C, < 80% RH.

Measurement Time:

1 msec	2 digits	Decimal points automatically displayed
10 msec	3 digits	
100 msec	4 digits	
1 sec	5 digits	
10 sec	6 digits	

Response Time: < 100 μ s for full accuracy with a step function input.

AC Noise Rejection: > 60 dB for multiples of 10 Hz; 100 ms integration time.

5326C And 5327C Specifications

threshold band < 1.0 mV, referred to input at maximum frequency.
Overload Protection: 250 V rms on all attenuator settings, except 25 V rms on X1 above 50 kHz.
Slope: Independent selection of positive or negative slope.

Input Channel B And B + 10 (5327C Only)

Range: Channel B: ac coupled, 1 kHz-50 MHz; B + 10: dc coupled, 0-550 MHz
Sensitivity: Channel B: 5 mV rms; B + 10 (prescaled): 100 mV rms
Impedance: 50 Ω nominal
Maximum Input: 5 volts rms, 7.5 volts peak
Trigger Level: 0 volts

Start (Totalizing and Scaling)

Range: 5326C: 0 - 10 MHz
5327C: 0 - 10 MHz (direct)
0 - 100 MHz (prescaled)
Factor: 5326C: 1 - 10^8 in decade steps
5327C: Channel A or Channel B: 1 - 10^8 in decade steps;
B + 10: $10 \cdot 10^9$ ($1 \cdot 10^8$ on selector) in decade steps
Output: Rear panel TIME BASE BNC
Display: Channel A, B, or B + 10 input divided by scaling factor.

Frequency

Range: 5326C: 0 - 50 MHz
5327C: 0 - 50 MHz (direct)
0 - 550 MHz (prescaled)
Input: 5326C: Channel A. Channel A provides triggered frequency measurement.
5327C: Channel A; Channel B for direct, and B + 10 for prescaled (switchable). Any channel provides triggered frequency measurement.
Gate Times: 0.1 μ s to 10s in decade steps
Accuracy: Direct: ± 1 count \pm time base accuracy.
Prescaled: ± 10 counts* \pm time base accuracy.
Display: MHz, kHz or GHz with positioned decimal point.

Period Average

Range: 5326C: 0 - 10 MHz
5327C: 0 - 10 MHz (direct)

0 - 100 MHz (prescaled)

Periods Averaged 5326C: 1 - 10^8 in decade steps.
5327C: Channel A or Channel B: 1 - 10^8 in decade steps; B + 10: $10 \cdot 10^9$ ($1 \cdot 10^8$ on selector) in decade steps

Frequency Counted: 10 MHz

Accuracy: Direct: ± 1 count \pm time base accuracy \pm trigger error***
Prescaled: ± 10 counts* \pm time base accuracy \pm trigger error***

Display: ns, μ s with positioned decimal point.

Ratio

Display: (Any input function)/ F_{ext} times Multiplier (M). M = 1 to 10^8 ($10 \cdot 10^9$ when prescaling) selectable in decade steps.

Range: Range of input function: See appropriate function section.
 F_{ext} : (External Oscillator Input) 100Hz-10MHz

Mode: Any input function

Accuracy: Accuracy of selected input function \pm trigger error of F_{ext} .

* ± 10 counts of input frequency. (± 1 count displayed)

** For any wave shape, trigger error is less than

$$\pm \frac{0.0025}{\text{Signal Slope (V/\mu s)}} \mu\text{s}$$

*** Trigger error is less than $\pm 0.3\%$ of one period + periods averaged for signals with 40 dB or better signal-to-noise ratio and 100 mV rms amplitude.

General 5326/5327 Specifications

Display: 7 digits (8 optional)
Blanking: Suppresses display of unwanted zeros left of the most significant digit.
Display Storage: Holds reading between samples. Rear panel switch overrides storage.
Sample Rate: FAST position: Continuously variable from less than 100 μ s to approximately 20 ms. NORM position: Continuously variable from less than 20 ms to approximately 5 seconds. HOLD position: Display can be held indefinitely.
Overflow: Neon indicates when display range is exceeded.
Operating Temperature: 0° to 50°C (See DVM Temp Range).

Time Base

Crystal Frequency: 10 MHz

Stability:

Aging Rate: < 3 parts in 10^7 /mo.

Temperature: $\leq \pm 2.5$ parts in 10^6 , 0° to 50°C

Line Voltage: $\leq \pm 1$ part in 10^4 for 10% line voltage.

Oscillator Output: 10 MHz, TTL type output levels, 50 Ω series impedance at rear panel BNC.

External Input: 100 Hz-10 MHz; 1 V rms into 1 k Ω .

Time Base Output: Negative pulses, +3 V to 0 V (open circuit) typically 100 ns wide. In all functions except START, TIME INTERVAL AVERAGE, and PERIOD AVERAGE, output is 10 MHz divided by TIME BASE/MULTIPLIER switch setting. Available at rear panel BNC.

Gate Output: TTL level pulses; low while gate open, high while gate closed. Available at rear panel BNC.

Power Requirements: 115 or 230 volts $\pm 10\%$, 50 to 60 Hz, 70 watts maximum.

Weight:

5326A: Net 15 lb 9 oz. (7.1 kg), Shipping, 18 lb 7 oz. (8.4 kg).

5326B: Net, 16 lb (7.3 kg), Shipping, 18 lb 14 oz. (8.6 kg).

5326C: Net, 15 lb 3 oz. (6.9 kg), Shipping 18 lb 1 oz. (8.5 kg).

5327A: Net, 15 lb 11 oz. (7.2 kg), Shipping 18 lb 9 oz. (8.4 kg).

5327C: Net, 15 lb 7 oz. (7.0 kg), Shipping 18 lb 5 oz. (8.3 kg).

Dimensions: 3 15/32" high x 16 3/4" wide x 11 1/4" deep (88 x 425 x 286 mm).

Accessories Furnished: Power cord, 7 1/2 ft. rack mount kit

Price: 5326A: \$1,195.00

5326B: \$1,550.00

5326C: \$950.00

5327A: \$1,795.00

5327C: \$1,550.00

Accessories Available:

HP 10503A, 50 Ω BNC Cable, 4 ft (122 cm). Price \$7.00.

HP 10532A, Extender Board Kit containing 2 ea. 15-pin extender 5060-0049, 1 ea. 18-pin extender 5060-2041, and 1 ea. Amplifier Extender. 10532-60001. Price \$50.00.

HP 10542A, Remote Programming Interface enables interfacing

between the 5326/5327 Series counters with Option 004 and a 40-bit Output Register. Includes two (2) 7 Bit Digital-to-Analog Converters for level controls and decoding for time base and function selector.

HP Cable 562A-16C (6 ft. 183 cm) to connect 5326/5327 Series with Option 003 to HP 5050B or 5055A Digital Recorder. Price \$50.00.

Option 001: 8-digit display. Price: \$75.00.

Option 002: Remote programming.

Controls: All front panel controls are single line programmable except:

Sep-Com (separate-common) switch; the check function is programmable (5326A/B, 5327A only).

Fast/Norm Mode.

Input Attenuators.

AC/DC Input Signal Coupling.

Control Signal: Single line control using either contact closure to ground or DTL drive on all lines except trigger levels which are analog programmed. (± 3 V dc).

Connector: Rear panel connector: HP 1251-0085; Amphenol 57-40360-375; (36-pin blue ribbon)

Mating connector: HP 1251-0084; Amphenol 57-30360-375.

Price: \$75.00.

Option 003: Digital output (for numerals and polarity only).

Code: 4-line 1-2-4-8 BCD "1" state high "0" state +0.25 V at -1 mA; "1" state: +5 V open circuit, 2.5 k Ω source impedance, nominal.

Print Command: +5 V to 0 V, dc coupled; occurs at end of gate.

Storage: Buffer storage is provided so BCD output is constant while next measurement is being made.

Inhibit Input: Inhibits gate when instrument's cycle time is less than the time required for external equipment to interrogate BCD outputs. Positive inhibit +5 V dc.

Connector: Rear panel connector: HP 1251-0087; Amphenol 57-40500-375; (50-pin blue ribbon)

Mating Connector: HP 1251-0086; Amphenol 57-40500-375.

Price: \$50.00.

Option 004: Remote Programming including all signal input conditions.

Controls: All front panel controls are programmable except:

Fast/Norm Mode

Control Signal: Single line control using either contact closure to ground or DTL drive on all lines except trigger levels which are analog programmed (± 3 V dc)

Connector: Rear panel connector: HP 1251-0087; Amphenol 57-40500-375; (50-pin blue ribbon)

Mating Connector: HP 1251-0086; Amphenol 57-30500-375.

COUNTERS & FREQ/TIME STANDARDS



SYSTEMS PROGRAMMER

Automatic measurement/computation/control
Model 5376A

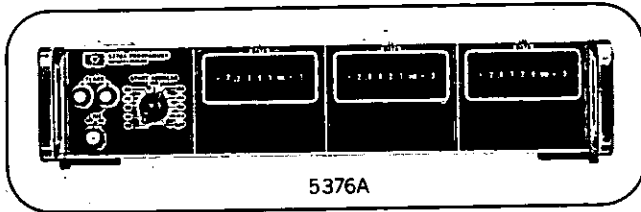

Converts 5360A Computing Counter Into an Automatic Computing/Measuring System With:

- Simple programming
- Precision system measurement capability
- ROM program (easily reprogrammed)
- Digital I/O capability
- Programmable analog output
- Options maximize price/performance
- For systems, production, laboratory, maintenance, and test

With the 5376A Systems Programmer, the HP 5360A Computing Counter System (request 5360A data sheet) provides economical, ready-to-use solutions to problems that formerly required the use of a computerized instrumentation system. The associated 5360A Computing Counter not only measures time interval and frequency faster and more accurately than other counters but also solves equations whose variables are the counter's measurements. The 5376A programs the computation, accepts digital data from other sources (digital voltmeters, etc.) for arithmetic processing and provides analog voltage outputs for data plotters or as a feedback signal in closed loop control systems. Three equation constants can be entered in optional thumbwheel switches. The 5360A/5376A combination finds wide use in the general areas of data reduction, statistical analysis and process control.

Programming

For dedicated applications in production, systems, equipment maintenance and check out, programming can be achieved by inserting diodes in appropriate coordinates of a matrix. The instrument is provided with a 40 step program capacity which can be optionally expanded to 200 steps.

For the laboratory environment or where the 5360A/5376A is intended for a number of applications, an alternative programming method using a punched card reader is available. Each card provides a 160 step program capacity.

A versatile program statement set is provided with the 5376A, viz:

1. Data Entry: e.g. Computing Counter measurements, external instrument measurements, manual.
2. Arithmetic: e.g. +, -, X, ÷, \sqrt{X} , X², X¹⁰, X^{1/10}. Sufficient memory exists for algorithms of more complex arithmetic functions to be inserted, e.g. log, x, e^x, sin x, etc.
3. Register Transfer & Storage for data manipulation and storage.
4. Readout & General Control: e.g. display, system timing synchronization, etc.
5. Looping & Branching: e.g. conditional program branching, sub-routines, etc.

Analog Output

Up to two digital-analog converters can be installed in the 5376A. These can be used for plotting the results of a program, providing a programmable voltage stimulus to a device under test, or providing an analog feedback signal in a closed loop process control system.

Digital Input/Output

Parallel digital data can be outputted to the standard Hewlett-Packard 5050B or 5055A Digital Recorders to provide printed records of the results of programs.

Parallel digital data from external instruments can also be inputted to the 5376A. This enormously increases the power and versatility of the Computing Counter System since potentially every digital Hewlett-Packard instrument (with +8421 code) can be incorporated.

Operation

The 5376A is very simple to program and integrate into a practical working system. For full details refer to the 5376A Systems Programmer User's Manual. This is available on request. Once programmed and integrated into a working system, the 5376A is easily operated and can be used by unskilled operators.

Options

The 5376A features eight separate options, any or all of which can be installed in the instrument. This option mix maximizes price/performance ratio; just purchase those options required to meet your specific requirements. All options may be installed in the field. This allows easy updating of the 5376A to additional applications.

5380 Integrated Systems

Occasions will arise where it is more convenient for Hewlett-Packard to provide the software and integrate the complete system for a specific application.

The 5380A systems include the 5360A Computing Counter, the 5376A Systems Programmer and other peripheral instruments necessary to meet the written specifications provided. Prices vary depending on the system complexity and the amount of hardware involved.

Options

- Option 001** Initial Thumbwheel Switch Assembly, \$275
For manual entry of numerical data
- Option 002** Additional Thumbwheel Switch Assemblies, \$150 ea.
Up to two additional assemblies can be installed.
- Option 003** Program Board, \$350 ea.
40 program steps per board. One board is provided with the instrument and up to four additional boards can be installed.
- Option 004** Program Diodes, \$65
Provides 22 additional program diodes.
- Option 005** Register Card, \$200 ea.
Each board contains two storage registers.
Up to three register cards can be installed.
- Option 006** Digital-Analog Converter, \$500 ea.
Up to two digital-analog converters can be installed
- Option 007** Parallel Digital Input/Output, \$600
- Option 008** Card Reader, \$2090

5376A Systems Programmer

Operating Temperature: 0°C to +50°C

Power: 115V or 230V ±10%, 50 to 400 Hz, 70W with all options included

Dimensions: 16 3/4" wide, 3 15/32" high, 16 3/8" deep

Weight: Net 21 lbs, shipping 25 lb 10 oz

Price: \$1350 (includes one 40 step program board)

QUARTZ THERMOMETER

0.0001°C or °F resolution, direct measurement
Model 2801A



TEMPERATURE

The method of temperature sensing employed in the 2801A Quartz Thermometers is based on the sensitivity of the resonant frequency of a quartz crystal to temperature change.

Temperature range of the 2801A Quartz Thermometer is -80 to $+250^{\circ}\text{C}$ (-112 to $+482^{\circ}\text{F}$). The quartz thermometer is considerably more linear than a platinum resistance thermometer: $\pm .05\%$ of span from -40 to $+250^{\circ}\text{C}$ compared with a typical figure of $\pm .55\%$ for the same range for platinum thermometers. Linearity of the quartz thermometer is superior to that of thermocouples and thermistors, which have an exponential characteristic. The excellent sensing characteristics of the quartz thermometer are supplemented by the advantages of direct digital readout (no bridge balancing, or reference to resistance or voltage-temperature tables or curves), immunity to noise and cable resistance effects, no reference junction, and good interchangeability between sensing probes.

The 2801A is equipped with two sensing probes for measuring temperature at either probe or the difference between the two. A 6-digit visual readout and recording output with a choice of pushbutton-controlled sample times provides resolution of 0.01, 0.001 or 0.0001°C or F. With Option M40 (100 second sample period) resolutions of 0.001, 0.001 or 0.00001°C or °F can be obtained. Signal polarity indication is provided. The 2801A includes the capability for operation as a 300 kHz electronic counter.

Temperature sensing probes

Various standard probe configurations are available for the 2801A Quartz Thermometer. Probes from the 2850 series are furnished with the quartz thermometer. Outline drawings for all models appear at right.

Remote operation of probes

Each temperature sensing probe has a quartz-crystal which is resonant at a frequency dependent upon temperature, and is driven by a 2830A Sensor Oscillator. The oscillators are transistorized devices enclosed in small die-cast aluminum housings. They are normally installed in the 2801A flush-mounted in a front panel recess. 12-foot cable connects each probe to its associated sensor probe; this cable forms part of the tuned circuit and cannot be altered in length. However, the sensor oscillators may be unplugged from the instrument and connected to it by standard 75-ohm coaxial cable up to 500 feet in length, with no loss in measurement accuracy. For greater distances, one or two 2831A Amplifiers may be used for a maximum of 4500 feet.

Specifications 2801A

Temperature range: -80 to $+250^{\circ}\text{C}$ (-112 to $+482^{\circ}\text{F}$ with Option M1).

Calibration accuracy: thermometer-probe combination calibrated at factory to within $.02^{\circ}\text{C}$ ($.04^{\circ}\text{F}$) absolute, traceable to NBS.

Linearity: -40 to $+250^{\circ}\text{C}$: Better than $.15^{\circ}\text{C}$ ($.27^{\circ}\text{F}$) referred to best fit straight line through 0°C ; -80 to -40°C : Better than 0.7°C (1.25°F) referred to same line as above; 0 to $+100^{\circ}\text{C}$: Better than $.05^{\circ}\text{C}$ ($.09^{\circ}\text{F}$) referred to best fit straight line through 0°C .

Stability:

Short term: better than $\pm .0001^{\circ}$.

Long term: zero drift less than $\pm .01^{\circ}\text{C}$ ($.018^{\circ}\text{F}$) at constant probe temperature for 30 days.

Ambient temperature effect: less than $.002^{\circ}\text{C}$ per $^{\circ}\text{C}$ change.

Display: 2801A: 6-digit in-line readout in $^{\circ}\text{C}$, or $^{\circ}\text{F}$. Decimal point, $^{\circ}\text{C}$ ($^{\circ}\text{F}$), and polarity indication included. Readout and units indication in kc in counter mode of operation. Storage feature holds display between readings.

Digital recorder output: BCD, 4-2'-2-1, positive-true, for each digit, decimal point (exponent), polarity, and operating mode. 8-4-2-1 positive true optionally available.

External programming: selected by contact closures or transistor circuit closures to ground. Measurement initiation, probe selection

(T1, T2, or T1-T2), and resolution (.01, .001, or .0001°) programmable.

Counter operation: Frequency Range: 2 Hz to 300 kHz; Resolution: 10, 1, and 0.1 Hz; Sensitivity: 0.5 to 10 V rms; Input Impedance: 1M, 50 pF shunt; Gate Time: 0.1, 1 and 10 sec.

Power required: 115/230 V $\pm 10\%$, 50 to 60 Hz, 85 W.

Instrument environment: ambient temperatures from 0 to $+55^{\circ}\text{C}$ ($+32$ to $+130^{\circ}\text{F}$), at relative humidity to 95% at 40°C .

Weight: net 22.5 lb (10.1 kg), shipping 35 lb (15.9 kg).

Dimensions: 3-15/32" x 16-5/16" x 16-3/4" (88 x 414 x 425 mm).

Price: 2801A Quartz Thermometer, including two 2830A Sensor Oscillators and two (matched) 2850 series Temperature Sensors, \$3,250.

HP-2831A Amplifier Specifications

Operating frequency: 28 to 29 MHz approx.

Gain: 40 dB approx.

Power required: +12 to +20 V dc, at 8 mA approx. (Normally supplied by HP 2801A.)

Connectors: coaxial output connector mates with HP 2801A Quartz Thermometer.

Operating conditions: same as HP 2830A Sensor Oscillator.

Dimensions, weight, finish: same as HP 2830A Sensor Oscillator.

Price: 2831A Amplifier, \$100.

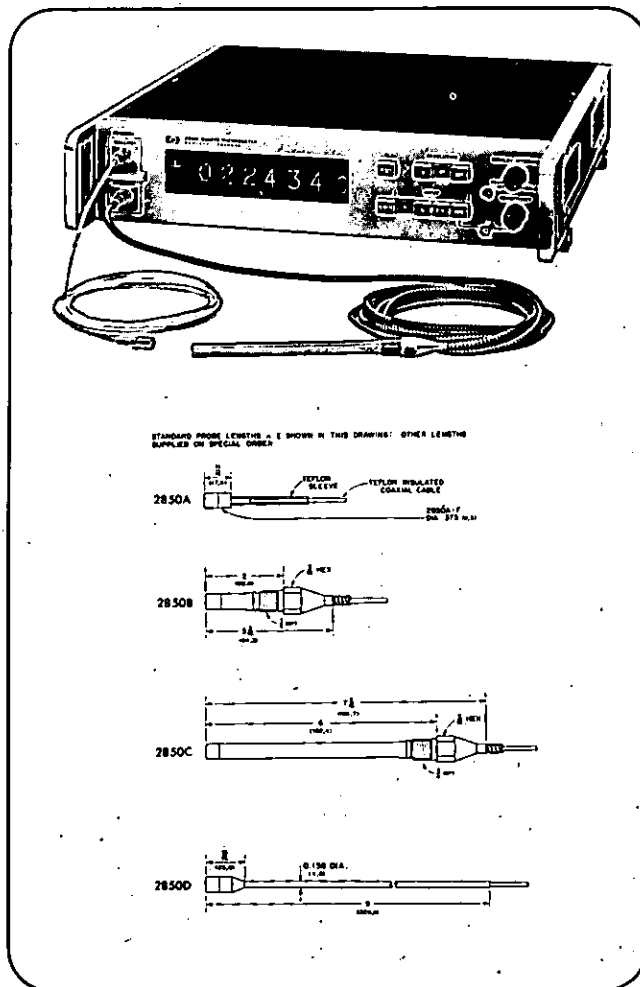

HEWLETT  PACKARD